

LDC50: 50Hz Line Droop Compensator

The LCD is a line drop compensator for MeccAlte 50Hz series. It allows to compensate, interacting with the generator AVR, the voltage droop caused from the distribution line as a function of the load current.

Description, installation and mechanical dimensions

The LDC50 system has to be installed inside the generator terminal box. The system is composed of two parts:

- Current transformer LDCT
- Electronic module LDCM50

Current transformer LDCT

The current transformer named LDCT, is designed to be assembled in the terminal board saddle of any MeccAlte 50Hz generator by means of 4 bolts M4x16; the mechanical dimensions and the fixing holes are described in fig. 1 while the technical specs are described in tab. 1.

The number of cables per phase that has to pass through the LDCT are described tab. 2: this value is changing respectively the generator size.

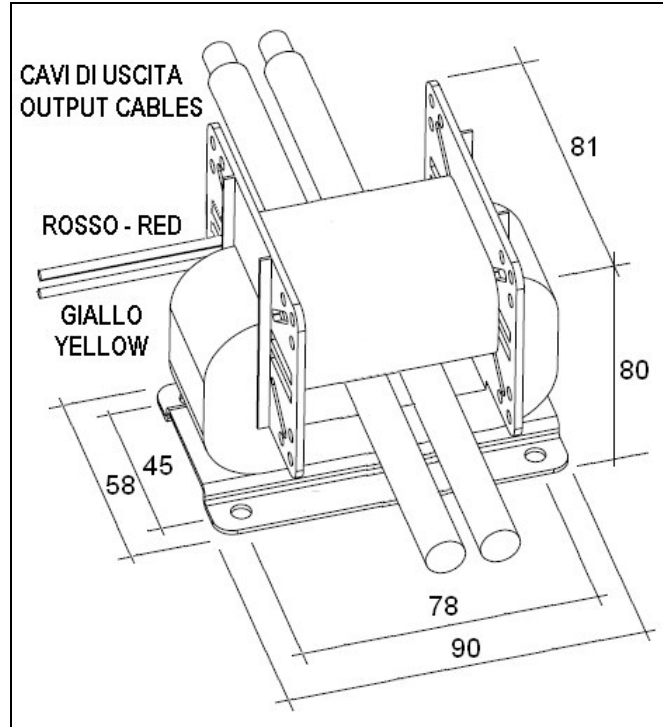

Fig. 1: Current Transformer LDCT

Electronic module LDCM50

The electronic module LDCM50 has to be assembled close to the voltage regulator by means of two bolts M4x20; mechanical dimensions and terminal numbers are indicated in fig. 2 while the technical specs are described in tab. 3.

The LDCM50 module has got a 7 pin male faston terminal, used for all the connection between the unit, the AVR and the sensing current transformer LDCT. The cabling scheme is designed not to interfere with the existing cabling scheme of the AVR, if the LDC50 has to be retrofitted: for this reason no AVR disconnection is necessary. All the connection, female fastons and terminal are not in the scope of supply of the LDC50 unit. Cables with a minimum 0,5mm² section are recommended.

Figures. 3 e 4 describe the connection schemes with ECO38 generator series.

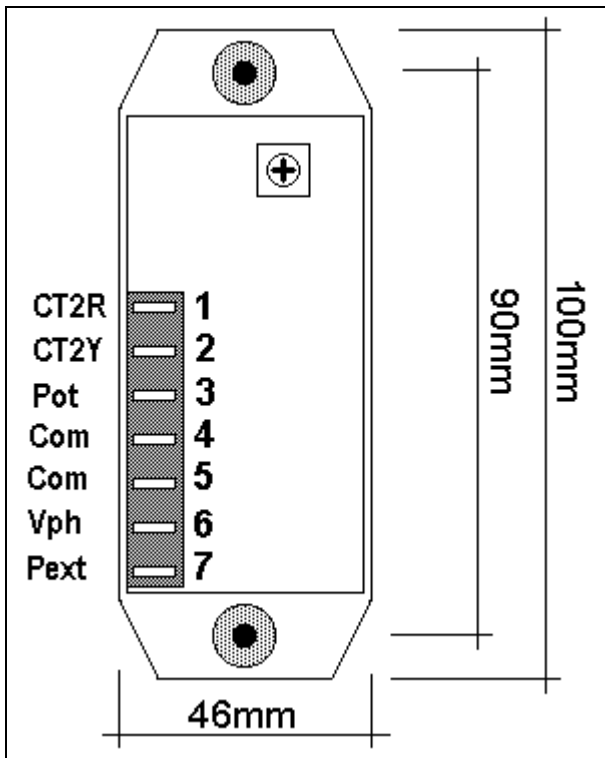

Fig. 2: Electronic Module LDCM50

The LDCM50 module has got in board a potentiometer necessary for the impedance compensation calibration, which is a function of the characteristic of the distribution line and can not be pre determined.

Tab. 1: LDCT Technical Specifications

LDCT - LINE DROOP CURRENT TRANSFORMER	
Weight	1,05 Kg
Maximum measurement current	650 Arms
Secondary winding resistance	17,5 Ohm

Tab. 2: LDCT Cabling

Alternator	Pn [KVA]	In(@Vo=200V) [A]	Cables per phase	N° of turns
ECO38-1SN/4	180	260	1	2
ECO38-2SN/4	200	288	1	2
ECO38-3SN/4	225	325	1	1
ECO38-1LN/4	250	360	1	1
ECO38-2LN/4	300	433	1	1
ECO38-3LN/4	350	505	1	1

Tab. 3: LDCM50 Input and Output list

LDCM50 – 50Hz LINE DROOP COMPENSATOR MODULE				Connections		
Terminal	Description	Function	Specification	Device	Terminal	Function
1	CT2R	LDCT Input	0 ÷ 500mA	T.A. LDCT	Red	Generator Current measurement
2	CT2Y		50Hz	T.A. LDCT	Yellow	
3	Pot	External pot. input	100K	External Pot.	Cursor	(Optional) Voltage fine tuning
4	Com	Common		External Pot.	Lateral	
5	Com	LDCM50 - AVR		SR7/2G	5B	Neutral reference
6	Vph	Power supply	80÷150V - 50Hz	SR7/2G	4A	Phase reference
7	Pext	Exit	2 ÷ 15Vdc	SR7/2G	7	External potentiometer

Set up

Preliminary Operations

NOTE: All the connection between the LDCM50, the LDCT, the alternator AVR and the remote potentiometer have to be accomplished while the generator is not running and disconnected from any power source.

Follow the cabling scheme for the appropriate connection (either fig. 3 for the SR7/2G or fig. 4 for UVR6/1F with single phase reference).

IMPORTANT: Before to start up the unit, turn fully counter-clockwise the potentiometer on board of the LDCM50!

Start up the gen set at the nominal speed

Check the voltage and the frequency, that should be at the nominal conditions (400V / 50Hz in standard machines).

LDCM50 Setting

Connect the nominal load to the generator, that should be powered supply by means of a similar or equal distribution line of the final application..

Check the voltage output at the end of the distribution line: should be lower than nominal. Set this voltage to the nominal generator value slowly turning the potentiometer on board of the LDCM50, continuously checking the voltage at the end of the line: this operation set the compensation point that assure a linear voltage compensation as a function of the line current.

The generator is now compensated by a value equal to the voltage drop present in the distribution line, in any load condition. Please check that the voltage output at the generator terminal does not exceed 110% of the nominal voltage when nominal load is applied. Remove the load, and check that the generator output voltage is back to the nominal value or that at the end of the distribution line the voltage is constant respectively of the full load condition.

External Potentiometer

When a 100Kohm linear potentiometer is connected between terminals 3 and 4 of the LDCM50 module, an external voltage control is possible. Voltage control is on $\pm 8\%$ over the reference settled on the VOLT potentiometer of the AVR.

NOTE: when the potentiometer is connected, the system will sit down to a lower voltage output. For this reason it is mandatory to:

- Set up the regulator VOLT trimmer to recover the nominal voltage.
- In case of connection interruption of the external potentiometer, note that the voltage will be higher than the nominal also in no load condition.
- If the external potentiometer is removed, the VOLT trimmer has to be settled again to recover the nominal voltage.

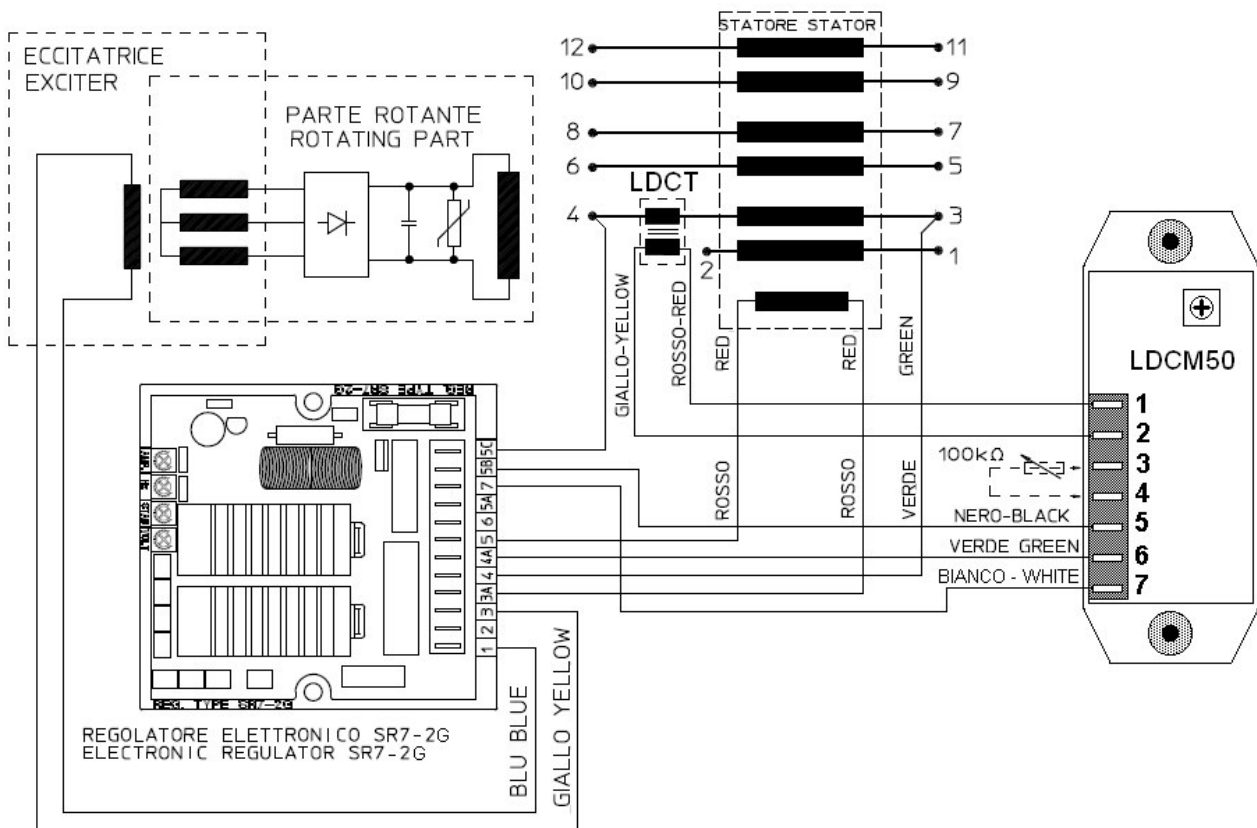

Fig. 3: LDC50 system cabling on an ECO38 generator equipped with the SR7/2GB regulator.

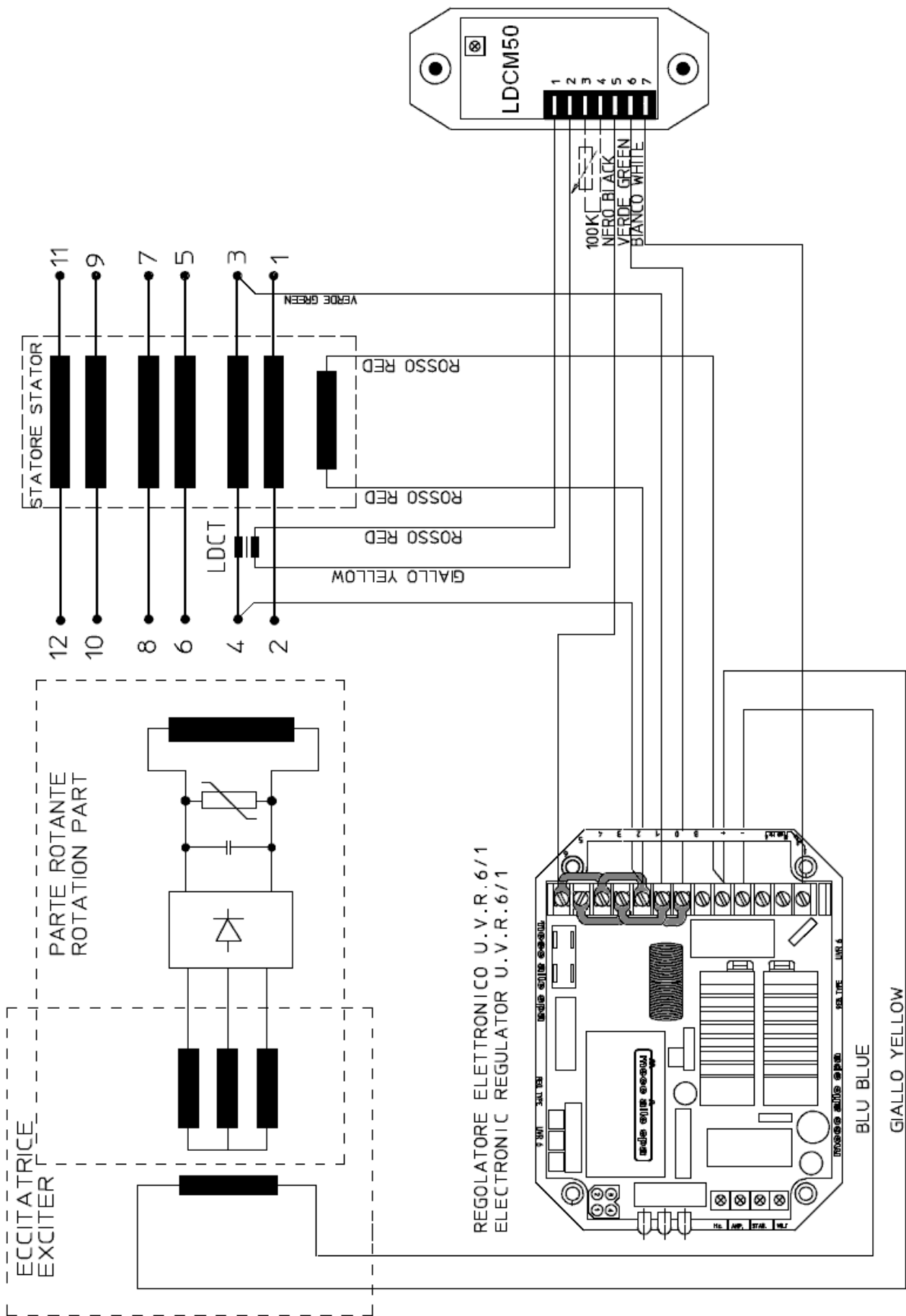

Fig. 4: LDC50 system cabling on an ECO38 generator equipped with the UVR6/1F regulator.