



SMARTeCH<sup>3</sup>

POWER FROM WITHIN

# GC600/MC200 Neptune CONTROLLER

TECHNICAL MANUAL





## Table of Contents

<b>1</b>	<b>Introduction .....</b>	<b>5</b>
<b>2</b>	<b>Power supply (JC) .....</b>	<b>5</b>
<b>3</b>	<b>Digital static output (JR-JQ) .....</b>	<b>6</b>
<b>4</b>	<b>Auxiliary Analogic Input (JU) .....</b>	<b>7</b>
<b>5</b>	<b>USB Communication interface (JNA-JNB) .....</b>	<b>7</b>
<b>6</b>	<b>Serial port 1 RS232 (JA) .....</b>	<b>7</b>
<b>7</b>	<b>Serial port 2 RS485 (JW) .....</b>	<b>8</b>
<b>8</b>	<b>Ethernet port (JY) .....</b>	<b>8</b>
<b>9</b>	<b>CAN-BUS communication port (JM) .....</b>	<b>8</b>
<b>10</b>	<b>CAN-BUS communication port (JX) .....</b>	<b>8</b>
<b>11</b>	<b>Analogue output 1 (JT) .....</b>	<b>9</b>
<b>12</b>	<b>Analogue output 2 (JS) .....</b>	<b>9</b>
<b>13</b>	<b>Views of the device .....</b>	<b>10</b>
<b>14</b>	<b>Technical features .....</b>	<b>11</b>
14.1	Measurement resolution .....	19
<b>15</b>	<b>Wirings to comply with marine certification .....</b>	<b>20</b>
15.1	MCB circuit breaker feedback .....	20
15.2	MGCB circuit breaker feedback .....	21
15.3	GCB circuit breaker feedback .....	21
15.4	GCB circuit breakers feedback to MC200 .....	22
15.5	“Dead bus” secondary check .....	22
15.6	GCB closure electrical interlocks .....	23
15.7	Speed command for synchronization .....	24
15.8	Start command .....	25
15.9	Quay’s voltage presence .....	26

# 1 Introduction

This document contains additional information and notes for the GC600 Neptune and MC200 Neptune devices. For all the rest, please refer to the technical manuals of the MC200 and GC600 controllers:

- EAAM052213EN Technical Manual GC600-GC600Mains
- EAAM058707EN Technical Manual MC200

The purpose of this document is to explain notes/condition from our Marine certificates and to show the recommended solution. The manual contains recommendations and conditions which were mentioned by the certification engineer during the certification process. It is necessary to comply all rules of a relevant Marine certification.

Controller is tested and approved for:

- Placement in Machinery spaces and control room.
- According to EMC rules for general power distribution zones.

# 2 Power supply (JC)

The nominal power supply of the controller is 12Vdc or 24Vdc: It can work with both 12V and 24V battery systems. It's able to survive 0 V for 20 mS providing the supply was at least 12 V before the dropout and recovers to 5 V afterwards. In case a longer survival time is required, it is necessary to add externally diode and capacitor according to the following scheme.

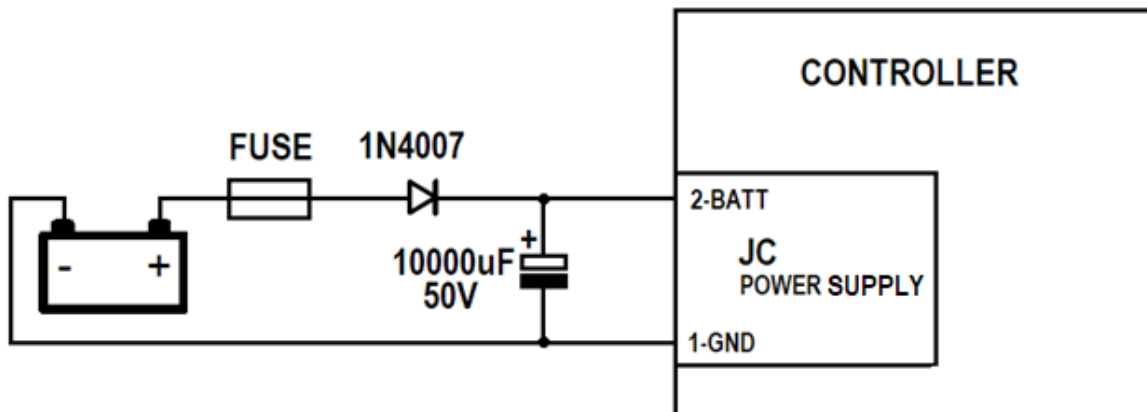

The controllers contain overvoltage protection on the power supply terminals for increased endurance against surges and interference:  $\pm 2\text{kV}$  (from positive battery to earth) and  $\pm 1\text{kV}$  (from positive to negative battery). External fuse rated max. 2.5A shall be used to limit current from the power supply to the controller. Controller should never be connected directly to the starting battery. Recommended fuse (not fast) type (one to internal capacitor charging during power up).

### 3 Digital static output (JR-JQ)

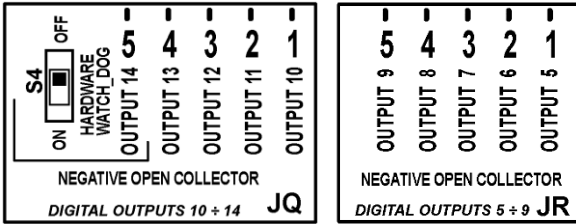

The maximum cable length for the binary outputs of the JR and JQ connectors must be less than 10 meters. If a longer length is required, the outputs must be relaunched with auxiliary relays according to the following scheme. Do not connect binary outputs directly to DC relays without protection diodes. Use protection diodes even if the relays are not connected directly to controller outputs. Use a fast recovery 3A / 50V diodes. External fuse rated max. 2.5A shall be used to limit current from the binary outputs.

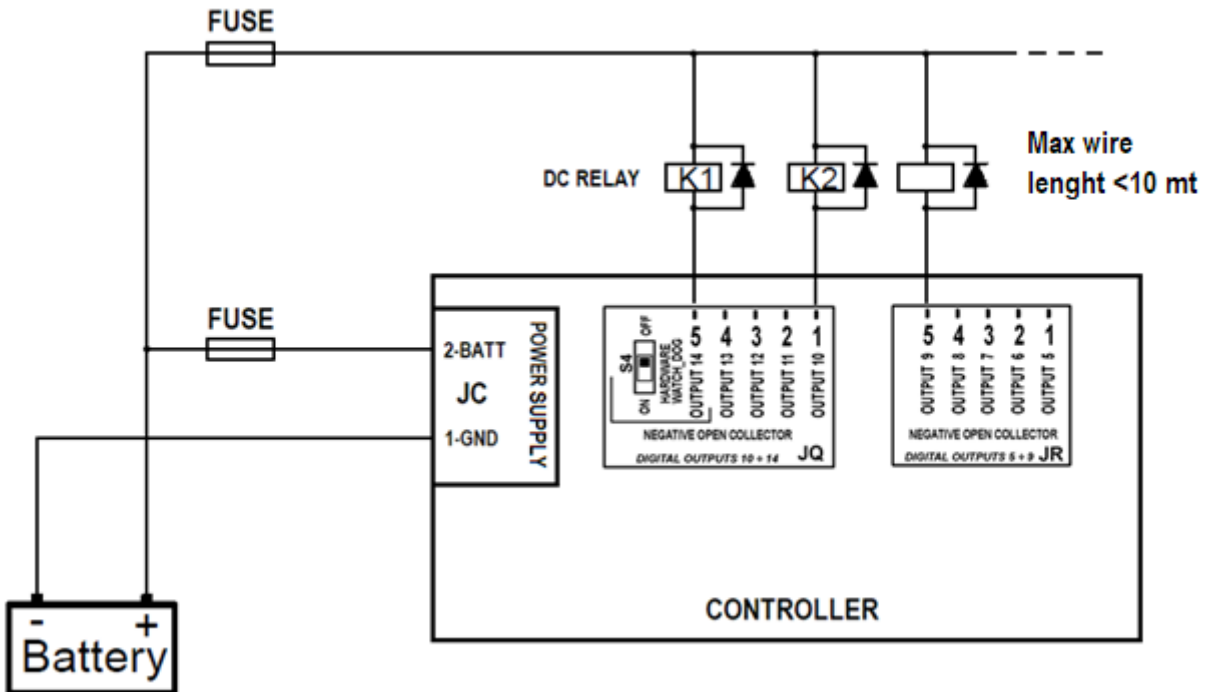

Alternatively, overvoltage protection must be added.



## 4 Auxiliary Analogic Input (JU)

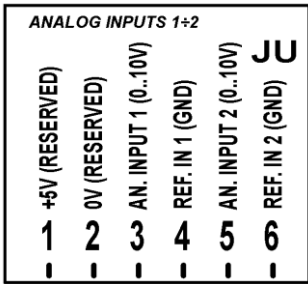

For the connection of this analogue input port, it is necessary to use shielded cables with shield connected to ground on one side only (controller side).

## 5 USB Communication interface (JNA-JNB)

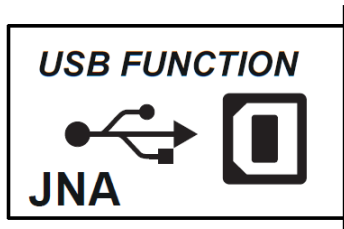

The USB protocol specifications doesn't allow its use in permanent industrial field due to the limited length of the cable and of the elevated sensibility to electric disturbs also on PC side. For this reason, the USB connection cable must be inserted only when necessary to operate on the device and can be removed from the connector when the operation has finished. The maximum cable length for the JNA and JNB connectors must be less than 3 meters.

## 6 Serial port 1 RS232 (JA)

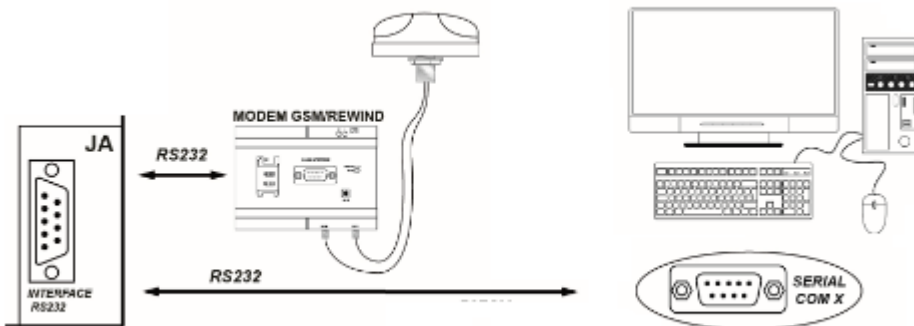

It's a RS232 serial port with DB9 male connector usable for the interfacing with an external device equipped with RS232 interface. The maximum length of the cable must be less than 10 meters. For the connection of this serial port, it is necessary to use shielded cables with shield always earthed at only one end (controller side).

## 7 Serial port 2 RS485 (JW)

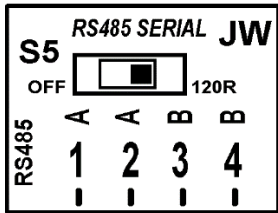

It's RS485 serial port with galvanic insulation; the maximum connection length in optimal conditions is 1200 mt. The 120ohm terminal resistor is integrated and can be inserted through S5 selector. The use of a shielded cable with 120ohm impedance is required (e.g., BELDEN 3105A Multi-conductor-EIA Industrial RS-485PLT/CM). For the connection of this serial port, it is necessary to use shielded cables with shield always earthed at only one end (controller side).

## 8 Ethernet port (JY)

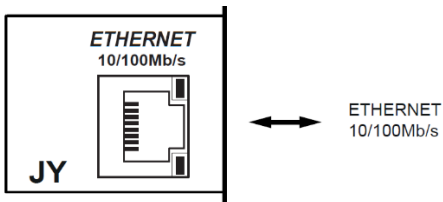

For the connection of this serial port, it is necessary to use special shielded cables with shield always earthed at only one end (Hub/switch side). The maximum length of the cable must be less than 100 meters.

## 9 CAN-BUS communication port (JM)

GC600

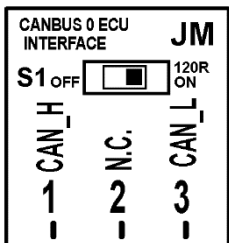

MC200

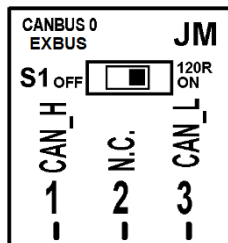

A CAN-BUS port with galvanic insulation for the communication with ECU engine. The 120ohm terminal resistor is integrated and can be inserted through S1 selector. The specific use of the shielded cable is required (e.g., HELUKABEL 800571). For the connection of this port, it is necessary to use shielded cables with shield always earthed at only one end (controller side).

## 10 CAN-BUS communication port (JX)

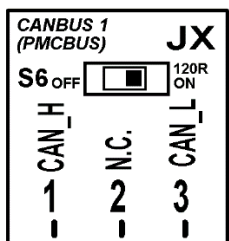

A CAN-BUS port with galvanic insulation for the communication with other devices of genset control and/or additional optional modules (DITEL, DITHERM, DIGRIN e DIVIT). The 120ohm terminal resistor is integrated and can be inserted through S6 selector.



The specific use of the shielded cable is required (e.g., HELUKABEL 800571). For the connection of this port, it is necessary to use shielded cables with shield always earthed at only one end (controller side).

## 11 Analogue output 1 (JT)

GC600

MC200

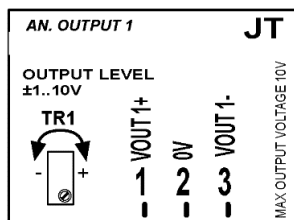
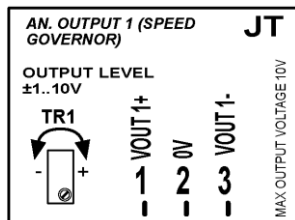

For the connection of this port, it is necessary to use shielded cables with shield always earthed at only one end (controller side).

## 12 Analogue output 2 (JS)

GC600

MC200

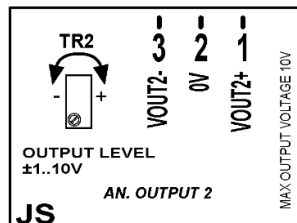
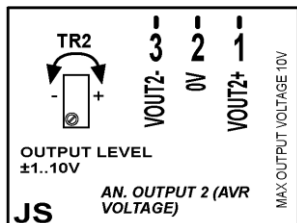

For the connection of this port, it is necessary to use shielded cables with shield always earthed at only one end (controller side).

## 13 Views of the device

GC600Neptune front view



MC200Neptune Front view



## 14 Technical features



**INFORMATION!** GND is referred to the potential of the terminal JC-1

Supply power voltage +VBATT:	
Nominal power supply (Vn)	12Vdc or 24 Vdc
Power supply range (Vn variation)	From 8 to 32Vdc The device identifies the plant operation at 12 or 24V to manage its alarms when powered up and whenever OFF/RESET mode is selected. Protection against polarity reversal with built-in self-resetting fuse. Resolution of the measurement of the battery voltage to 12 bits.
Starting minimum voltage	0 Vdc for min. 20 ms when coming from at least 12 V DC (cranking dropout)
Power consumption in stand-by:	Display minimum brightness: 350mA@ 13.5 Vdc 200mA @ 27 Vdc  Display maximum brightness: 420mA @ 13.5 Vdc 225mA @ 27 Vdc
Maximum power consumption during operation (relays, horn, digital inputs activated; static outputs not activated)	Display minimum brightness: Max. 670mA @ 7 Vdc 375mA @ 13.5 Vdc 235mA @ 27 Vdc  Display maximum brightness: Max. 810mA @ 7 Vdc 440mA @ 13.5 Vdc 260mA @ 27 Vdc
Mains/Bus and Genset voltage inputs	
	Measurement of the L-N and L-L phases voltages Measurements of the neutral voltages referred to the device supply negative External fuse max. 2A slow blow
Nominal Voltage (Vn)	100Vac / 400Vac
Scale	100V (LV - Low Voltage range) 400V (HV - High Voltage range) Selectable from the device parameter
Sampling rate	10Khz
Type of measurement	True RMS measurements (TRMS).
Input impedance	> 0,8 MΩ L-N > 1,3 MΩ L-N > 0.8 MΩ L-GND > 0.5 MΩ N-GND

Maximum voltages applicable	MAX 300Vac in CAT. IV for measurements L-N MAX 520Vac in CAT. IV for measurements L-L MAX 600Vac in CAT. III for measurements L-L
Maximum voltages measurable with scale HV	Max 448 Vac for measures L-N (with voltage N-GND = 0 Vrms)
Maximum voltages measurable with scale LV	Max 147 Vac for measures L-N (with voltage N-GND = 0 Vrms)
Max tension in Common-Mode from GND with HV scale	Max 100 Vrms
Max tension in Common-Mode from GND with LV scale	Max 80 Vrms
Connection mode	3 phases 4 cables 3 phases 3 cables Single phase 2 cables Aron insertion with 2 voltage transformers
Measurement resolution	12 bits
Measurement accuracy	<0,5% F.S.
<b>Current measurement inputs</b>	
	3 inputs with internal CT and common CTs ratio 1 independent auxiliary current with internal CT that can be used as current measurement for Neutral, differential protection or mains power. It is required the use of current transformers with a secondary current from 1A to 5A.  <b>The external TA must guarantee at least one BASIC isolation for the use of the device in the Overvoltage Cat. IV.</b>
Nominal Current (In)	1Aac or 5Aac
Scale	1Aac nominal (Low Current range) 5Aac nominal (High Current range) Internal amplifier with automatic change of scale for currents lower than 1,2Aac and higher than 1,5Aac.
Sampling rate	10 KHz
Measurement range	Up to 7Aac
Type of measurement	True RMS measurements (TRMS).
Auto-consumption	< 1VA
Overload capacity:	+40% of the nominal current Possible sinusoidal transient voltage surges up to 20 Aac with progressive loss of the measurement accuracy depending on the amplitude of the surge.
Measurement resolution	12 bits
Measurement accuracy	<0,2% F.S.
<b>Frequency measurements</b>	
	Frequencies measured by L1-L2 phase voltages, for both the mains/bus and the genset. In case of single-phase systems, the detection of the frequency is carried out on the L1 voltage with respect to N (connected in place of L2).
Nominal Frequency (Fn)	50Hz or 60Hz



Measurement range	5 to 80 Hz																		
Measurement accuracy	± 50 mHz																		
Frequency minimum sensitivity for Mains/bus voltage input	<table border="1"> <thead> <tr> <th><i>Rated voltage 100Vac</i></th> <th><i>Rated voltage 400Vac</i></th> </tr> </thead> <tbody> <tr> <td>8 Vrms L1-N @ 50Hz</td> <td>24 Vrms L1-N @ 50Hz</td> </tr> <tr> <td>14 Vrms L1-L2 @ 50Hz</td> <td>41 Vrms L1-L2 @ 50Hz</td> </tr> <tr> <td></td> <td></td> </tr> <tr> <td>8 Vrms L1-N @ 60Hz</td> <td>8 Vrms L1-N @ 60Hz</td> </tr> <tr> <td>16 Vrms L1-L2 @ 60Hz</td> <td>43 Vrms L1-L2 @ 60Hz</td> </tr> </tbody> </table>	<i>Rated voltage 100Vac</i>	<i>Rated voltage 400Vac</i>	8 Vrms L1-N @ 50Hz	24 Vrms L1-N @ 50Hz	14 Vrms L1-L2 @ 50Hz	41 Vrms L1-L2 @ 50Hz			8 Vrms L1-N @ 60Hz	8 Vrms L1-N @ 60Hz	16 Vrms L1-L2 @ 60Hz	43 Vrms L1-L2 @ 60Hz						
<i>Rated voltage 100Vac</i>	<i>Rated voltage 400Vac</i>																		
8 Vrms L1-N @ 50Hz	24 Vrms L1-N @ 50Hz																		
14 Vrms L1-L2 @ 50Hz	41 Vrms L1-L2 @ 50Hz																		
8 Vrms L1-N @ 60Hz	8 Vrms L1-N @ 60Hz																		
16 Vrms L1-L2 @ 60Hz	43 Vrms L1-L2 @ 60Hz																		
Frequency minimum sensitivity for Genset voltage input	<table border="1"> <thead> <tr> <th><i>Rated voltage 100Vac</i></th> <th><i>Rated voltage 400Vac</i></th> </tr> </thead> <tbody> <tr> <td>1 Vrms L1-N @ 10Hz</td> <td>1,2Vrms L1-N @ 10Hz</td> </tr> <tr> <td>1,7 Vrms L1-L2 @ 10Hz</td> <td>2 Vrms L1-L2 @ 10Hz</td> </tr> <tr> <td></td> <td></td> </tr> <tr> <td>5 Vrms L1-N @ 50Hz</td> <td>13 Vrms L1-N @ 50Hz</td> </tr> <tr> <td>9 Vrms L1-L2 @ 50Hz</td> <td>22 Vrms L1-L2 @ 50Hz</td> </tr> <tr> <td></td> <td></td> </tr> <tr> <td>6 Vrms L1-L2 @ 50Hz</td> <td>18 Vrms L1-N @ 60Hz</td> </tr> <tr> <td>10 Vrms L1-L2 @ 60Hz</td> <td>31 Vrms L1-L2 @ 60Hz</td> </tr> </tbody> </table> <p>The sensitivity decreases with the increase of the frequency for the acknowledgement of the engine running and for a higher rejection of the disturbances.</p>	<i>Rated voltage 100Vac</i>	<i>Rated voltage 400Vac</i>	1 Vrms L1-N @ 10Hz	1,2Vrms L1-N @ 10Hz	1,7 Vrms L1-L2 @ 10Hz	2 Vrms L1-L2 @ 10Hz			5 Vrms L1-N @ 50Hz	13 Vrms L1-N @ 50Hz	9 Vrms L1-L2 @ 50Hz	22 Vrms L1-L2 @ 50Hz			6 Vrms L1-L2 @ 50Hz	18 Vrms L1-N @ 60Hz	10 Vrms L1-L2 @ 60Hz	31 Vrms L1-L2 @ 60Hz
<i>Rated voltage 100Vac</i>	<i>Rated voltage 400Vac</i>																		
1 Vrms L1-N @ 10Hz	1,2Vrms L1-N @ 10Hz																		
1,7 Vrms L1-L2 @ 10Hz	2 Vrms L1-L2 @ 10Hz																		
5 Vrms L1-N @ 50Hz	13 Vrms L1-N @ 50Hz																		
9 Vrms L1-L2 @ 50Hz	22 Vrms L1-L2 @ 50Hz																		
6 Vrms L1-L2 @ 50Hz	18 Vrms L1-N @ 60Hz																		
10 Vrms L1-L2 @ 60Hz	31 Vrms L1-L2 @ 60Hz																		
Measurement resolution	0,1Hz ± 50ppm, 35ppm/C typical																		
<b>Digital inputs 01-08</b>																			
	8 opto-insulated digital inputs with same supply, internal supply terminal connected to the device positive JC (2) +Vbatt. They are active when the input is connected to the supply negative GND. When they are open, the inputs terminals voltage is like Vbatt.																		
Activation/deactivation threshold	2.5VDC																		
Typical current with closed contact	5,3mA @ +Vbatt= 13.5Vdc 11,5mA @ +Vbatt= 27Vdc																		
Input signal delay	It can be adjusted by the related parameter for each input																		
<b>Digital inputs 09-18</b>																			
	Further two groups of 5 opto-insulated inputs with two separated common supplies, which can be connected to GND (active inputs to +Vbatt) or to +Vbatt (active inputs to GND). Two selectors (S2 and S3) must be set to configure two groups of inputs as Common Plus or as Common Negative.																		
Activation/deactivation threshold	2,5VDC																		



Typical current with closed contact	5,3mA @ Vbatt= 13.5Vdc 11,5mA @ Vbatt= 27Vdc
Input signal delay	It can be adjusted by the related parameter for each input
<b>Digital outputs 01-04</b>	
Type of output	4 independent static outputs to battery positive. The output current is supplied by the positive supply terminal of the device JC (2) +Vbatt. All relay outputs are adjustable by parameter.
Rated supply	500mAdc @ 32Vdc for each output
Output resistor status ON	Max 350mΩ
“Leakage current” status OFF	Max 5uA@32Vdc
Protections	Internal current limited to about 4A max. on transients >150us Thermal protection, short circuit, overvoltage, and inverted polarity.  <b>Use external suppression diodes on all relays and other inductive loads</b>
<b>Digital outputs 05-13</b>	
Type of output	9 independent static outputs to battery negative. The output current is supplied by the negative supply terminal of the device JC (1) GND.  All relay outputs are adjustable by parameter.
Rated supply	Max. 280mAdc @ 32Vdc for each output Total maximum current for all activated outputs 2A @ 50°C.
Output resistor status ON	Max 500mΩ
“Leakage current” status OFF	Max 1uA@32Vdc
Protections	Internal current limited to 2,2A Typ. Thermal protection, short circuit, overvoltage with Auto Restart Inverted protection polarity.  <b>Use external suppression diodes on all relays and other inductive loads.</b>
<b>Digital outputs 14 - Output Hardware Watchdog</b>	
Type of output	1 static outputs to battery negative. The output current is supplied by the negative supply terminal of the device JC (1) GND. If it is enabled through the selector S4, the output can be used as output connected to a watch-dog system hardware-independent. If the watchdog is enabled (S4=ON) and the device works correctly, the output is running. If the device is blocked and/or does not refresh the watch-dog circuit for a time higher than 5 seconds, the output fails. If the device is turned off, the output immediately fails. If the watchdog is disabled (S4=OFF) the status of the output depends on its configuration.



Rated supply	Max. 280mA @ 32Vdc for each output Total maximum current for all activated outputs 2A @ 50°C.
Output resistor status ON	Max 500mΩ
“Leakage current” status OFF	Max 1uA@32Vdc
Protections	Internal current limited to 2,2A Typ. Thermal protection, short circuit, overvoltage with Auto Restart Inverted protection polarity.
<b>Digital outputs 15 and 16 - Engine commands</b>	
Type of output	2 relays with NO contacts and one positive common terminal. The positive common terminal has the function of input for the emergency stop. The measurement of the voltage on the common input is displayed at page S.15 of the display (EM-S). They can be used as starter motor (START) and fuel solenoid valve (FUEL).  All relay outputs are adjustable by parameter.
Rated supply	Max. 3A @ 30Vdc for each output
Protections	Self-restoring fuse and integrated opening power-surge protection diodes.
<b>Digital outputs 17 and 18 - Switch command</b>	
Type of output	2 relays with dry contacts for the contactors switch command All relay outputs are adjustable by parameter.
Rated supply	Max. 10A @250Vac.
<b>Output D+ and analogue input 07</b>	
Type of output	Current output with value automatically switched according to the supply voltage V <sub>batt</sub> . If it is not used for the excitation of the battery charger alternator, it is possible to configure the D+ terminal as analogue input to acquire voltage measurements from 0 to 32Vdc or as additional digital input with +V <sub>batt</sub> activation. The voltage measurement acquired is displayed in the page S.15 of the display.
Excitation current	200mA @ 13.5 Vdc 100mA @ 27 Vdc
Frequency	10kHz
Resolution	12 bits
<b>Analogue inputs 01-02</b>	
Type of input	2 differential analogue inputs 0...10Vdc Both inputs offer the possibility of differential measurement to compensate the differences of negative measurement with respect to GND. There's a 5Vdc (JU-1) regulated and protected output and an internal GND terminal (JU-2) that can be used as reference for external potentiometers on the two analogue inputs.
Measurement range	0 - 10Vdc
Compensation range	From -10Vdc to +6Vdc
Input impedance	> 470kΩ



Frequency	10kHz
Resolution	12 bits
Measurement accuracy	<0,4% F.S.
<b>Analogue inputs 03-06 and Vref</b>	
Type of input	4 adjustable analogue inputs, which can be used as engine equipment. Adjustable as resistive, voltage, current (with external resistor) and digital inputs. For the resistive sensors, there's an input for the measurement and compensation of the reference potential with respect to the sensor common negative (Vref).
Resistive inputs	Measurement range 0 – 500Ω with error < 0,2% 0 – 2kΩ with error < 1% Injected current: 25mA max. Compensation range (Vref): from -2,7Vdc to 6Vdc
Voltage inputs	Measurement range 0 – 10Vdc with error < 0,2% Input impedance: >470kΩ
Current inputs.	Measurement range 0 - 20mA with 500Ω external resistor
Frequency	10kHz
Resolution	12 bits
<b>Pick-up input for the measurement of the engine speed</b>	
	Filtered for DC currents blocking.
Minimum voltage	1,3Vac @ 3kHz
Maximum voltage	60Vac
Frequency range	1Hz – 10000Hz
<b>“W” inputs for the measurement of the engine speed</b>	
	It uses a pick-up input with internal anti-interference filter to insert by connecting the JM connector pin 7 and 8 to each other.
<b>Digital outputs 01-02</b>	
Type of output	2 galvanically insulated ±10Vdc voltage outputs They can be used for the AVR and engine speed analogue regulation. Each output has an integrated trimmer to reduce the maximum output voltage, preserving in this way signal resolution.
Regulation range	From -1Vdc to +10Vdc
Resolution	16 bits
Minimum load impedance	>10 kΩ
Insulation rated voltage	Max operating 560Vdc 3KVdc on transient < 60s.
Insulation resistor	>1000MΩ @ 500Vdc
<b>RS232 Communication interface</b>	
Type of interface	1 RS232 serial port standard TIA/EIA, not insulated on DB connector 9 poles male CANON
Electrical signals	TX. RX, DTR, DSR, RTS, GND



Settings	Baud rate selectable by parameter: 300, 600, 1200, 2400, 4800, <b>9600*</b> , 19200, 38400, 57600, 115200 bps Parity: <b>None*</b> , Even, Odd Stop bit: <b>1*</b> ,2 <b>* Default Setting</b>
Type of transmission	<b>Modbus RTU Slave*</b> , Modem AT <b>* Default Setting</b>
Maximum distance	Maximum cable length depends on cable capacitance, inductance, and screening. 10m (50ft) @ 9600bps 10m (33ft) @ 19200bps 7,5m (25ft) @ 38400bps 5,0m (16ft) @ 57600bps 2.5m (8ft) @ 115200bps
<b>RS485 Communication interface</b>	
Type of interface	1 RS485 serial port standard TIA/EIA, with galvanic insulation. Terminal resistor connectible with S5 switch.
Electrical signals	DATA+ (A), DATA- (B)
Settings	Baud rate selectable by parameter: 300, 600, 1200, 2400, 4800, <b>9600*</b> , 19200, 38400, 57600, 115200 bps Parity: <b>None*</b> , Even, Odd Stop bit: <b>1*</b> ,2 <b>* Default Setting</b>
Type of transmission	<b>Modbus RTU Slave*</b> , Modbus RTU Master (for connection to ECU CUMMINS) <b>* Default Setting</b>
Insulation voltage	Max operating 560Vdc 1KVdc on transient < 60s.
<b>USB 2.0 Communication interface</b>	
Type of interface	1 USB2.0 serial port not insulated, which can be used in Function or Host mode. Selection of the operating mode through SW5 dipswitch. <b>The USB port cannot be used as Function and Host simultaneously.</b>
Function Mode	Connection to PC by Sices Driver USB Connector type B. Type of transmission Modbus RTU Slave
Host Mode	Pen Driver Management USB Connector type A. Max current supplied 350mA@5Vdc with overcharge automatic protection. <b>Host function is not supported so far</b>
Maximum distance	6m (20 feet)
<b>CANBUS Communication interface</b>	
Type of interface	2 CANBUS serial ports with galvanic insulation. Terminal resistor connectible with S1 and S6 switch.



CanBus0	Canbus connection with protocol SAE J1939 and MTU for ECU engine control.
CanBus1	Canbus connection with protocol Mecc Alte PMCBus for the communication with other devices.
Rated impedance	120Ω
Insulation voltage	Max operating 560Vdc 1KVdc on transient < 60s.
<b>Ethernet Communication interface</b>	
Type of interface	1 Ethernet interface 10/100Mbps full-duplex 10T/100Tx Auto HP Auto-Mdix support Compliant IEE802.3/802.3u (Fast ethernet) Compliant ISO802-3/IEEE802.3 (10BASE-T)
Insulation voltage	1500VRMS
<b>HMI Communication interface (Optional)</b>	
Type of interface	1 RS485/422 serial port not insulated for the connection between the SCM (System Control Module) device and the HMI (Human Machine Interface) panel.
Rated impedance	120Ω
<b>Display</b>	
Type of display	TFT 4.3" colour display with white leds backlight
Resolution	480 x 272
Pixel Size	0,066 x 0,198 mm
Visual area dimensions	95 x 54 mm
<b>Environmental conditions</b>	
Operating temperature	From -25°C to +60°C
Stock temperature	From -30°C to +80°C
Moisture	IEC 60068-2-30 Db Damp Heat Cyclic 20/55°C @ 95% RH 48 Hours  IEC 60068-2-78 Cab Damp Heat steady state 40°C @ 93% RH 48 Hours
Operating altitude	Up to 2000 m (6561 ft.)
<b>Box</b>	
Material	Nylon66 + 30% fibreglass
Size	247(L) x 187(H) x 70(D) mm
Weight	1100g
Protection degree	IP55 with gasket for the front panel IP20 for the panel interior



## 14.1 Measurement resolution

<b>Mains and Genset voltage</b>	1Vrms
<b>Current</b>	Min. 0.1A (it depends on the CT ratio)
<b>Mains and Genset frequency</b>	0.1Hz ± 50ppm, 35ppm/C typical
<b>Power</b>	Min. 0.1 kW/kVA/kvar (it depends on the CT ratio)
<b>Power Factor</b>	0.01
<b>Energy</b>	1 kWh/kvarh
<b>Engine speed</b>	1 rpm
<b>Oil pressure</b>	0.1bar (below 10bar)
<b>Cooling liquid temperature</b>	0.1°C
<b>Oil temperature</b>	0.1°C
<b>Fuel level</b>	0.1%

## 15 Wirings to comply with marine certification

The wiring proposed in the following chapters refers to this application:

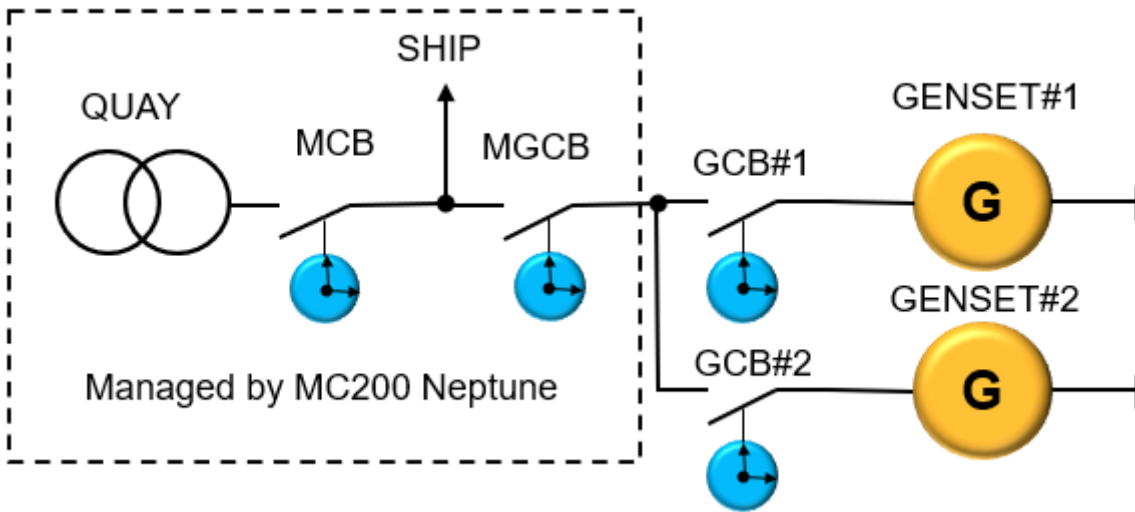

The application is made up by two generators (each controller by a “GC600 Neptune”) and the quay (controlled by the “MC200 Neptune”). Each generator has its own circuit breaker (GCB). The common busbars of the generators are connected to the loads (ship) through an additional circuit breaker (MGCB). The quay’s voltages are connected to the loads through the MCB circuit breaker. Synchronization is available on all circuit breakers.

Application made up by more than three generators can be managed taking care of the additional GCB in the following wirings descriptions. Application made up by just one generator can be managed removing all references to GCB#2 in the following wirings descriptions. Applications without MGCB can be managed considering MGCB always closed in the following wirings descriptions.

### 15.1 MCB circuit breaker feedback

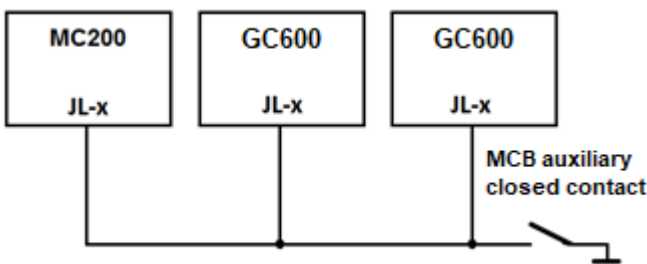

It is required to connect the real circuit breaker feedback to all controllers to allow the full application management even in case of no CANBUS communication between MC200 Neptune and the two GC600 Neptune. **Use one terminal of the JL connector (digital inputs 1...8) for this purpose.**

The default configuration of MC200 uses the digital input #2 (JL\_2) for this purpose (can be changed).

Configuration:

- Function for the input: “3002 – Status of the MCB circuit breaker”.

## 15.2 MGCB circuit breaker feedback

Required only if the MGCB circuit breaker really exists.

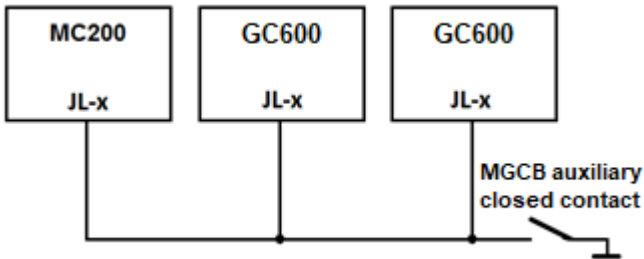

It is required to connect the real circuit breaker feedback to all controllers to allow the full application management even in case of no CANBUS communication between MC200 Neptune and the two GC600 Neptune. **Use one terminal of the JL connector (digital inputs 1...8) for this purpose.**

The default configuration of MC200 uses the digital input #1 (JL\_1) for this purpose (can be changed).

Configuration:

- Function for the input: “3003 – Status of the MGCB circuit breaker”.

## 15.3 GCB circuit breaker feedback

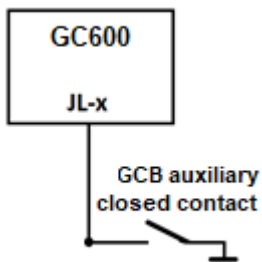

Each GC600 must acquire the feedback of its own GCB circuit breaker. In this case, we have no prescriptions about the connector to be used.

The default configuration of GC600 uses the digital input #1 (JL\_1) for this purpose (can be changed).

Configuration:

- Function for the input: “3001 – Status of the MCB circuit breaker”.

### 15.4 GCB circuit breakers feedback to MC200

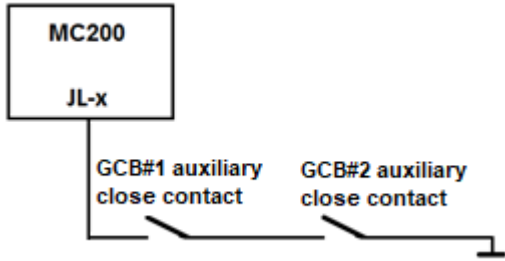

MC200 do normally acquire the GCB#1 and GCB#2 status over the CANBUS. To allow the full application management even in case of no CANBUS communication between MC200 Neptune and the two GC600 Neptune, this connection is required. In this case, we have no prescriptions about the connector to be used.

Configuration:

- Function for the input: “3004 – Status of the GCB circuit breaker of other gensets”.

### 15.5 “Dead bus” secondary check

Marine certification requires to have a double check on the voltage presence on the common busbars, allowing a safe management of the application even in case of failures in the voltage measure inputs of the controllers.

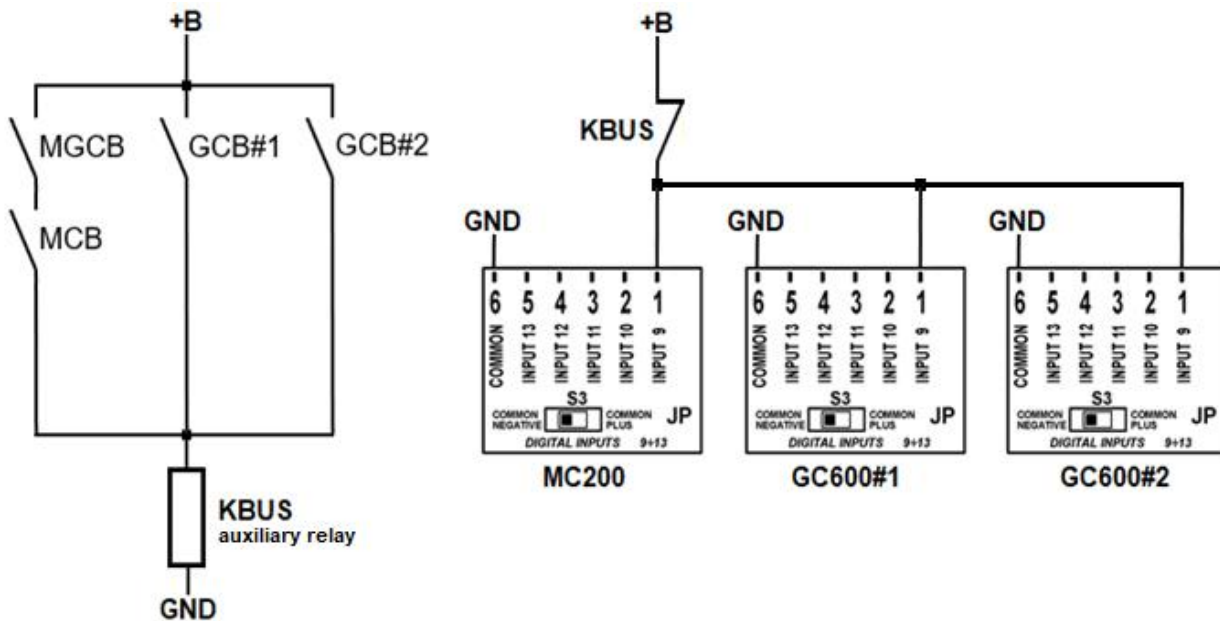

KBUS is a generic external relay. It will be energized when at least one generator or the quay is connected to the common busbars. In this situation, the controllers must never allow to close their circuit breakers without synchronization.

A normally closed contact of the auxiliary relay KBUS is connected to a digital input of all controllers. For safety reasons, each controller will consider the “dead busbars” condition when its input is activated: in case of broken wire, the input is not activated and the controller will consider “live bus”, not allowing circuit breaker closure without synchronization.

For more safety, we suggest using one input of the connector JP. These inputs can be optionally activated connecting them to a positive Vdc voltage, instead of standard grounding. To do this. The switch S3 must be placed in “negative common” position and a ground signal must be connected to terminal JP\_6. Using positive activation protects against floating wires in the panel (which can more probably touch a common ground instead touching a positive signal).



Configuration:

- Function for the input: “3102 – No voltages on the parallel bar”.

### 15.6 GCB closure electrical interlocks

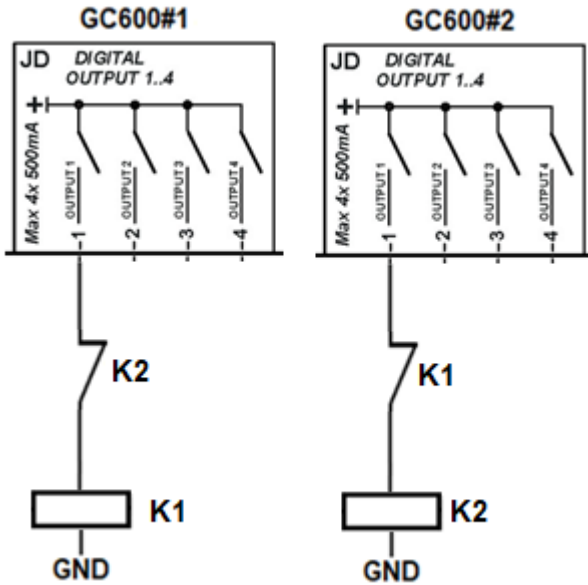

The GC600 controller perform a software interlock over the CANBUS. To ensure proper interlock even in case of CANBUS failure, the proposed circuit must be used. K1 and K2 are auxiliary relays. Use a “normally open” contact of K1 as closure command (pulse) for GCB#1. Use a “normally open” contact of K2 as closure command (pulse) for GCB#2.

You can use any digital output of the controller for this purpose. The outputs on JD connector provides positive voltage when activated, so they are suitable for the previous wiring diagram. If you are going to use outputs from connectors JQ or JR, connect “B+” to K1 and K2 instead of “GND”.



## 15.7 Speed command for synchronization

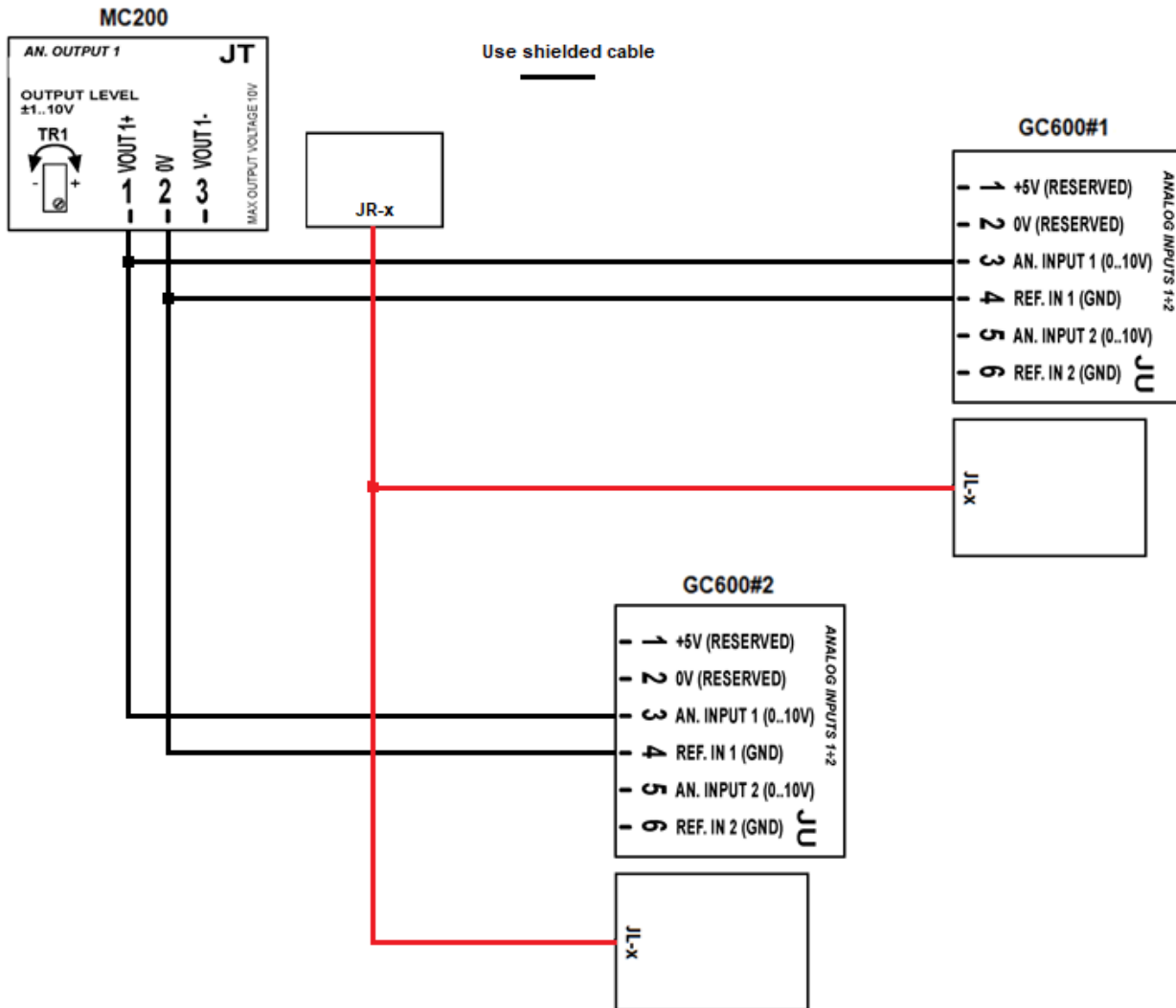

MC200 normally performs the synchronization digitally over the CANBUS. The previous wiring diagram is required to ensure that proper synchronization can be performed even in case of CANBUS failure. One analogue output of MC200 must be connected to two analogue inputs of the GC600. Since the analogue inputs of GC600 are 0-10Vdc, also the analogue output of MC200 must be 0-10Vdc. Thus, use terminals 1 & 2 of JT connector.

Moreover, one digital output of MC200 must be connected to a digital input of both GC600. It is used by MC200 to inform GC600 that the synchronization is required (GC600 will then properly manage the speed commands coming through its analogue input). **Use one terminal of the JL connector (digital inputs 1...8) for this purpose.** On MC200, you may use one terminal of the JR connector, which is suitable because it provides a negative signal.

Configuration:

- Function for the analogue output: “1000 – Speed regulator”.
- Function for the analogue input: “2105 – External synchronizer for MCB/MGCB”.
- Function for the digital output: “3093 – Synchronization in progress”.
- Function for the digital input: “1034 – Synchronization request for MCB/MGCB”.

## 15.8 Start command

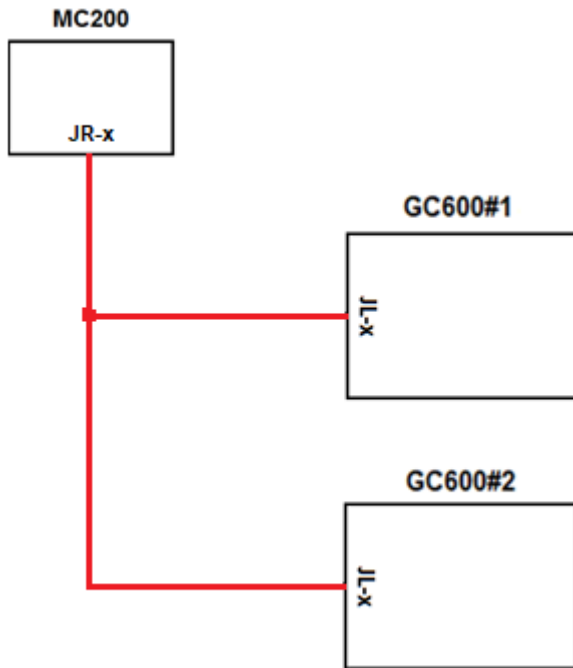

MC200 normally sends start/stop commands over the CANBUS. The previous wiring diagram is required to ensure that proper operation can be performed even in case of CANBUS failure.

One digital output of MC200 must be connected to a digital input of both GC600. It is used by MC200 to inform GC600 that the generator is required (GC600 will then properly start the engine, synchronize...). **Use one terminal of the JL connector (digital inputs 1...8) for this purpose.** On MC200, you may use one terminal of the JR connector, which is suitable because it provides a negative signal.

Configuration:

- Function for the digital output: "1005 – Start request".
- Function for the digital input: "2032 – Request for remote start mode".

## 15.9 Quay's voltage presence

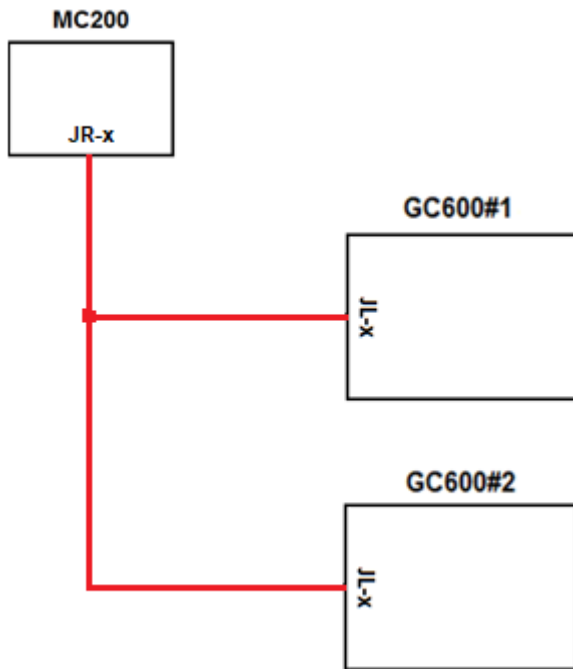

MC200 normally informs the other controllers about the quay's voltages status over the CANBUS. The previous wiring diagram is required to ensure that proper operation can be performed even in case of CANBUS failure.

One digital output of MC200 must be connected to a digital input of both GC600. It is used by MC200 to inform GC600 that the quay's voltages are present or not. **Use one terminal of the JL connector (digital inputs 1...8) for this purpose.** On MC200, you may use one terminal of the JR connector, which is suitable because it provides a negative signal.

Configuration:

- Function for the digital output: "3034 – Quay's voltages OK".
- Function for the digital input: "3103 – External quay's voltages sensor".



## MECC ALTE SPA (HQ)

Via Roma 20  
36051 Creazzo  
Vicenza – ITALY

T: +39 0444 396111  
F: +39 0444 396166  
E: [info@meccalte.it](mailto:info@meccalte.it)  
[aftersales@meccalte.it](mailto:aftersales@meccalte.it)

## MECC ALTE SMARTECH

Viale dell'Unione  
Europea, 33,  
21013 Gallarate  
VA – ITALY

E: [controllers@meccalte.com](mailto:controllers@meccalte.com)

## MECC ALTE PORTABLE

Via A. Volta 1  
37038 Soave  
Verona – ITALY

T: +39 0456 173411  
F: +39 0456 101880  
E: [info@meccalte.it](mailto:info@meccalte.it)  
[aftersales@meccalte.it](mailto:aftersales@meccalte.it)

## ZANARDI ALTERNATORI

Via Dei Laghi 48/B  
36077 Altavilla  
Vicenza – ITALY

T: +39 0444 370799  
F: +39 0444 370330  
E: [info@zanardialternatori.it](mailto:info@zanardialternatori.it)

## MECC ALTE POWER PRODUCTS

Via Melaro 2  
36075 Montecchio  
Maggiore (VI) – ITALY

T: +39 0444 1831295  
F: +39 0444 1831306  
E: [info@meccalte.it](mailto:info@meccalte.it)  
[aftersales@meccalte.it](mailto:aftersales@meccalte.it)

## UNITED KINGDOM

Mecc Alte U.K. LTD  
6 Lands' End Way  
Oakham  
Rutland LE15 6RF

T: +44 (0) 1572 771160  
F: +44 (0) 1572 771161  
E: [info@meccalte.co.uk](mailto:info@meccalte.co.uk)

## SPAIN

Mecc Alte España S.A.  
C/ Río Taibilla, 2  
Polig. Ind. Los Valeros  
03178 Benijofar (Alicante)

T: +34 (0) 96 6702152  
F: +34 (0) 96 6700103  
E: [info@meccalte.es](mailto:info@meccalte.es)

## CHINA

Mecc Alte Alternator (Nantong) Ltd  
755 Nanhai East Rd  
Jiangsu Nantong HEDZ 226100  
People's Republic of China

T: +86 (0) 513 82325758  
F: +86 (0) 513 82325768  
E: [info@meccalte.cn](mailto:info@meccalte.cn)

## INDIA

Mecc Alte India PVT LTD  
Plot NO: 1, Talegaon  
Dhamdhare S.O.  
Taluka: Shirur,  
District: Pune – 412208  
Maharashtra, India

T: +91 2137 673200  
F: +91 2137 673299  
E: [info@meccalte.in](mailto:info@meccalte.in)

## U.S.A. AND CANADA

Mecc Alte Inc.  
1229 Adams Drive  
McHenry, IL, 60051

T: +1 815 344 0530  
F: +1 815 344 0535  
E: [info@meccalte.us](mailto:info@meccalte.us)

## GERMANY

Mecc Alte Generatoren GmbH  
Bucher Hang 2  
D-87448 Waltenhofen

T: +49 (0)831 540755 0  
E: [info@meccalte.de](mailto:info@meccalte.de)

## AUSTRALIA

Mecc Alte Alternators PTY LTD  
10 Duncan Road, PO Box 1046  
Dry Creek, 5094,  
South Australia

T: +61 (0) 8 8349 8422  
F: +61 (0) 8 8349 8455  
E: [info@meccalte.com.au](mailto:info@meccalte.com.au)

## FRANCE

Mecc Alte International S.A.  
Z.E. la Gagnerie  
16330 St. Amant de Boixe

T: +33 (0) 545 397562  
F: +33 (0) 545 398820  
E: [info@meccalte.fr](mailto:info@meccalte.fr)

## FAR EAST

Mecc Alte (F.E.) PTE LTD  
10V Enterprise Road, Enterprise 10  
Singapore 627679

T: +65 62 657122  
F: +65 62 653991  
E: [info@meccalte.com.sg](mailto:info@meccalte.com.sg)



[www.meccalte.com](http://www.meccalte.com)



The world's largest independent  
producer of alternators 1 – 10,000kVA

File Name: EAAM068503EN.docx  
Rev. 03 Date: 27/02/2026  
Document ID: EAAM0685  
Product: GC600 & MC200 Neptune