



Totally Focused. Totally Independent.

EN

User manual

Self-regulating Alternators

Series ECP 4
Series ECP 28
Series ECP 30
Series ECP 32
Series ECP 34



Operating and maintenance instructions

Code: Series ECP-C
Revision: 2
Date: 02/2024

Translation of original language



The world's largest
independent producer of
alternators 1 - 5,000kVA

Contents	1
1 General Information: scope of the manual	1
1.1 Intended Users	1
1.2 Professional Profiles Involved	1
1.3 Manual use and storage	1
1.4 How to consult the manual	3
1.4.1 Description of the symbols/pictographs in the manual	3
1.5 Reference Regulations and Directives	4
1.6 Marking data	5
1.7 Declaration of Conformity	6
1.8 Support	8
1.9 Glossary	8
2 Alternator Overview	9
2.1 Main components	9
2.1.1 DSR Digital Regulator	10
2.1.2 DER1 Digital Regulator	10
2.2 General description and working principle	10
2.3 Technical Data	11
2.3.1 IP Protection Rating	11
2.3.2 Radial Loads	11
2.3.3 Noise level [dB(A)]	11
2.3.4 Weight	12
2.3.5 Air volumes [m ³ /min] for local alternators	13
2.3.6 Alignment tolerances in B3B14	13
2.3.7 Positioning dimension in MD35	13
2.3.8 Resistance of windings at 20°C ambient temperature	13
2.3.9 Overall dimensions	16

2.3.10 Materials	24
2.4 Operating ambient requirements	24
3 Safety	25
3.1 General Instructions	25
3.2 Alternator Safety devices	26
3.3 Safety tags	27
3.4 Personal Protective Equipment	28
3.5 Residual risks	28
4 Transportation, movement and storage	29
4.1 General Instructions	29
4.2 Packing materials lifting and transportation	30
4.3 Unpacking	30
4.4 How to dispose of the packing materials	30
4.5 Alternator Movement	31
4.6 Storage	31
5 Installation instructions / drive motor coupling	33
5.1 Installation Setup	33
5.2 Unpacking and disposal of packing materials	33
5.3 Mechanical coupling	34
5.3.1 Alternator Preparation	35
5.3.2 Aligning the drive motor to the B3B14 alternator	35
5.3.3 Aligning the drive motor to the MD35 alternator	36
5.3.4 Thermal Expansion Compensation	36
6 Electrical connection	39
6.1 Terminal board configurations	41
6.1.1 ECP 4 regulation box	42
6.1.2 ECP 28 / ECP 30 regulation box	44

6.1.3 ECP 32 regulation box	46
6.1.4 ECP 34 regulation box	48
6.2 Parallel connection of alternators	50
6.2.1 Installation of a parallel device	50
7 Startup Instructions	53
8 Electronic regulators	55
8.1 DSR Digital Regulator	55
8.1.1 Stability Adjustment	56
8.1.2 Protections	58
8.1.3 Inputs and Outputs: technical specifications	59
8.2 DER1 Digital Regulator	62
8.2.1 Stability Adjustment	63
8.2.2 Protections	65
8.2.3 Inputs and Outputs: technical specifications	66
8.3 UVR6-SR7 analog regulators	70
9 Maintenance	73
9.1 General Instructions	73
9.2 Maintenance summary table	74
9.2.1 Summary table of ordinary maintenance operations	74
9.2.2 Summary table of extraordinary maintenance operations	74
9.2.3 Summary table of maintenance operations in case of failure	75
9.3 Ordinary Maintenance	76
9.3.1 General cleaning	76
9.3.2 Air filter cleaning (if present)	77
9.3.3 Visual Inspection	78
9.3.4 Verification of winding state	79
9.3.5 Verification of correct alternator operation	80

9.3.6 Tightening torque check	80
9.3.7 Alternator exterior and interior cleaning	81
9.4 Extraordinary maintenance	82
9.4.1 Maintenance and potential replacement of bearings	82
9.4.2 Winding state and diode bridge fastening check	83
9.4.3 Copy of the alarms of the digital regulator	83
9.4.4 Cleaning of windings	84
9.5 Maintenance in case of failure	85
9.5.1 Fan replacement assembly	85
9.5.2 Verification and potential replacement of diode bridge	87
9.5.3 Mechanical disassembly for inspection	89
9.5.4 Mechanical assembling	94
9.5.5 Removal of disc holder hub (34 series)	97
9.5.6 Loss of residual magnetism (reexcitation of the machine)	99
9.5.7 Verification and replacement of voltage regulator	100
9.5.8 DSR test and setup on test bench	103
9.5.9 DER1 test and setup on test bench	105
9.5.10 Main stator windings voltage test	107
9.5.10.1 Resistance/Continuity Test	108
9.5.10.2 Insulation Test	109
9.6 General Tightening Torques	111
9.6.1 ECP4 C Series	111
9.6.2 ECP28 C Series	113
9.6.3 ECP30 C Series	115
9.6.4 ECP32 C Series	117
9.6.5 ECP34 C Series	119
9.7 Disc Tightening Torques	120

9.8 Terminal block Tightening Torques	122
10 DSR / DER1 alarm management	123
10.1 DSR/DER1 digital regulator alarms	124
11 Problems, causes and solutions	127
12 Electrical diagrams	129
12.1 DSR digital regulator electrical diagrams	130
12.2 DER 1 digital regulator electrical diagrams	133
12.3 Electrical diagrams with UVR6 - SR7 regulators	139
13 Replacement parts	145
13.1 ECP 4C / 4 mounting form MD35	146
13.2 ECP 28C/4 - Mounting form MD35	148
13.3 ECP 28C/4 mounting form B3B14	150
13.4 ECP 30C/4 - Mounting form MD35	152
13.5 ECP 32C / 4 mounting form MD35	154
13.6 ECP 32C / 4 mounting form B3B14	156
13.7 ECP 34C / 4 mounting form MD35	158
13.8 ECP 34C/4 mounting form B3B14	160
14 Dismantlement and disposal	163

1 General Information: scope of the manual

This manual is intended to provide support and guidance during the stages of work on the alternator. It contains information on the use, maintenance and handling of faults and malfunctions providing indications for the most adequate behavior to the correct use and to the correct operation of the machine as specified by the Manufacturer.

This manual is an essential safety requirement and it must accompany the alternator throughout its life cycle. It is indispensable to store this manual and to make it available to everyone involved in using and servicing the alternator.



This document and/or its parts may not be reproduced or disclosed to third parties without the prior consent of MECC ALTE S.p.A.



MECC ALTE S.p.A. is not responsible or liable for any damages suffered by people or things as a result of improper use not indicated in this manual and by failure to comply with the specifications of the technical characteristics table pertaining to every model.

1.1 Intended Users

This manual is intended for the authorized personnel adequately trained to operate this kind of product.

Warning



The operators must not carry out operations reserved to maintenance technicians or to specialized technicians. The Manufacturer disclaims all responsibility for damages suffered as a result of failure to comply with this warning.

1.2 Professional Profiles Involved

Below we describe the professional profiles who may operate the alternator based on the kind of activity to be carried out.

Handler



Authorized skilled personnel able to safely lift and handle the alternator. The operator is not authorized to carry out maintenance operations.

Mechanical maintenance technician



A qualified technician able to carry out the installation, adjustment, maintenance and ordinary repair operations required. Not allowed to carry out operations with the power on.

Electrical Maintenance Operator



A qualified technician in charge with all the electrical works of connection, adjustment, maintenance and repair. Authorized to carry out operations with the power on.

Field Service Technician



A qualified technician provided by the manufacturer to carry out complex operations in special cases or, anyway, as previously agreed with the user.

1.3 Manual use and storage

Warning



Read this manual carefully before starting up the alternator or carrying out any operation on it. If you do not read it you might not be able to recognize potential hazardous situations that may lead to death or serious injuries inflicted to yourself or to others.

This manual is intended to provide all the information required for a correct use of the alternator and its most autonomous and safest possible management.

It is mandatory for all the users and the maintenance technicians to carefully read the instructions contained in this manual and in all possible annexes, before carrying out any operation on the product.

In case of doubts on the correct interpretation of the information reported in the documentation, please contact the manufacturer for clarifications.

Caution



Keep this manual and all its annexes in good condition, legible and complete in all its parts. Keep the documentation close to your alternator, in an accessible place known to all the operators and maintenance technicians and, more generally, to everyone who for various reasons should operate the alternator.

Warning



Keep the manual in its original condition. It is forbidden to rewrite, change or remove pages from the manual and their contents. The manufacturer disclaims all responsibility for any potential damages to people, animals or things as a result of failure to comply with the instructions and with the operational modalities described in this manual.



This manual is an integral part of the alternator and it must be stored for future reference.

Caution



This manual must be delivered together with the alternator in case the alternator is transferred/sold to another user.

Caution



In case the manual is lost or damaged ask for a copy from the Manufacturer indicating its identification data: document name, code, revision number and issue date.

1.4 How to consult the manual

- The manual is divided in chapters, paragraphs and subparagraphs listed in the table of contents: an easy way to find any topic of interest.
- The symbols used provide direct knowledge on the kind of information expressed by each symbol. For instance the symbol:



This symbol indicates a NOTE.

1.4.1 Description of the symbols/pictographs in the manual

Below you will find the various symbols used in the manual to highlight information of particular importance or the intended recipients of the specific pieces of information.



Danger

The risks described in this manner indicate a HIGH LEVEL of hazard that, unless avoided, could cause severe injuries or death.



Warning

The risks described in this manner indicate an INTERMEDIATE LEVEL of hazard that, unless avoided, could cause severe injuries or death.



Caution

The risks described in this manner indicate a LOW LEVEL of hazard that, unless avoided, could cause minor or moderate injuries.



This symbol indicates a NOTE; a fundamentally important piece of information or in-depth explanation.



This symbol indicates a CROSS REFERENCE; the presence of a module, of a drawing or of an annexed document that should be consulted and, if required, filled in.

1.5 Reference Regulations and Directives

List of the reference regulations and directives used for the design and construction of the alternator.

Directives

- Machinery Directive 2006/42/EC.
- Low Voltage Directive 2014/35/EC.
- EMC Directive 2014/30/EC.
- RoHS2 Directive 2011/65/EC.
- RoHS3 Directive 2015/863/EC.

Applicable Harmonized Technical Standards

- EN ISO 12100 (2010) : Safety of machinery – General principles of design – Risk assessment and risk reduction
- EN 60034-1 : Rotating Electrical Machines - Part 1 : Rating and performance.
- EN 60204-1: Safety of machinery. Electrical equipment of machines. Part 1: General Requirements
- EN61000-6-3 : Electromagnetic Compatibility (EMC) Part 6-3: Generic Standards - Emission standard for Residential, Commercial and Light-industrial Environments.
- EN61000-6-2 : Electromagnetic Compatibility (EMC) Part 6-2: Generic Standards - Immunity for industrial environments

Applicable Technical Standards

- EN 60034-2 : Method for determining losses and efficiency
- EN 60034-5 : Classification of degrees of protection (IP).
- EN 60034-6 : Methods of cooling (IC)
- EN 60034-7 : Types of construction (IM code)
- EN 60034-8 : Terminal markings and direction of rotation
- EN 60034-9 : Noise limits
- EN 60034-14 : Mechanical vibration limits
- EN 60085 : Classification of insulating materials
- ISO 1940-1 : Balance quality requirements of rigid rotors

Technical standards to be applied by the installer

- ISO 8528-9 : Reciprocating internal combustion engine driven alternating current generating sets Part 9: Measurement and evaluation of mechanical vibrations.

1.6 Marking data

Alternator Nameplate

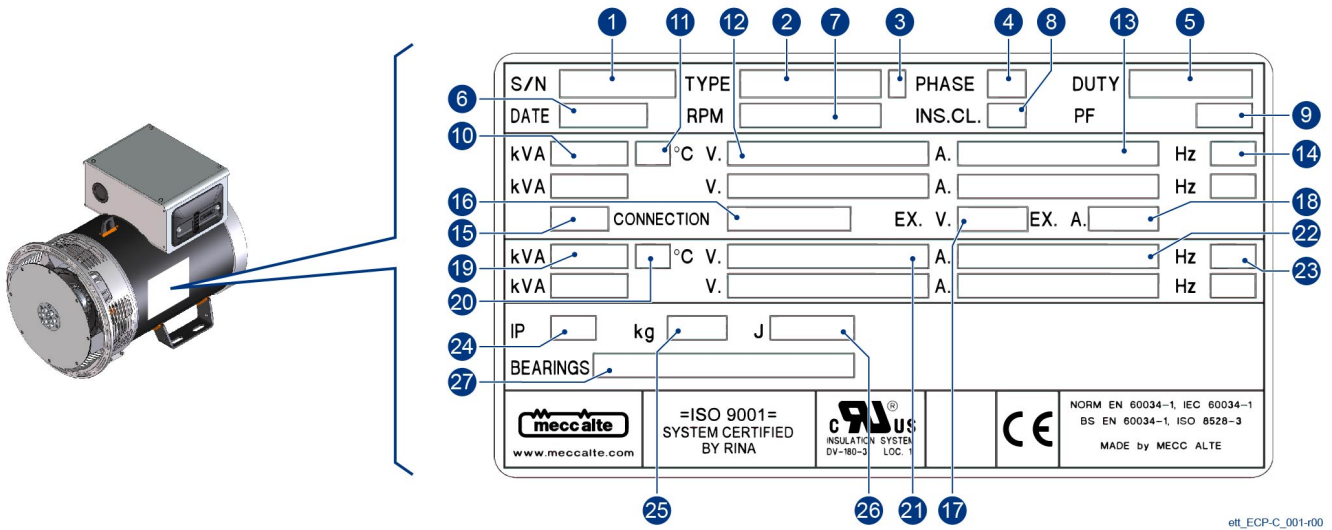

- | | |
|-----------------------------------------------|---------------------------------------|
| 1. Serial number | 15. Nominal characteristics class |
| 2. Model | 16. Connection type |
| 3. Revision index | 17. Excitation Voltage |
| 4. Phase number | 18. Excitation Current |
| 5. Service type | 19. Power related to temperature (20) |
| 6. Manufacture month / year | 20. Ambient temperature |
| 7. Nominal speed | 21. Nominal Voltage |
| 8. Insulation class | 22. Current related to power (19) |
| 9. Power factor | 23. Nominal Frequency |
| 10. Nominal power related to temperature (11) | 24. Protection Rating |
| 11. Maximum ambient temperature | 25. Total weight |
| 12. Nominal Voltage | 26. Moment of inertia |
| 13. Nominal Current | 27. Bearing type |
| 14. Nominal Frequency | |





Ask for a new nameplate if the one attached to the alternator cannot be read anymore.

The nameplate is affixed on the alternator in the position indicated in the figure.

1.7 Declaration of Conformity

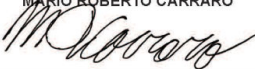

Below a copy of the declaration of conformity of the product. The original is placed inside the terminal box of every alternator. A true copy may be requested in case of loss.

 CONFORMITY DECLARATION DICHIARAZIONE DI CONFORMITÀ DECLARATION DE CONFORMITÉ KONFORMITÄTS ERKLÄRUNG DECLARACION DE CONFORMIDAD www.meccalte.com				
Mecc Alte declares under its sole responsibility that the machine	Mecc Alte dichiara sotto la propria esclusiva responsabilità che la macchina	Mecc Alte déclare sous sa seule responsabilité que la machine	Mecc Alte erklärt in alleiniger Verantwortung, dass die Maschine	Mecc Alte declara bajo su exclusiva responsabilidad que la máquina
<div style="border: 1px solid black; width: 200px; height: 50px; margin: 0 auto;"></div>				
as described in the attached documents, files, is in conformity with	così come descritta nei documenti allegati, fascicoli, è conforme a	telle que décrite dans les documents, fichiers joints est conforme à	wie in den beigefügten Dokumenten, Dateien beschrieben, konform ist mit	tal como se describe en los documentos adjuntos, archiva es conforme con
 2006/42/EC, 2014/35/EU, 2014/30/EU, 2011/65/EU, 2015/163, EN ISO 12100, EN 60204-1, EN IEC 61000-6-2, EN IEC 61000-6-3, EN 60034-1				
 BS EN ISO 12100, BS EN 60204-1, BS EN IEC 61000-6-2, BS EN IEC 61000-6-3, BS EN 60034-1, Electromagnetic Compatibility Regulations 2016, Electrical Equipment (Safety) Regulations 2016, Supply of Machinery (Safety) Regulations 2016				
This machine must not be put into service until the machine in which it is intended to be incorporated into, has been declared to be in conformity with the provisions of 2006/42/CEE Machinery Directive.	Questa macchina non deve essere messa in servizio fino a quando la macchina in cui è destinata ad essere incorporata, non sia stata dichiarata conforme alle disposizioni della Direttiva Macchine 2006/42/CEE.	Cette machine ne doit pas être mise en service tant que la machine dans laquelle elle est destinée à être intégrée n'a pas été déclarée conforme aux dispositions de la Directive Machines 2006/42/CEE.	Diese Maschine darf nicht in Betrieb genommen werden, bis die Maschine, in die sie eingebaut werden soll, für konform mit den Bestimmungen der Maschinenrichtlinie 2006/42/EWG erklärt wurde.	Esta máquina no debe ponerse en servicio hasta que la máquina en la que se pretende incorporar haya sido declarada conforme a las disposiciones de la Directiva de Máquinas 2006/42/CEE.
This declaration is in conformity with the general criteria indicated by EN 17050 European Standard.	Questa dichiarazione è conforme ai criteri generali indicati dalla norma europea EN17050.	Cette déclaration est conforme aux critères généraux indiqués par la norme européenne EN17050.	Diese Erklärung entspricht den allgemeinen Kriterien der europäischen Norm EN17050.	Esta declaración está en conformidad con los criterios generales indicados por la Norma Europea EN17050.
This machine was produced in:	Questa macchina è stata prodotta a:	Cette machine a été produite en:	Diese Maschine wurde produziert:	Esta máquina se produjo en:
<input type="checkbox"/> MECC ALTE via ROMA 20, 36051 Creazzo, Vicenza ITALY P.IVA 01267440244 TEL +39 0444 396111 FAX +39 0444 396166 info@meccalte.it	<input type="checkbox"/> MECC ALTE UK LTD 6 LAND'S END WAY Oakham Rutland UK VAT GB 690 7302 32 TEL +44 01572 771160 FAX +44 01572 771161 info@meccalte.co.uk	<input type="checkbox"/> MECC ALTE ALTERNATOR (NANTONG) Ltd 755, NANHAI EAST ROAD JIANGSU NANTONG HEDZ 226100 PRC VAT 320694785587760 TEL (86) 513-82325758 FAX (86) 513-82325768 info@meccalte.cn	<input type="checkbox"/> MECC ALTE INDIA PVT LTD PLOT No 1 TELAGON DHAMDHERE S.O. TALUKA: SHIRUR, DISTRICT: PUNE 412208 MAHARASHTRA, INDIA TEL +91 2137 873200 FAX +91 2137 873299 info@meccalte.in	
Position Posizione Position Stelle Posición First name and surname Nome e cognome Nom et prenom Vor-und Nachname Nombre y apellido Signature Firma Signature Unterschrift Firma				L'Amministratore Delegato MARIO ROBERTO CARRARO 

RESIDUAL RISKS LIST

The manufacturer MECC ALTE took all possible precautions to construct the generator following all safety regulations and present applicable Safety Norms.

The instruction manual explains step by step all indications required in point 1.7.4 (user instructions) of the Machines Directive and all users are specifically asked to read it carefully in order to avoid wrong operations which, even though simple, could cause damage to persons. If all instructions given are followed, no residual risks are left; however, one has to pay attention to the warnings given :

- 1) move carefully the generator (packed and unpacked)
- 2) the coupling of the generator with the drive-machine and the electrical connections should be performed by skilled personnel
- 3) do not touch the generator during function and immediately after being stopped since some parts of the generator could be hot
- 4) in case of generator with permanent magnets, take proper precautions and keep appropriate distance.

LISTA RISCHI RESIDUI

La MECC ALTE ha fatto tutto il possibile per fabbricare il generatore con il massimo della conoscenza sulle sicurezze. Suo possesso e consultando tutte le Direttive e Norme attualmente applicabili.

Il manuale d'uso ed istruzione riporta passo-passo tutte le indicazioni richieste dal punto 1.7.4 (istruzioni d'uso) della Direttiva Macchine ed è fatta specifica richiesta di leggerlo attentamente così da non incorrere in operazioni errate che, se pur minime, possono causare danni alle persone. Se vengono rispettate tutte le indicazioni fornite, non rimangono particolari rischi residui, ma solamente delle attenzioni da seguire.

- 1) movimentare il generatore con accortezza (imballato e disimballato)
- 2) far accoppiare il generatore alla macchina di trascinamento e far collegare elettricamente lo stesso, da personale adeguatamente istruito
- 3) non toccare il generatore durante il funzionamento e subito dopo l'arresto dello stesso, in quanto vi potrebbe essere parti del generatore a temperature elevate
- 4) se il generatore presenta magneti permanenti all'interno, prendere le dovute precauzioni e mantenere le giuste distanze.

LISTE DES RISQUES RÉSIDUELS

La société Mecc Alte a pris toutes ses précautions pour fabriquer les alternateurs avec le maximum de sécurité à sa connaissance, et en consultant toutes les directives et normes actuellement applicables.

Le manuel d'utilisation et d'instruction explique point par point toutes les indications requises au point 1.7.4 (instruction d'utilisation) de la Directive des Machines, et tous les utilisateurs sont spécifiquement sollicités à lire attentivement avec attention afin d'éviter toutes fausses opérations qui, même minimes, peuvent être dangereuses pour l'utilisateur. Si toutes les instructions données sont suivies, il n'y a aucun risque résiduel particulier, mais seulement quelques précautions à prendre qui sont :

- 1) manipuler l'alternateur avec prudence (emballage et déemballage)
- 2) effectuer l'accouplement entre l'alternateur avec le système d'entraînement et les connexions électriques par du personnel qualifié
- 3) ne pas toucher l'alternateur durant son fonctionnement et aussitôt après son arrêt, car certaines pièces peuvent encore être à température élevée
- 4) Dans le cas d'un générateur à aimants permanents, prendre les précautions appropriées et garder une distance appropriée.

LISTE DER NACHBLEIBENDEN GEFAHREN

Der Hersteller MECC ALTE hat alle möglichen Vorsichtsmaßnahmen bei der Herstellung des Generators nach geltenden Sicherheitsvorschriften und den z.Zt. anwendbaren Sicherheitsnormen eingehalten.
Die Bedienungsanleitung erklärt schrittweise alle Indikatoren, die in Pkt.1.7.4 (Gebrauchsanweisung) der Maschinenbauvorschrift gefragt sind. Alle Anwender werden dringend gebeten, diese aufmerksam zu lesen, um auch den kleinsten Fehler zu vermeiden, der Personenschaden verursachen könnte. Bei genauer Beachtung der Vorschriften verbleibt kein Risiko; jedoch müssen die folgenden Warnungen beachtet werden :

- 1) den Generator (verpackt und unverteilt) vorsichtig transportieren
- 2) die Kopplung des Generators mit der Antriebsmaschine und die elektrischen Verbindungen nur durch qualifiziertes Personal ausführen lassen
- 3) den Generator während des Betriebs und kurz nach dem Abstellen nicht berühren, da Teile des Generators heiß sein können
- 4) Bei Generatoren mit Dauermagneten sind entsprechende Vorsichtsmaßnahmen zu treffen und ein angemessener Abstand einzuhalten.

LISTA DE LOS RIESGOS RESIDUALES

La MECC ALTE ha hecho todo el posible para fabricar el generador con los máximos conocimientos sobre seguridad en su poder, y consultando todas las directivas y normas actualmente aplicables.

El manual de uso e instrucciones explica paso a paso todas las indicaciones requeridas por el punto 1.7.4 (instrucciones de uso) de la Directiva Máquinas, y hace una particular solicitud de leer atentamente el mismo, de manera de evitar operaciones erradas, que si bien mínimas, podrían provocar daños a las personas. Si son respetadas todas las indicaciones dadas, prácticamente no quedan riesgos residuales, a parte los siguientes puntos:

- 1) manipular el generador con cuidado (embalado y desembalado)
- 2) acoplar el generador con la máquina que da el movimiento primario, y conectar eléctricamente el mismo, por personal adecuadamente calificado
- 3) no tocar el generador durante el funcionamiento, así como, inmediatamente después que el mismo se detiene, debido a que podrían existir partes del generador a altas temperaturas
- 4) en caso de generador con imanes permanentes, tome las debidas precauciones y mantenga la distancia apropiada.

1.8 Support

For any inquiry on the use, the maintenance or a request of replacement parts, the buyer must contact the Manufacturer directly (or the help desk if present), specifying the alternator identification data indicated on the nameplate.

The Customer may resort to the technical and commercial support provided by the area representatives or by foreign branches, which are in direct contact with MECC ALTE S.p.A. and have their addresses and contact data indicated on the back cover.

In case of fault or an insurmountable inconvenience, the Customer may contact directly the headquarters using the following data:

PHONE NUMBER (Landline):	+ 39 0444 396111
E-MAIL:	aftersales@meccalte.it
WEBSITE:	www.meccalte.com
MAILING ADDRESS:	MECC ALTE S.p.A Via Roma 36051 Creazzo, Vicenza Italy



In case of ownership transfer or company transfers of the alternator you should always inform the manufacturing company or your reference help desk.

1.9 Glossary

System:	System means, in brief, the drive motor and the alternator.
Installer:	A person / company that is in charge of building the "Fully assembled Machine" and/or installing it at the user's premises.
Fully Assembled Machine:	It is the name of the complete machine mainly made up of a "drive motor" and the alternator.
Drive motor:	It is the motor to which the alternator is connected. The manual also defines it as the "drive machine".
PPE:	Personal Protective Equipment.

2 Alternator Overview

ECP Series alternators are self-regulated, 2 or 4-pole brushless alternators.

They are equipped with a rotating inductor (1) fitted with a damper cage and stationary armature with inclined grooves.

The winding is short pitched so as to reduce the harmonics.

The electromagnetic compatibility tests were carried out in compliance with the standard specifications, with the neutral wire connected to ground.

Testing in accordance with other specifications may be carried out on request of the customer.

The mechanical structure, always very robust, allows easy access to the connections and inspections of the various components.

The case is made of steel, the shields are made of aluminium/cast iron, the shaft is made of C45 steel with a fan splined onto the shaft.

The protection rating is IP23 (higher protection ratings can be achieved on request).

Insulation is of class H standard.

The impregnations are realized with polyester resin for the rotating parts and with vacuum treatment for the parts that have higher voltage such as for instance the stators.

Special treatments may also be carried out on request.

2.1 Main components

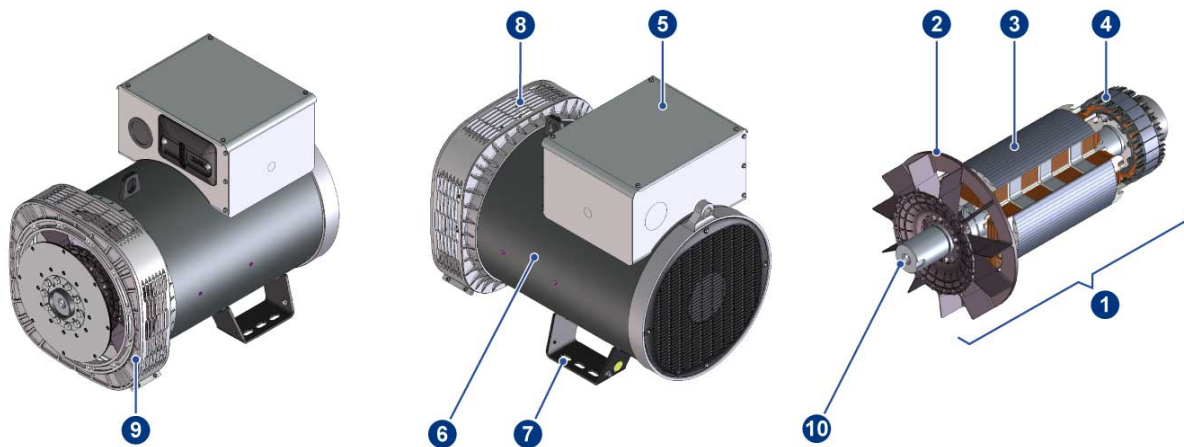

ds_ECP-C_021-r00

- | | |
|----------------------|--------------------|
| 1. Rotating Inductor | 7. Mounting Feet |
| 2. Cooling fan | 8. Protection Grid |
| 3. Main rotor | 9. Front Cover |
| 4. Exciter Rotor | 10. Shaft |
| 5. Terminal Box | |
| 6. Stator Frame | |

2.1.1 DSR Digital Regulator

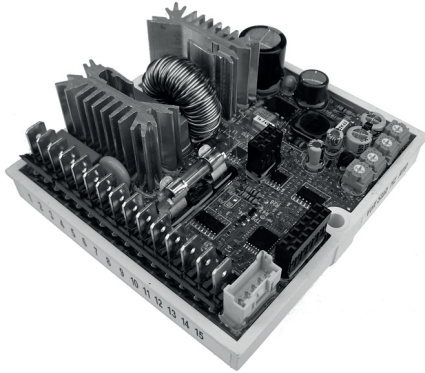

dis_ECO_022-r00

Standard supply comes with the DSR on the 4-28-30-32-34 series.

The regulator is normally installed in the alternator terminal box.

2.1.2 DER1 Digital Regulator

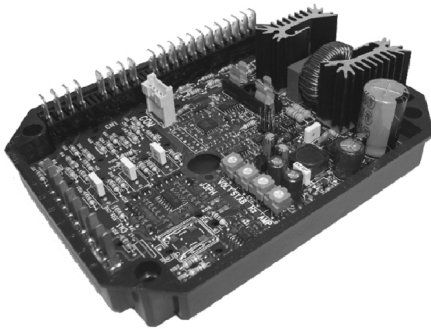

dis_ECO_023-r00

On customer request, it is possible to mount DER1 on 4-28-30-32-34 series

The regulator is normally installed in the terminal box of the alternator.

2.2 General description and working principle

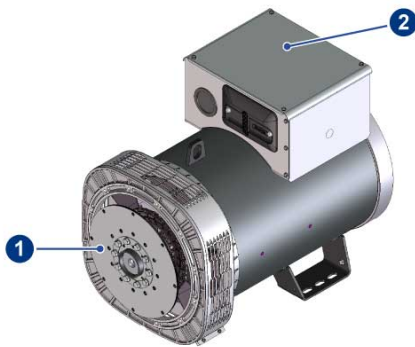

dis_ECP-C_030-r00

The drive motor is connected to the flange and disks (1) of the alternator.

The alternator rotor, started up by the drive motor, generates electricity.

The cables for the electric power supply to the user are connected on the terminal block inside the "terminal box" (2).

The DSR/DER1 digital regulators are equipped with an LED Indicator. During normal operation the LED blinks with a 2-second period and a 50% duty cycle (1 second on, 1 second off), in case of faults it flashes differently.



See diagrams in chapter 10 "Alarm Management".

2.3 Technical Data

2.3.1 IP Protection Rating

The alternator is built with an IP23 protection rating.

2.3.2 Radial Loads

Maximum allowable radial loads applied to shaft projection, for double-bearing alternators.

Series	Radial Force [N]
ECP 4	/
ECP 28	4000
ECP 30	/
ECP 32	5200
ECP 34	9000

2.3.3 Noise level [dB(A)]

Series 4 pole	50 Hz		60 Hz	
	1 m	7 m	1 m	7 m
ECP 4	70	57	74	60
ECP 28	68	57	71	61
ECP 30	72	59	78	62
ECP 32	72	58	76	62
ECP 34	79	65	83	69

2.3.4 Weight



Weights for MD35 construction type alternators.

Series 4 pole	Model	Weight [Kg]
ECP 4	1M4 C	56
	2M4 C	61
	3M4 C	65
	4M4 C	72
	5M4 C	79
	1L4 C	93
	2L4 C	97
ECP 28	1VS4 C	73
	2VS4 C	79,1
	1S4 C	87,4
	2S4 C	91.5
	3S4 C	96.9
	M4 C	106
	L4 C	121.9
ECP 30	VL4 C	141.8
	1M4 C	105
	2M4 C	118
	3M4 C	130
	1L4 C	148
	2L4 C	158
	ECP 32	1S4 C
2S4 C		165
1M4 C		186
2M4 C		212
1L4 C		244
2L4 C		252
ECP 34	1S4 C	302
	2S4 C	349
	1M4 C	370
	2M4 C	388
	1L4 C	423
	2L4 C	440

2.3.5 Air volumes [m³/min] for local alternators

Series 4 pole	50 Hz	60 Hz
ECP 4 C	4.4	5.2
ECP 28 C	6.6	8
ECP 30 C	13.5	16.2
ECP 32 C	15.7	18.5
ECP 34 C	29.2	34.4

2.3.6 Alignment tolerances in B3B14

Tolerance table of drive motor alignment with the alternator.

RPM	Radial tolerance (mm)	Angular tolerance (mm / 100 mm)
1500	0.06	0.05
1800	0.05	0.05

2.3.7 Positioning dimension in MD35

Positioning dimension for flywheel referred to flange face (see drawing at paragraph 5.3.3)

Series	SAE	L (mm)
ECP 4	6 ½	30.2
	7 ½	30.2
	8	62
	10	53.8
	11 ½	39.6
ECP 28	6 ½	30.2
	7 ½	30.2
	8	62
	10	53.8
	11 ½	39.6
ECP 30	6 ½	30.2
	7 ½	30.2
	8	62
	10	53.8
	11 ½	39.6
ECP 32	6 ½	30.2
	7 ½	30.2
	8	62
	10	53.8
	11 ½	39.6
ECP 34	10	53.8
	11 ½	39.6
	14	25.4

2.3.8 Resistance of windings at 20°C ambient temperature

Resistance of windings at 20°C ambient temperature						
Alternators 4 pole						
Type	V/Hz	Alternator			Exciter	
		Stator $\Omega (\pm 5\%)$	Rotor $\Omega (\pm 5\%)$	Auxiliary winding $\Omega (\pm 5\%)$	Stator $\Omega (\pm 5\%)$	Rotor PHAS E- PHAS E $\Omega (\pm 5\%)$
ECP4 1M4 C	115/200/230/400 - 50	1.55	6.3	4.02	14.2	2.15
ECP4 2M4 C	115/200/230/400 - 50	1.069	7.3	4.9	14.2	2.15
ECP4 3M4 C	115/200/230/400 - 50	0.765	8.7	3.8	14.2	2.15
ECP4 4M4 C	115/200/230/400 - 50	0.547	8.8	4.2	14.2	2.15
ECP4 5M4 C	115/200/230/400 - 50	0.435	10.3	3.9	14.2	2.15
ECP4 1L4 C	115/200/230/400 - 50	0.316	11.7	3.7	14.2	2.15
ECP4 2L4 C	115/200/230/400 - 50	0.27	12.3	3.8	14.2	2.15
ECP28 1VS4 C	115/200/230/400 - 50	1.101	0,904	6.056	9.6	0,384
ECP28 2VS4 C	115/200/230/400 - 50	0,737	0.986	5.270	9.6	0,384
ECP28 1S4 C	115/200/230/400 - 50	0,542	1,067	4.837	9.6	0,384
ECP28 2S4 C	115/200/230/400 - 50	0,396	1,123	4.459	9.6	0,384
ECP28 3S4 C	115/200/230/400 - 50	0,347	1,204	1.624	9.6	0,384
ECP28 M4 C	115/200/230/400 - 50	0,276	1,314	1.479	9.6	0,384
ECP28 L4 C	115/200/230/400 - 50	0,183	1,505	1.444	9.6	0,384
ECP28 VL4 C	115/200/230/400 - 50	0,141	1,75	1.434	9.6	0,384
ECP30 1M4 C	115/200/230/400 - 50	0.235	1.295	2.25	9.6	0.384
ECP30 2M4 C	115/200/230/400 - 50	0.174	1.512	2.21	9.6	0.384
ECP30 3M4 C	115/200/230/400 - 50	0.15	1.684	2.23	9.6	0.384
ECP30 1L4 C	115/200/230/400 - 50	0.134	1.867	2.17	9.6	0.384
ECP30 2L4 C	115/200/230/400 - 50	0.111	2.016	2.19	9.6	0.384

ECP32 1S4 C	115/200/230/400 - 50	0,117	1.067	1.07	10,60	0,417
ECP32 2S4 C	115/200/230/400 - 50	0,08	1.159	0.96	10,60	0,417
ECP32 1M4 C	115/200/230/400 - 50	0,059	1.275	0.96	10,60	0,417
ECP32 2M4 C	115/200/230/400 - 50	0,053	1.576	0.95	10,60	0,417
ECP32 1L4 C	115/200/230/400 - 50	0,039	1.668	0.87	11,35	0,442
ECP32 2L4 C	115/200/230/400 - 50	0,035	1.715	0.87	11,35	0,442
ECP34 1S4 C	115/200/230/400 - 50	0,033	2,392	1.43	15,28	0,410
ECP34 2S4 C	115/200/230/400 - 50	0,027	2,844	1.35	15,28	0,410
ECP34 1M4 C	115/200/230/400 - 50	0,020	3.008	1.35	15,28	0,410
ECP34 2M4 C	115/200/230/400 - 50	0,020	3.172	1.18	15,28	0,410
ECP34 1L4 C	115/200/230/400 - 50	0,014	3.467	1.05	15,28	0,410
ECP34 2L4 C	115/200/230/400 - 50	0,015	3.624	0.855	15,28	0,410

2.3.9 Overall dimensions

ECP 4C 4 Pole - Mounting form MD35

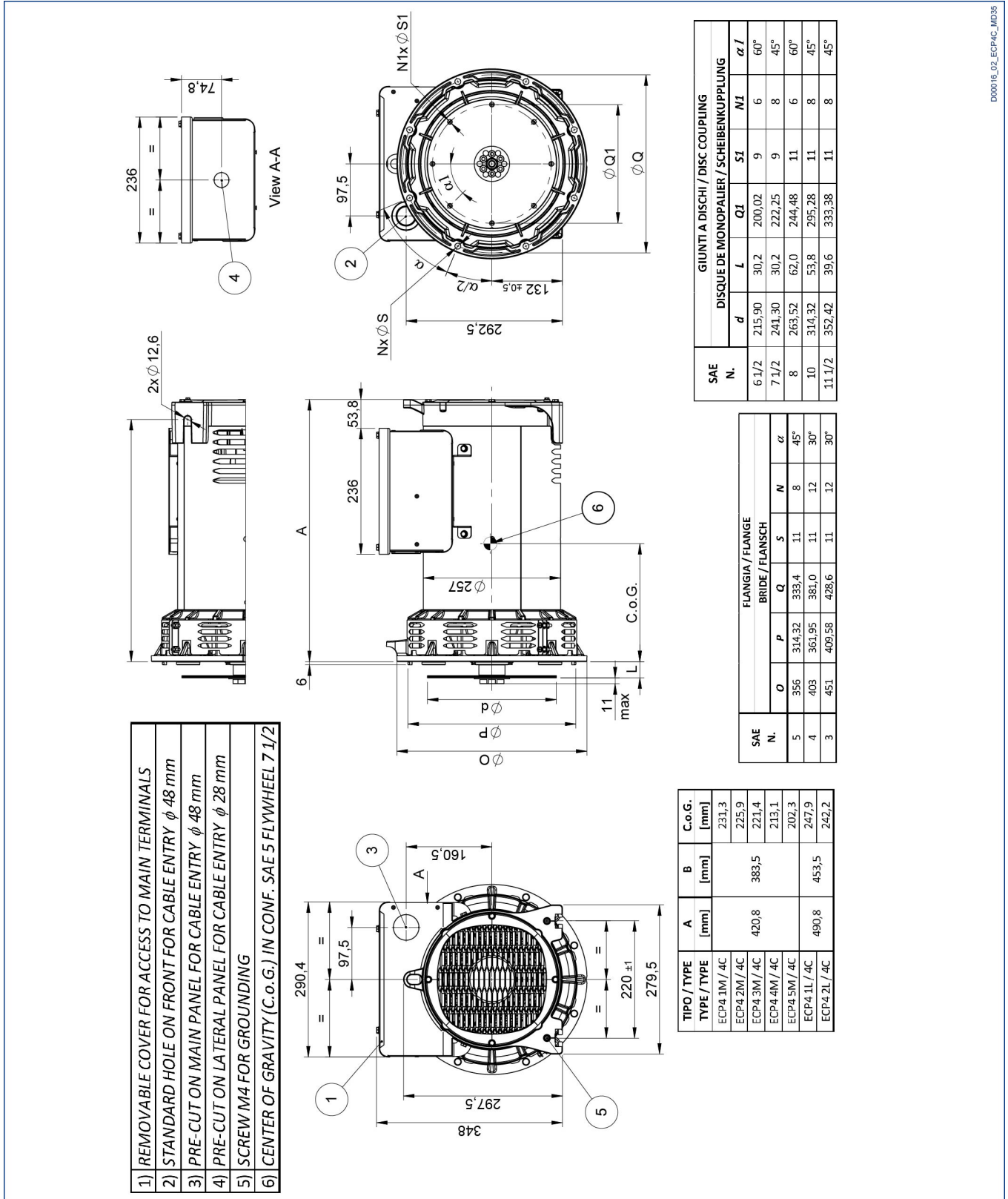

D00016_02_ECP4C_MD35

ECP 32C 4 Pole - Mounting form B3B14

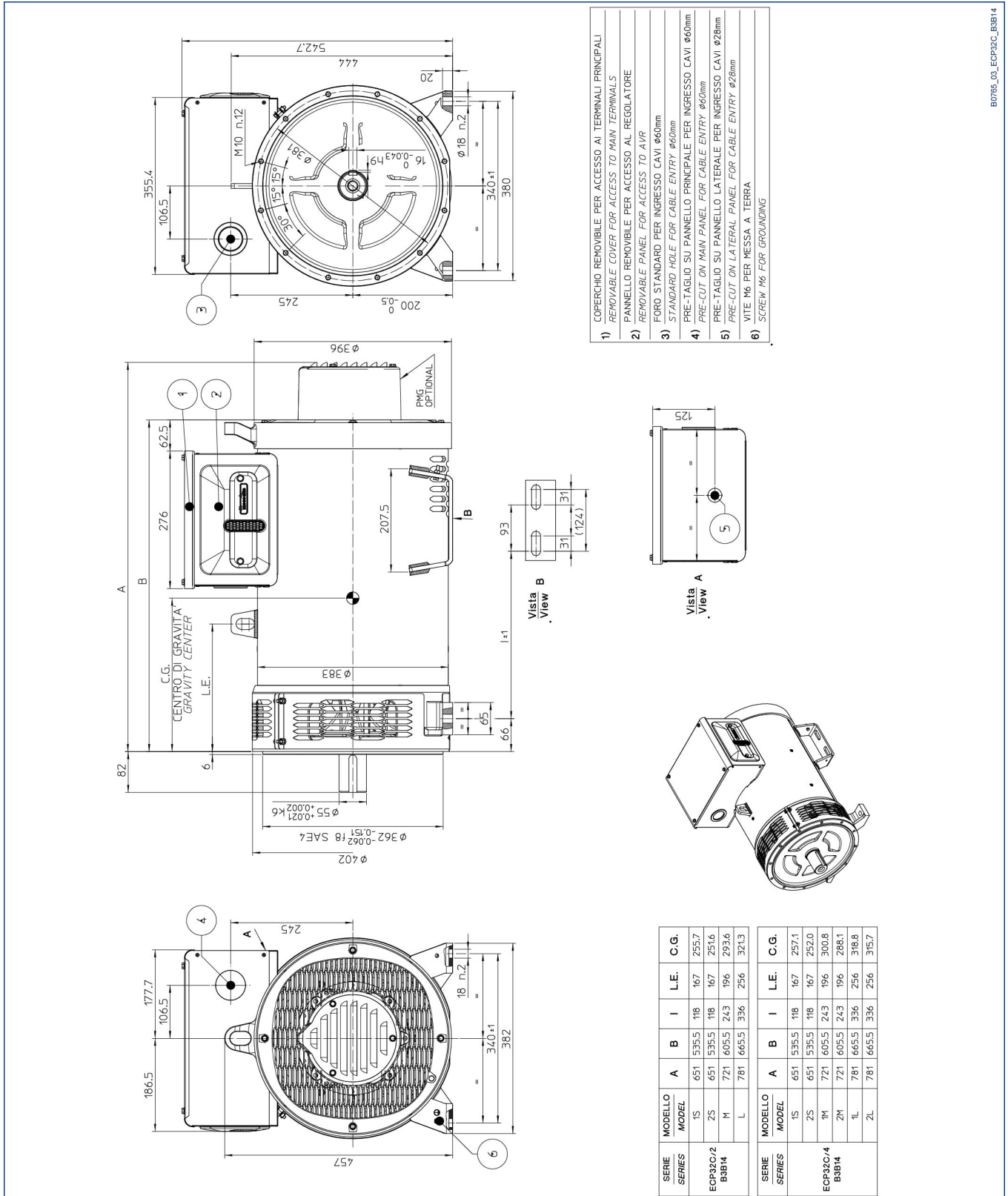

- 1) COPERCHIO REMOVIBILE PER ACCESSO AI TERMINALI PRINCIPALI
REMOVABLE COVER FOR ACCESS TO MAIN TERMINALS
- 2) PANNELLO REMOVIBILE PER ACCESSO AL REGOLATORE
REMOVABLE PANEL FOR ACCESS TO AVR
- 3) FORO STANDARD PER INGRESSO CAVI Ø60mm
STANDARD HOLE FOR CABLE ENTRY Ø60mm
- 4) PRE-TAGLIO SU PANNELLO PRINCIPALE PER INGRESSO CAVI Ø60mm
PRE-CUT ON MAIN PANEL FOR CABLE ENTRY Ø60mm
- 5) PRE-TAGLIO SU PANNELLO LATERALE PER INGRESSO CAVI Ø28mm
PRE-CUT ON LATERAL PANEL FOR CABLE ENTRY Ø28mm
- 6) VITE M6 PER MESSA A TERRA
SCREW M6 FOR GROUNDING

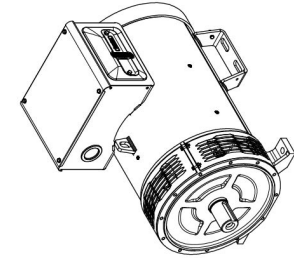

SERIE	MODELLO	A	B	I	L.E.	C.G.
ECP32C/2 B3B14	1S	651	535.5	118	167	255.7
	2S	651	535.5	118	167	251.6
	M	721	605.5	243	196	293.6
	L	781	665.5	336	256	321.3
SERIE	MODELLO	A	B	I	L.E.	C.G.
ECP32C/4 B3B14	1S	651	535.5	118	167	257.1
	2S	651	535.5	118	167	252.0
	M	721	605.5	243	196	300.8
	L	781	665.5	336	256	318.8
	2L	781	665.5	336	256	315.7

B0765_03_ECP32C_B3B14

2.3.10 Materials

The table below contains the approximate percentages of the materials used in Mecc Alte S.p.A's alternators.

Material	Percentage
Steel Parts	45%
Cast Iron Parts	20%
Copper Parts	20%
Aluminum Parts	10%
Plastic Parts	3%
Electronic parts	2%

2.4 Operating ambient requirements

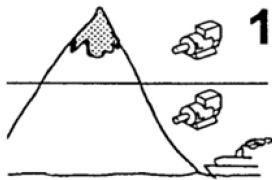

1000m

Max ambient temperature to guarantee the nominal power:

40°C

40°C

Max operating altitude to guarantee the nominal power:

Less than
1000 m.

dis_ECO_032-r00



dis_ECO_038-r00



Install the alternator in a well-aired room. Insufficient ventilation may cause overheating and malfunctioning of the alternator.



For the air volumes required see paragraph 2.3.5.

3 Safety

3.1 General Instructions

The alternator may be used only for the purpose for which it was designed and built.

Caution



The ECP series alternators comply with the Directive 2006/42 as amended, therefore they do not pose threats to the operators, if installed, used and serviced in accordance with the instructions provided by Mecc Alte and on condition that the safety devices are kept in perfect state of efficiency

Danger



Install the alternator only after having read and understood all the sections of this manual.

Danger



Do not operate it while under the influence of intoxicating agents that might delay reaction time such as, for instance, alcohol or drugs.

Danger



The alternator installation, operation and maintenance technicians must be adequately qualified specialists who know the characteristics of the alternators.

Warning



Adequate work clothing is recommended. Avoid wearing chains, bracelets, scarves and cumbersome clothing, long hair must be tied.

Warning



Do not neutralize, remove, alter or otherwise render ineffective any safety, protection or control device of the alternator.

Warning



Maintain the work areas and the routes defined for the installation of the alternator always free from materials and/or elements that may hinder the movement of or cause accidents to the operator.

Caution



The work area must always be adequately lit.

Caution



Keep the floor in the operating area always clean and dry to prevent the forklift truck from sliding sideways when in movement.

Danger



Never operate the alternator with wet hands and objects when it is energized.



Warning

Do not lean on and do not step onto the alternator.



Warning

At the end of each operation that involved removal of the safeguards, put them back and make sure that the correct positioning and efficiency are restored.



Danger

Keep the alternator at a safe distance from flammable materials.



Danger

The alternators, when working, release heat even to a high level based on the power being generated. Before touching it wait for the alternator to cool off.



Danger

Working alternators are noisy (see paragraph 2.3.3). Install the alternator in insulated rooms and wear earmuffs to operate it.

3.2 Alternator Safety devices

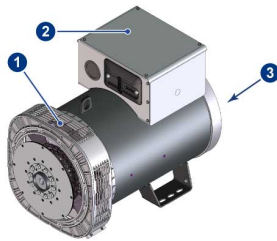

sk_ECP-C_031-00

The safety devices of the alternator are:

1. Protection screen on the front shield.
2. Cover of terminal box.
3. Rear cover.



Danger

During the operation of the alternator the safeguards must always be closed.

3.3 Safety tags



Caution

Do not remove under any circumstances the tags attached to the alternator.

The following safety tags are attached to the machine

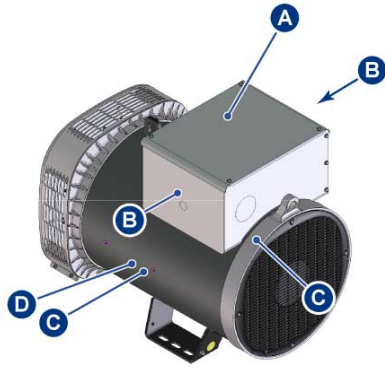

lay_ECP-C_004-00

Pos.	Label	Code	Description
A		XXX	Refer to instruction manual before removing covers
B		XXX	Danger!
C		XXX	Danger - Electricity!
D		XXX	Danger - Hot surface!



Caution

The labels must be replaced if they are worn out or cannot be read anymore.

3.4 Personal Protective Equipment



Caution

The staff in charge with the operation of the alternator must wear the personal protective equipment (PPE) indicated in the table below.

PPE	Operation
	Always wear
	Maintenance or lifting the alternator or its components.



Caution

The operator must observe the accident prevention regulations in force in the specific country where the alternator is used.



Caution

The PPE assigned may not be altered.

The manufacturer disclaims all responsibility for any potential damages caused to people by failure to use the PPE.

3.5 Residual risks

The alternator presents the following residual risks:



Danger

Burning risk. The working alternator may release heat even to a high level. Before touching the alternator wait for it to cool off.



Caution

Risk of crushing while lifting. Do not stand under the suspended load, do not come close to it, use adequate PPE.

4 Transportation, movement and storage.

The ECP series alternators are delivered by road on pallets, by sea in fumigated wood cases. Other shipment methods available on customer request.

The cases shipped by sea are covered with nylon to avoid salt infiltration that could compromise the correct operation of the alternator.

Any potential replacement parts are however shipped in cardboard packing that is disposed of according to the local regulations. Packing is always accompanied by a packing list.

Transportation of the packing to the installation place will be provided by the customer.



Upon delivery of the alternator check against the delivery note that there are no missing parts and/or damages; in case there are any, immediately inform the carrier, the insurance company and the reseller or Mecc Alte.

4.1 General Instructions



Warning

The instructions of this chapter must be strictly followed when lifting the alternator.



Warning

Use adequate, tested and certified lifting devices.



Warning

Lifting and transportation must be carried out by members of staff who were trained for this purpose.



Warning

To carry out any lifting, transportation and handling operation wear the PPE indicated by the regulations (see paragraph 3.4).



Warning

When lifting the alternator with the forklift truck keep its forks at the longest possible distance one from the other so as to prevent the alternator from falling or sliding off.

Always make sure that the devices and means for packing materials removal, the alternator and any disassembled part are suitable and undamaged.

4.2 Packing materials lifting and transportation



Danger

Pay attention during all transportation and movement operations. Do not stand under suspended loads.



Warning

Check the packing or the documentation attached to it for the weight to lift, the predefined anchor points and use suitable equipment for the lifting.

4.3 Unpacking



Unpack the alternator carefully without breaking/damaging the packing materials. Both the cases (equipped with metal hinges so that they may be folded) and the pallet must be returned to Mecc Alte.

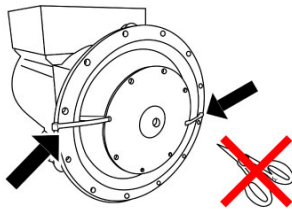

dis_ECO_042-r00

Once the single-bearing alternator is unpacked do not cut the tie strips of the rotor to prevent it from sliding.

4.4 How to dispose of the packing materials

Please recycle the packing materials in accordance with the applicable regulations in the country where the alternator is installed.

4.5 Alternator Movement



Unpacked alternators must always be handled hooking the eyebolts to a lifting device.



For the weight of the alternator see paragraph 2.3.4

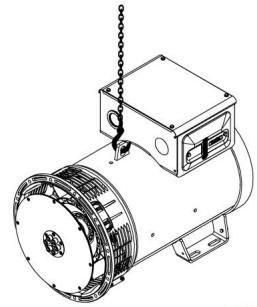

dis_ECP-C_033-00



Caution

Lift the alternator to a height not exceeding 30 cm.



Do not add any other load. The eyebolts are only designed for the lifting of the alternator. Do not use the alternator eyebolts to lift the fully assembled machine.



Danger

Once it is coupled to the drive motor, to lift the alternator you must follow the instructions provided by the manufacturer of the fully assembled machine.

4.6 Storage

In case of storage, the alternators, be them packed or not, must be stored in a cool, dry place away from vibrations and never exposed to the elements.



The bearings require special maintenance but it is advisable to turn the shaft around once or twice a month to prevent contact corrosion and grease hardening; before startup, where regular lubrication is required, you must also lubricate it.



After being stored for a long time or if there are obvious signs of humidity/condensation, check the insulation state.



Warning

The insulation test must be carried out by a qualified technician.



Warning

Before carrying out the test you must disconnect the voltage regulator.



If the result of the test is too low (less than 5 M Ω) (EN60204-1) you will have to dry the alternator by blowing 50-60 C° pressurized air into the air intakes and exhausts of the alternator.

5 Installation instructions / drive motor coupling

Warning



The final installer is in charge with assembling all the safeguards (disconnect switches, safeguards against direct and indirect contact, safeguards against overcurrent and overvoltage, emergency stop and so on) required to make the machine and the user system comply with the European and International Safety Regulations.



The installation and first startup operations of the fully assembled machine must be carried out by qualified personnel.

Danger



Working alternators are noisy (see paragraph 2.3.3). Install the alternator in insulated rooms and wear earmuffs to operate it.

5.1 Installation Setup



The alternator must be grounded before installation. Please ensure that the grounding system is effective and it complies with the directives of the country where the alternator will be installed.

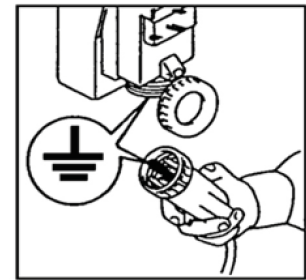

dis_ECO_034-r00

The alternator is designed and built to be installed in well-ventilated environments.



See paragraph 2.4.

Danger



Install the alternator in a ventilated room. Insufficient ventilation may cause overheating and malfunctioning of the alternator.

Please ensure that the base of the alternator and of the drive motor is calculated so as to support the weight of all potential stresses caused by the operation.

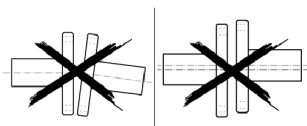

dis_ECO_049-r00

The installer is in charge with correctly coupling the alternator to the drive motor and all the other measures required to guarantee the correct operation of the alternator and to avoid anomalous stresses that might damage the alternator (such as vibrations, misalignments, various kinds of mechanical stresses).

5.2 Unpacking and disposal of packing materials

Danger



Pay attention during all transportation and movement operations.



Danger

Do not stand under suspended loads.



Carefully remove the packing.



Please recycle the packing materials.

5.3 Mechanical coupling

The coupling of the alternator to the drive motor must be carried out by the end user. It is carried out at his sole discretion, but it must:

- Be realized in accordance with the safety regulations in force.
- Ensure the ideal operating conditions for the alternator (air temperature below 40 °C and air vents not blocked).
- Ensure easy access for its verification and maintenance.
- Be assembled on a strong base able to hold the total weight of the alternator and the drive motor.
- Observe the assembly tolerances.

Control the correct fastening of the discs to the alternator rotor.



See paragraph 9.7



Imprecise alignment may cause vibrations and damages to the bearings.

Moreover, it is advisable to check the compatibility of the torsional characteristics of the motor / alternator (to be carried out by the customer).



Please see the related technical documentation.



In case of double-bearing alternators, ensure that the radial loads applied to the shaft protrusion do not exceed the admissible values.



See paragraph 2.3.2.

These values are calculated so as to prevent excessive shaft flexure. The load that may be supported by the bearings is statically and dynamically higher than the one supported by the shaft, however, the presence of excessive vibrations or adverse environmental conditions may reduce the bearing's life or lead to a lower maximum allowable load in proportion to the bearing's life.



During the assembly and disassembly stages of the net, make sure you hold it in position with your hands so as to prevent the elastic net from hitting the operator or anyone else nearby.



In case of single-bearing alternators, during the drive motor coupling stage make sure the rotor does not slip out by keeping the alternator in a horizontal position. Remove the rotor fastening system, if present.

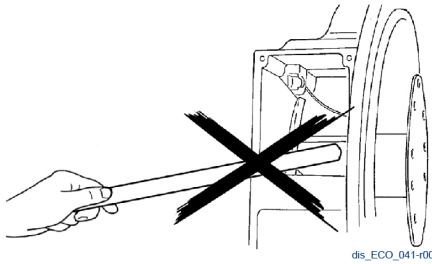

During the mechanical coupling procedures do not use the fan as a lever to turn the rotor.

5.3.1 Alternator Preparation

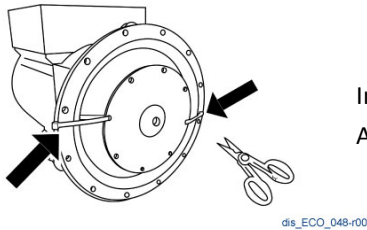

In the case of single-bearing alternators, remove the safety clamps from the rotor. After this operation, pay attention that the rotor does not slip out during handling.

5.3.2 Aligning the drive motor to the B3B14 alternator

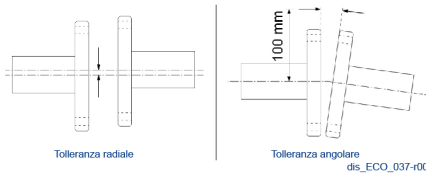

To ensure regular operation of the B3B14 construction type alternator you must align it to the drive motor in observance of the radial and angular tolerances between the two shafts of the drive motor - alternator.



Misalignment may cause damages to the shaft or to the bearing. For alignment tolerances see 2.3.6.

5.3.3 Aligning the drive motor to the MD35 alternator

The (MD35) single-bearing alternator needs a solid flat base in order for the alignment to be realized correctly.

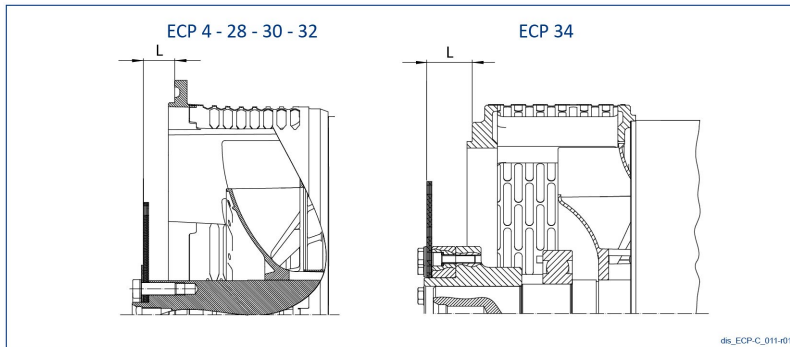

i Always check rigorously the accuracy of the L dimension.

i Errors on the L dimension may lead to high axial loads on the bearings and potential damages to the drive motor as well.

i For alignment tolerances see paragraph 2.3.7.

i The presence of flexures on the alternator coupling flange may cause high vibrations and in the worst cases even mechanical breaks.

5.3.4 Thermal Expansion Compensation

The compensation of thermal expansion is particularly important for the single-bearing generators inasmuch as they are connected directly to the motor and a perfect alignment is essential so as to guarantee the intended useful life of the bearings. In case of double-bearing generators the importance of this aspect depends on the type of motor-generator coupling.

Operating temperatures have a significant impact on the alignment tolerances and must be taken into consideration. Because of them, actually, during the operation, the alternator shaft may be in a different position than its position when powered off.

A compensation of the alignment may therefore be required and it depends on the operating temperatures, on the coupling type, on the distance between the two machines and so on.

The two more important types of thermal expansion to take into consideration are:

- Vertical thermal expansion
- Axial thermal expansion

Vertical thermal expansion

This thermal expansion may cause variations of the radial tolerance value and it may be calculated using the following formula:

$$\Delta H = \alpha \times \Delta T \times H$$

ΔH = Variation of height.

α = Coefficient of thermal expansion (value $\alpha = 10 \times 10^{-6} \text{ K}^{-1}$ may be used).

ΔT = Difference between the alignment temperature and the operating temperature.

H = Axle height.

Axial thermal expansion

The axial thermal expansion value may diminish the axial tolerance between the two shafts.

It is a very important value inasmuch as, when the whole system reaches a uniform temperature, a very narrow non-operating tolerance may lead to an axial force that may burden the bearings damaging them or causing them to break.

The following formula may be used to calculate it:

$$\Delta L = \alpha \times \Delta T \times L$$

ΔL = Variation of the shaft length.

α = Coefficient of thermal expansion (value $\alpha = 10 \times 10^{-6} \text{ K}^{-1}$ may be used).

ΔT = Difference between the alignment temperature and the operating temperature.

L = Shaft length, calculated between the bearing and the drive motor coupling discs.

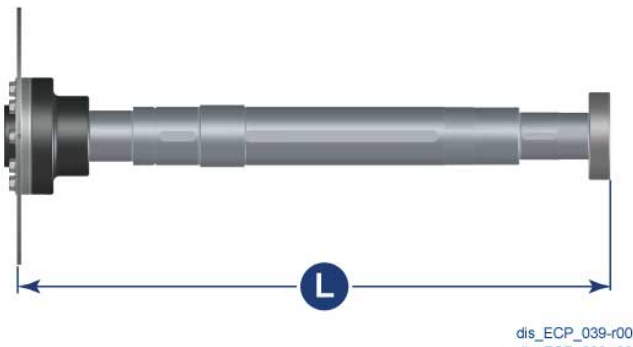

The variation of the axial tolerance is calculated by relating the axial thermal expansion of the alternator to that of the motor.

6 Electrical connection



The operation must be carried out by an electrical maintenance technician.

The electrical connection shall be provided by the end user and it is carried out at his sole discretion

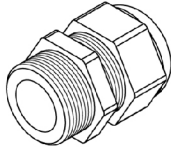

dis_GEN_003-r00

For the entry into the terminal box it is advisable to use cable glands and cable reliefs in compliance with the specifications of the user country.



See "12 terminal connections" table in this chapter.

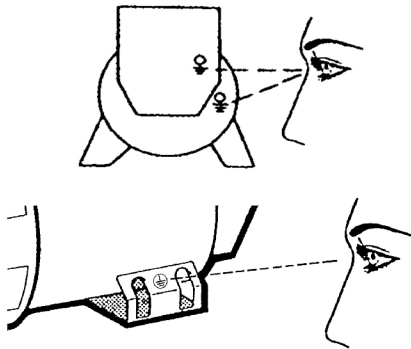

dis_GEN_004-r00

The alternators must always be grounded with a grounding conductor of an appropriate size. Use one of the two dedicated terminals (internal/external).

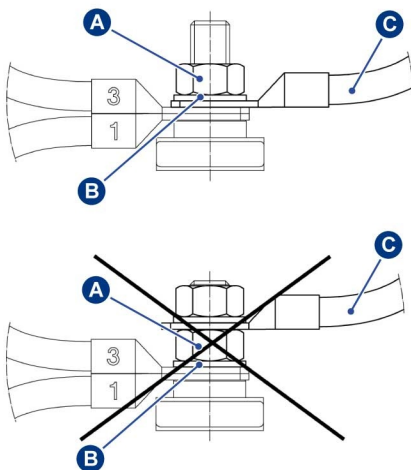

dis_GEN_005-r00

For the electrical connection use adequate cables, sized on the basis of the alternator power. Make the connections to the terminals as shown in the figure.

- A) Hexagon nut
- B) Plain washer
- C) User cable



See paragraph 6.1.

Once the connection was made check the terminal tightening torques that must comply with the instructions given in chapter 9.8

When the connection is finished reassemble the cover of the terminal box.



The user power cables must be wired and supported adequately so as not to cause mechanical stress on the terminal block of the alternator.

Phase rotation and sequence



U1 V1 W1
| | |
L1 L2 L3



U1 V1 W1
| | |
L3 L2 L1

dis_ECP-C_044-r00

All the fans of the ECP alternators are designed to rotate bidirectionally.

Clockwise rotation, seen from the coupling side: the order of the outgoing phases is L1, L2 , L3.

Anticlockwise rotation, seen from the coupling side: the order of the outgoing phases is L3, L2 , L1 (the order is reversed).

Winding connection modalities

The alternators are manufactured with 12 standard outgoing cables in order to allow different voltage output, for instance, at 50 Hz, 115 V ($\Delta\Delta$) / 200 V (YY) / 230 V (Δ) / 400 V (Y). To pass from a connection to another follow the diagrams shown in the "12 wires connection" table on the next page.

12 wires connection													
Connection		Winding T0405S3 (***)											
		50Hz	L - L	380	400	415	440	50Hz	L - N	220	230	240	254
Series star		50Hz	L - L	380	400	415	440	60Hz	L - L	460	480	500	530
		50Hz	L - N	220	230	240	254	60Hz	L - N	265	277	290	305
		60Hz	L - L	460	480	500	530	60Hz	L - N	265	277	290	305
		60Hz	L - N	265	277	290	305						
Parallel star		50Hz	L - L	190	200	208	220	50Hz	L - N	110	115	120	127
		50Hz	L - N	110	115	120	127	60Hz	L - L	230	240	250	265
		60Hz	L - L	230	240	250	265	60Hz	L - N	133	138	145	152
		60Hz	L - N	133	138	145	152						
Series delta (*)		50Hz	L - L	220	230	240	254	50Hz	L - M	110	115	120	127
		50Hz	L - M	110	115	120	127	60Hz	L - L	265	277	290	305
		60Hz	L - L	265	277	290	305	60Hz	L - M	133	138	145	152
		60Hz	L - M	133	138	145	152						
Parallel delta (*)		50Hz	L - L	110	115	120	127	60Hz	L - L	133	138	145	152
		60Hz	L - L	133	138	145	152						
Three phase Zig-Zag (**)		50Hz	L - L	330	346	360	380	50Hz	L - N	190	200	208	220
		50Hz	L - N	190	200	208	220	60Hz	L - L	400	415	430	460
		60Hz	L - L	400	415	430	460	60Hz	L - N	230	240	250	265
		60Hz	L - N	230	240	250	265						
Single phase parallel zig-zag (*)		50Hz	L - L	220	230	240	254	50Hz	L - M	110	115	120	127
		50Hz	L - M	110	115	120	127	60Hz	L - L	265	277	290	305
		60Hz	L - L	265	277	290	305	60Hz	L - M	133	138	145	152
		60Hz	L - M	133	138	145	152						
Single phase double delta (*)		50Hz	L - L	220	230	240	254	50Hz	L - M	110	115	120	127
		50Hz	L - M	110	115	120	127	60Hz	L - L	265	277	290	305
		60Hz	L - L	265	277	290	305	60Hz	L - M	133	138	145	152
		60Hz	L - M	133	138	145	152						

tab_ECP-C_012-r00



* In case of single-phase loads it is important to remember not to exceed the phase current.

** In the interconnected star connection, the power must be reduced to 0.866 times its nominal value.

*** The highlighted cells represent the nominal values. The other voltage values can be obtained by adjusting the VOLT potentiometer. Voltage variations in relation with the nominal value may though lead to a derating of the machine. For the powers please consult the technical documentation available on www.meccalte.com.



The machine supplied to operate at 50Hz may also work at 60Hz (or vice versa). To obtain the variation you simply adjust the potentiometer to the new nominal voltage value. When passing from 50Hz to 60Hz power may increase by 20% (unvaried current) if the voltage increases by 20%. For alternators specifically built for a 60Hz frequency when passing to 50Hz the voltage and the power must be reduced by 20% in relation to the values referring to 60Hz.

6.1 Terminal board configurations

6.1.1 ECP 4 regulation box

A

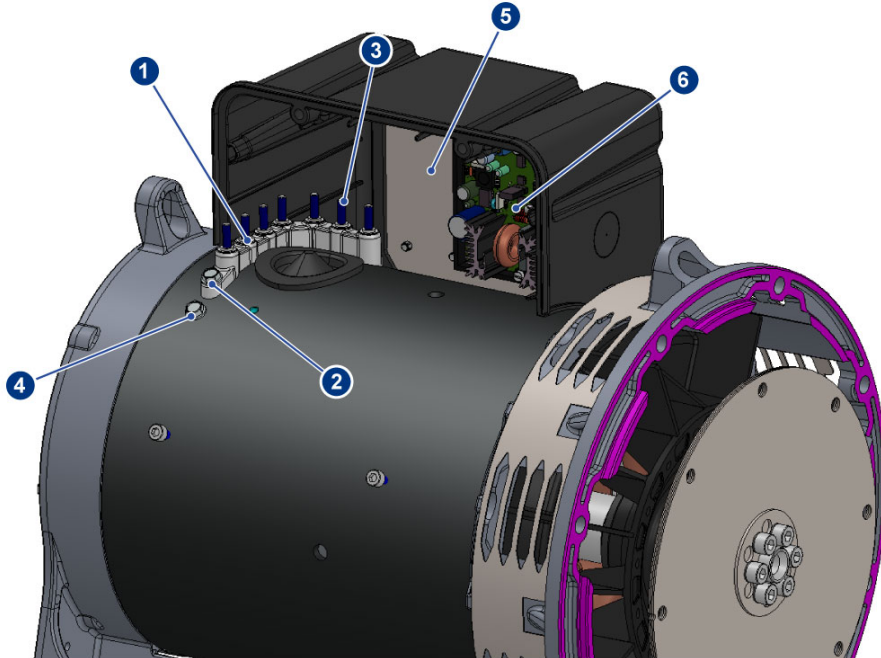

B

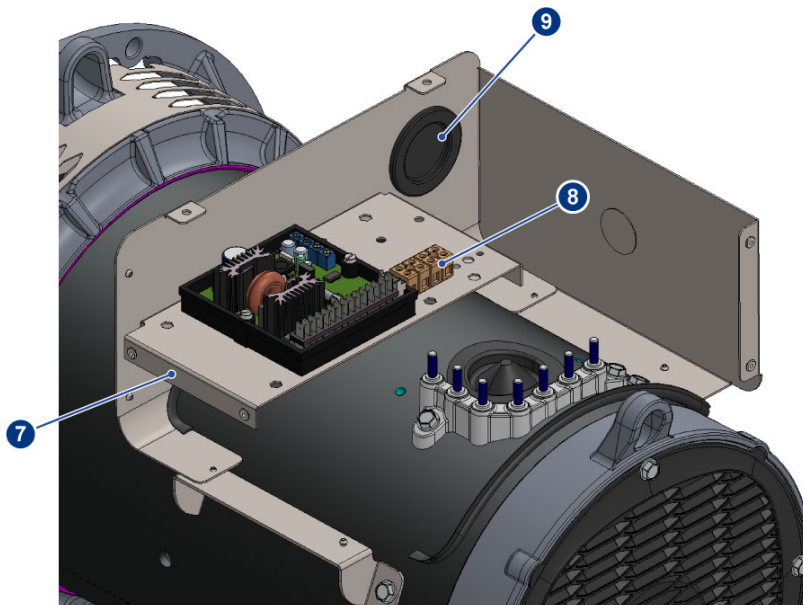

ds_ECP-C_010-r00

A: Standard B: Optionals

Pos.	Components	Pos.	Components
------	------------	------	------------

1	M5 7-pin terminal board
2	TE Self-forming screw M6x16 (n.2)
	Tightening torque 9Nm
3	Tightening torque 5Nm
4	Self-forming TE screw M6x16
	Tightening torque 9Nm
5	Regulator holding panel
	TE M6x16 screw(n.4)
	Tightening torque 9Nm
	TE M6 UNI 5587 nut (n.4)

6	Regulator
	TC M4x20 screw (n.2)
	Tightening torque 1.5Nm
	Toothed washer Ø4 (n.4)
7	TE M4 UNI 5587 nut (n.2)
	Regulator holding panel
8	MK-3/12 KRG terminal
9	DG36 plug

6.1.2 ECP 28 / ECP 30 regulation box

A

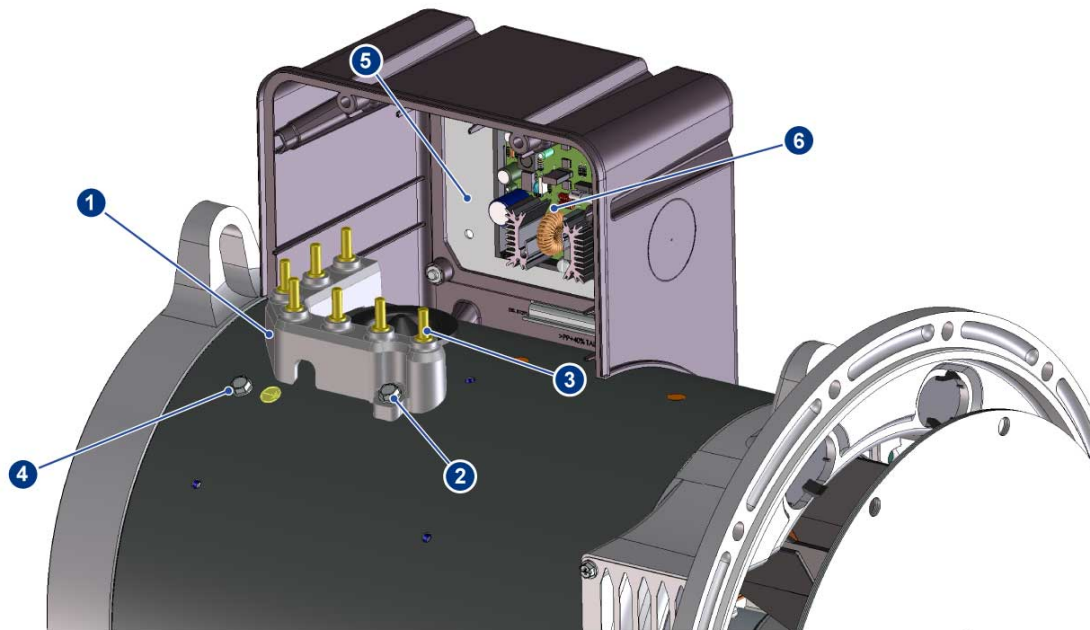

B

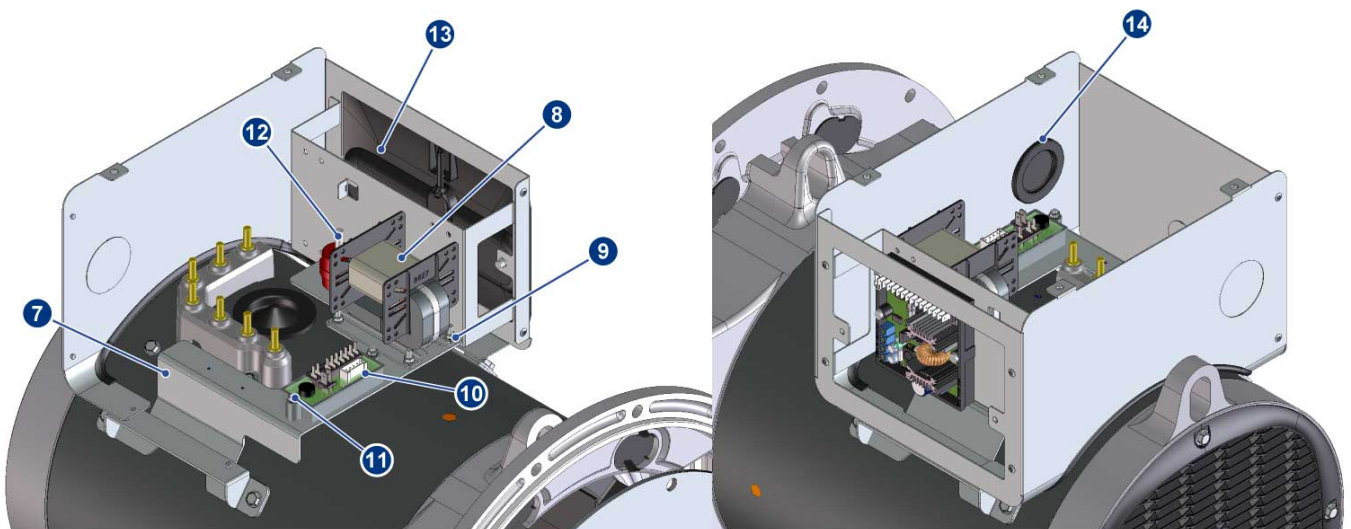

ds_ECP-C_014-r00

A: Standard B: Optionals

Pos.	Components
1	M6 7-pin terminal board
2	TE Self-forming screw M6x16 (n.2)
	Tightening torque 9Nm
3	Tightening torque Nm
4	Self-forming TE screw M6x25
	Tightening torque 9Nm
5	Regulator holding panel
	TE M6x16 screw(n.4)
	Tightening torque 9Nm
	TE M6 UNI 5587 nut (n.4)
6	Regulator
	TC M4x20 screw (n.2)
	Tightening torque 1.5Nm
	Toothed washer Ø4 (n.4)
	TE M4 UNI 5587 nut (n.2)
7	Regulator holding panel
8	Parallel Device PD500
10	PD-I Interface

Pos.	Components
9	TC M4x10 screw (n.4)
	Tightening torque 1.5Nm
	Flat washer Ø4 (n.4)
	Toothed washer Ø4 (n.4)
10	PD-I Interface
11	TC M4x20 screw (n.2)
	Tightening torque 1.5Nm
	Toothed washer Ø4 (n.4)
12	DB30P M6 isolator
	TE M6x10 screw (n.1)
	Tightening torque 7Nm
	Flat washer Ø6 (n.1)
13	Toothed washer Ø6 (n.1)
	Regulator plug with screwdriver
13	TE Self-forming screw M6x16 (n.2)
	TE M4 UNI 5587 nut (n.2)
14	DG36 plug

6.1.3 ECP 32 regulation box

A

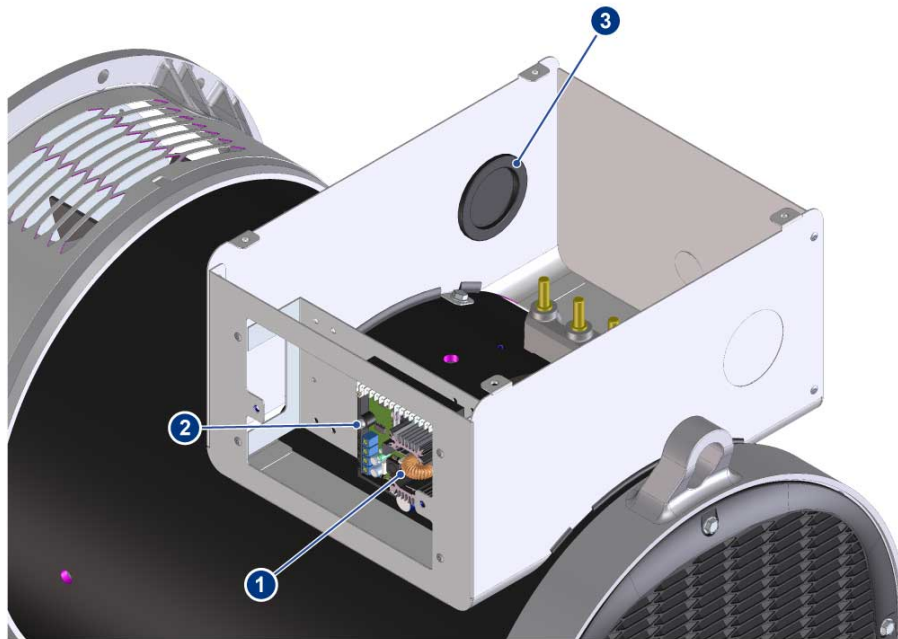

B

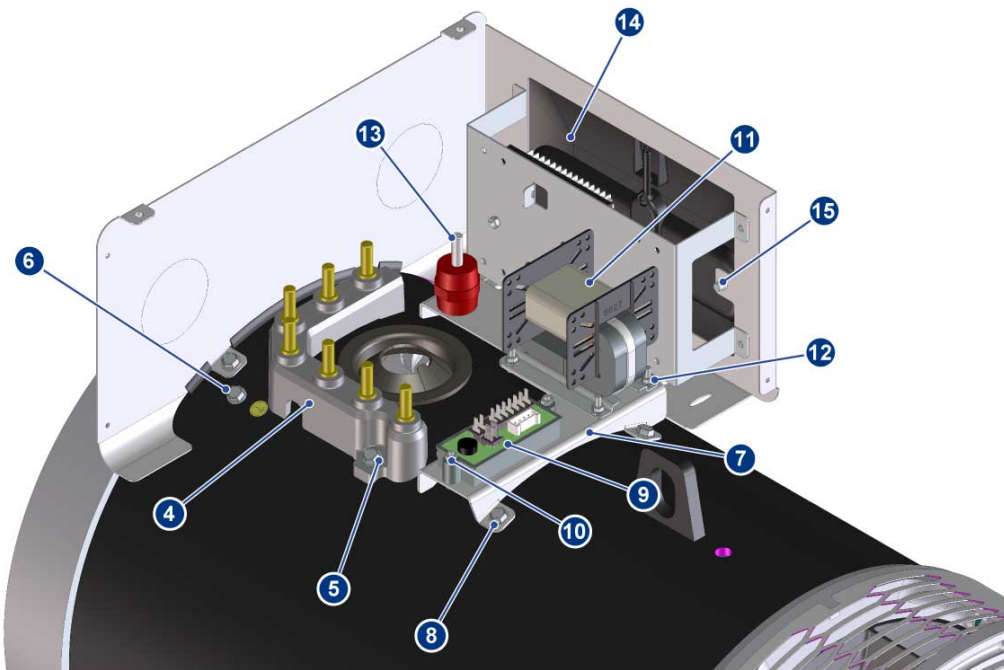

ds_ECP-C_015-r00

A: Standard B: Optionals

Pos.	Components
1	Regulator
2	TC M4x20 screw (n.2)
	Tightening torque 1.5Nm
	Toothed washer Ø4 (n.4)
	TE M4 UNI 5587 nut (n.2)
3	DG48 plug
4	M6 7-pin terminal board
5	Self-forming TE M6x20 screw (n.2)
	Tightening torque 6Nm
6	TE Self-forming screw M6x16
	Tightening torque 9Nm
7	Regulator holding panel
8	TE Self-forming screw M6x16 (n.4)
	Tightening torque 9Nm
9	PD-I Interface
10	TC M4x20 screw (n.2)
	Tightening torque 1.5Nm
	Toothed washer Ø4 (n.4)

Pos.	Components
11	PD500 parallel device
12	TC M4x10 screw (n.4)
	Tightening torque 1.5Nm
	Flat washer Ø4 (n.4)
	Toothed washer Ø4 (n.4)
13	DB30P M6 isolator
	TE M6x10 screw (n.1)
	Tightening torque 7Nm
	Flat washer Ø6 (n.1)
14	Regulator plug with screwdriver
	Toothed washer Ø6 (n.1)
15	TE Self-forming screw M6x16 (n.2)
	Tightening torque 6Nm

6.1.4 ECP 34 regulation box

A

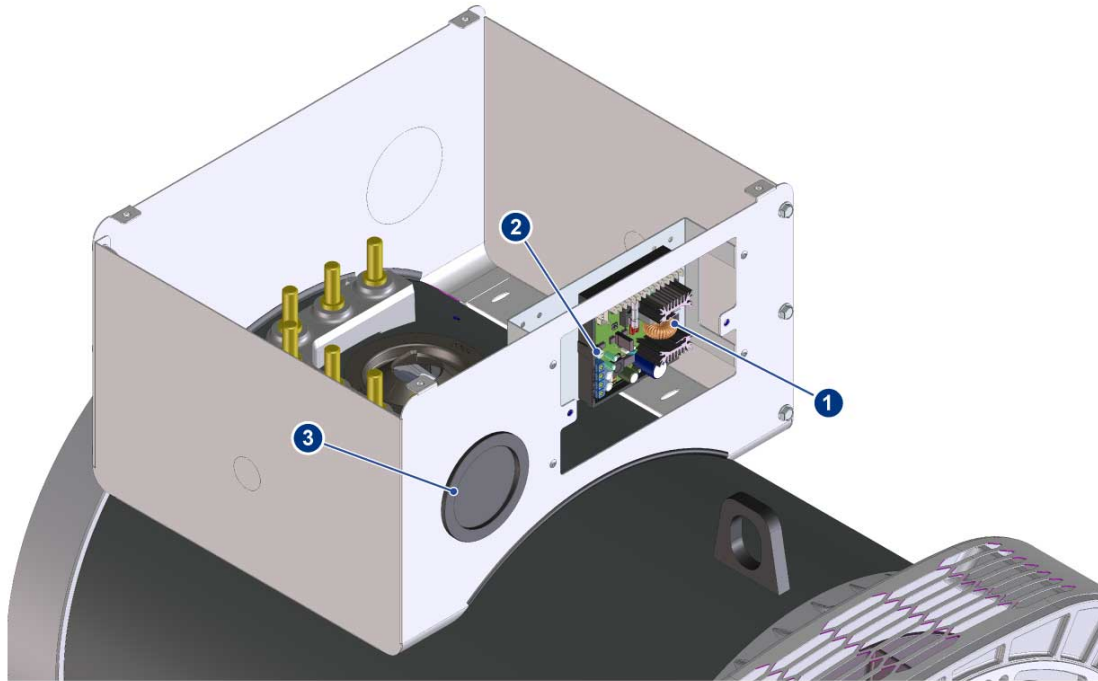

B

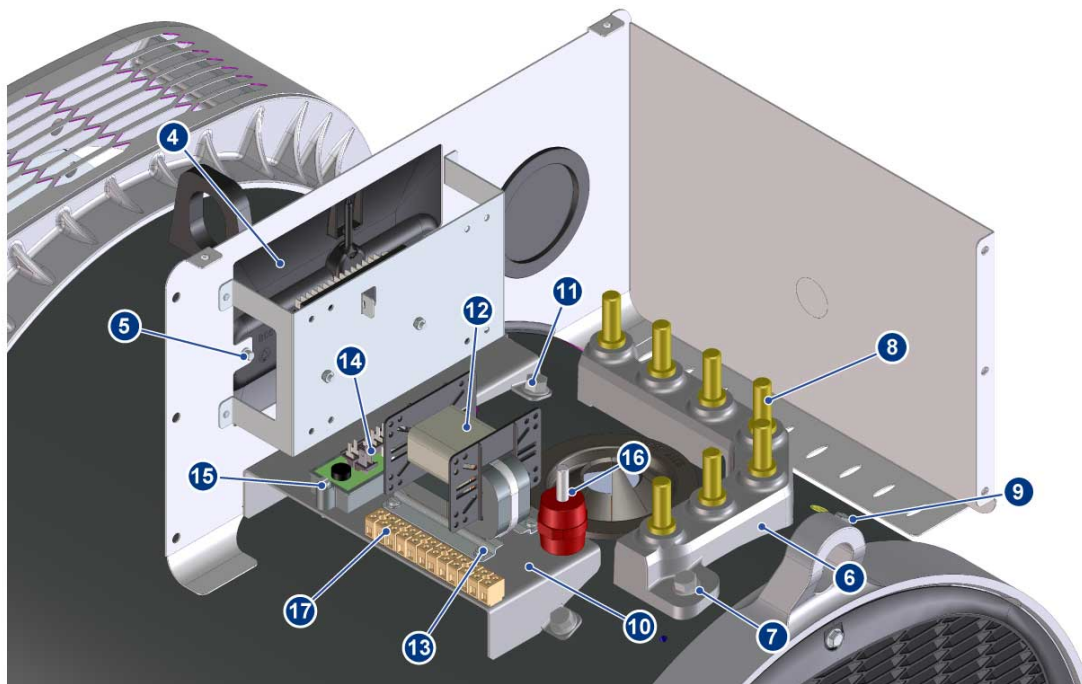

ds_ECP-C_016-r00

A: Standard B: Optionals

Pos.	Components
1	Regulator
2	TC M4x20 screw (n.2)
	Tightening torque 1.5Nm
	Toothed washer Ø4 (n.4)
	TE M4 UNI 5587 nut (n.2)
3	DG69 plug
4	Regulator plug with screwdriver
5	TE Self-forming screw M6x10 (n.2)
	Tightening torque 9Nm
6	M12 7-pin terminal board
7	TE Self-forming screw M8x20 (n.2)
	Tightening torque 21Nm
8	Tightening torque 42Nm
9	TE Self-forming screw M6x16
	Tightening torque 9Nm
10	Components holding panel
11	TE Self-forming screw M8x20 (n.2)
	Tightening torque 21Nm

Pos.	Components
12	PD500 parallel device
13	TC M4x10 screw (n.4)
	Tightening torque 1.5Nm
	Flat washer Ø4 (n.4)
	Toothed washer Ø4 (n.4)
14	PD-I Interface
15	TC M4x20 screw (n.2)
	Tightening torque 1.5Nm
	Toothed washer Ø4 (n.4)
16	DB3OP M6 isolator
	TE M6x10 screw (n.1)
	Tightening torque 7Nm
	Flat washer Ø6 (n.1)
17	Toothed washer Ø6 (n.1)
	MK-3/12 KRG terminal
	TC M3x16 screw (n.2)
	Tightening torque 0.5Nm
	Toothed washer Ø3 (n.8)

6.2 Parallel connection of alternators

In case you want the alternators to operate in parallel you need to use a device to ensure equal droop of output voltages. The parallel transformer is manufactured with a preset voltage drop of 4% at full load when the power factor is 0.

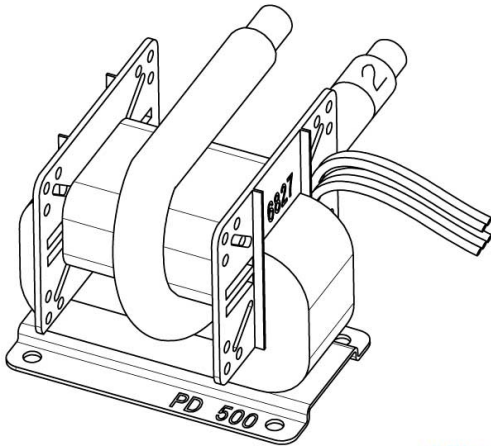

dis_ECO_051-r00

The device is supplied on request or it can be assembled by the customer. After having assembled the device you need to check the voltage drop; for further information please refer to the technical guide for parallel operation.

6.2.1 Installation of a parallel device

- Refer to mounting instructions "Retrofitting PD500 Procedure"
- Connect the power coil windings in series with the phase following the instructions

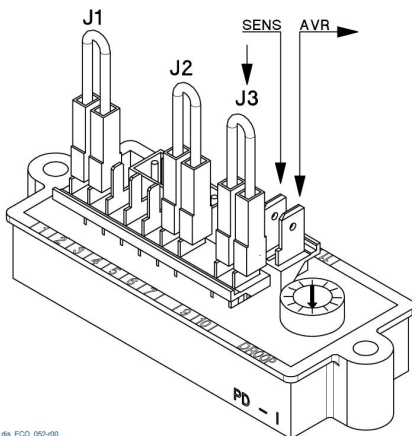

dis_ECO_052-r00

- i** For the number of coil turns needed on the transformer please see the drawing table A9865 inside the procedure
- Once received and installed the parallel device, it is important to check, based on the nominal data of the alternator and the adopted reference type, the jumpers J1 and J2 are wired to the correct fastons, according to drawing table A9865, inside the procedure. Also verify that the droop trimmer on the PD-I is positioned at the center.
- Connect the sensing of the alternator to the PD-I module and connect the PD-I module to the sensing terminal of the regulator, following step by step the instructions on the procedure

➔ See chapter 12.

To enable the paralleling device remove the jumper J3 between terminal 9 and 10 of the PD-I (see figures beside and wiring diagrams).



Warning

For alternators running in parallel to the grid the user must integrate the generation system with adequate protections.



Warning

For these applications it is fundamental to provide protection against the ample excitation variations or an excitation loss relay to avoid serious damages to the alternator.

After having made all the electrical connections and only after having closed the terminal box you may carry out the initial startup test on the system.

Check the no load voltage of the alternator and if necessary act on the electronic regulator VOLT trimmer to move back to the nominal value.

7 Startup Instructions

i This paragraph only reports the instructions for the initial startup of the alternator. You may find further instructions in the manual of the fully assembled machine.



Warning

The startup, operation and stop maneuvers must be carried out by adequately qualified personnel who has read and understood the safety and technical specifications indicated in this manual.



The tools for system startup, operation and stop shall be provided by the installer.



Check the alignment on the fully assembled machine. See paragraph 5.3.2.

- Check the fastening of the machine to the base with the related tightening torques and the robustness of the base.



Check the tightening torques of the terminal connections and their positioning. See paragraph 9.8.

Before the startup of the fully assembled machine you must make sure that:

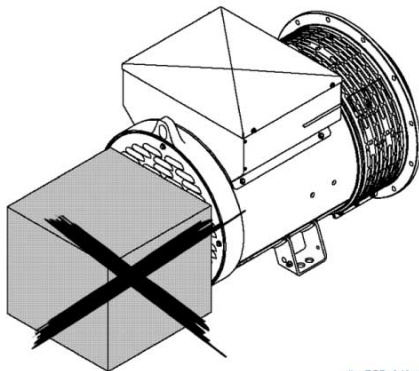

- The cooling air intake and exhaust vents are always unobstructed. It is recommended to keep a minimum distance of 20 cm free. For the cooling air volumes required see paragraph 2.3.5.
- The intake side is away from heat sources. However, if not specifically agreed, the temperature of the cooling air must be equal to the room temperature and anyway lower than 40 °C. The alternator may operate at higher temperatures with an appropriate derating.



During the initial startup that must be carried out at lower speed, the installer will have to make sure there are no anomalous noises. In case of anomalous noises stop the system immediately and make adjustments to improve the mechanical coupling.

The rotors of the Mecc Alte alternators and the alternators themselves comply with the regulations (see paragraph 1.5). This means that the vibrations generated by the Mecc Alte alternators are very limited and compliant with the regulations. Potential excessive vibrations are ascribable to the drive motor or to an erroneous motor-alternator coupling and they may cause damages or even breaks to the bearings.



The installer is responsible for following the regulations when assessing and measuring the vibrations on the fully assembled machine (see paragraph 1.5).

After the initial startup

After the initial startup of the fully assembled machine it is necessary to carry out the following verifications:

- Make sure everything works correctly.
- Monitor the vibration level and potential high temperatures of the windings and of the bearings.



In case the alternator, during operation, goes into protection mode for anomalous voltage, troubleshoot the fault before initiating another startup.



See "*Problems, causes and solutions*" chapter 11.

8 Electronic regulators

8.1 DSR Digital Regulator



The operation must be carried out by an electrical maintenance technician.



For further details on the regulators please refer to the specific manual.

Danger



Check with the alternator on.

Carefully perform the test, use adequate PPE such as for instance insulating gloves.



Voltage testing is performed off-load with the alternator running at nominal frequency. To obtain voltage regulation use the VOLT potentiometer of the electronic regulator.

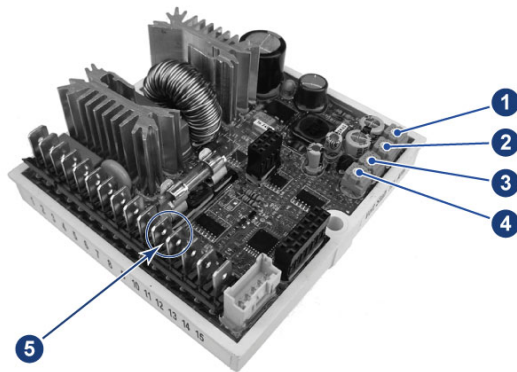

dis_ECO_019-r00

1. Regulation of overload protection (AMP).
2. Regulation of low frequency protection (Hz).
3. Regulation of stability (STAB).
4. Regulation of voltage (VOLT).
5. Terminals 10 and 11 for remote regulation of voltage.

Self-regulation is achieved through the DSR digital regulator that guarantees, under static conditions, a $\pm 1\%$ voltage accuracy with any power factor and with a speed variation ranging from -5% to $+20\%$.

Remote Regulation

To achieve remote regulation insert a $10K\Omega$ potentiometer in the dedicated terminals 10-11.

8.1.1 Stability Adjustment

The alternators are part of a system that can be outlined as a motor + alternator. The alternator may therefore exhibit instabilities of the rotation regime and of the voltage due to the irregular operation of the motor it is connected to.

There is a potentiometer dedicated to the adjustment of this stability (STAB potentiometer), because the alternator voltage and motor speed regulation systems may go into conflict, causing both speed and voltage oscillations.

It is important to stress that Mecc Alte's alternators are tested using an electric motor, not a heat engine. Therefore, STAB adjustment is set correctly for the alternator driven by an electric motor.

General instructions to follow in case of instability problems:

1. Check the STAB potentiometer setting and make sure it corresponds to the settings reported in the tables below.
2. If there is no correspondence, reset the potentiometer to the value indicated in the table below; in case of missing information position in the middle.
3. If the problem persists, rotate the potentiometer anticlockwise a notch and repeat the test.
4. If no differences are noticed or the differences are minimal, rotate another notch anticlockwise; continue this procedure until the problem is solved.
5. If by rotating the potentiometer anticlockwise, the voltage instability increases, set the potentiometer as indicated at point 2. Rotate the potentiometer clockwise a notch and repeat the test
6. If there are no changes or they are minimal, rotate another notch clockwise and repeat the test.
7. Continue this procedure until the problem is solved.
8. If after these steps the problem is still not solved, you may need to adjust the stability (gain) of the motor speed regulation system. If this does not solve the problem either, try to change the stability software parameters of the voltage regulator. See the dedicated manual.

DSR STAB TRIMMER					
Alternator		Nominal frequency = 50 Hz		Nominal frequency = 60 Hz	
Model	Pole	S [kVA]	STAB Position [tag]	S [kVA]	STAB Position [tag]
ECP4-1M/4 C (*)	4	6,5	-	7,8	-
ECP4-2M/4 C (*)	4	8	-	9,6	-
ECP4-3M/4 C (*)	4	10	-	12	-
ECP4-4M/4 C (*)	4	12,5	-	15	-
ECP4-5M/4 C (*)	4	15	-	18	-
ECP4-1L/4 C (*)	4	18	-	22	-
ECP4-2L/4 C (*)	4	20	-	24	-
ECP28-1VS/4 C (*)	4	7,5	5	9	4
ECP28-2VS/4 C (*)	4	10	4	12	4
ECP28-1S/4 C (*)	4	12,5	5 ½	15	5
ECP28-2S/4 C (*)	4	15	-	18	-
ECP28-3S/4 C (*)	4	17.5	6	21	5 ½
ECP28-M/4 C (*)	4	20	5 ½	24	5
ECP28-L/4 C (*)	4	25	7	30	5
ECP28-VL/4 C (*)	4	30	7	36	6
ECP30-1M/4 C (*)	4	20	-	24	-
ECP30-2M/4 C (*)	4	25	-	30	-
ECP30-3M/4 C (*)	4	30	-	36	-
ECP30-1L/4 C (*)	4	35	-	42	-
ECP30-2L/4 C (*)	4	40	-	48	-
ECP32-1S/4 C (*)	4	37.5	5 ½	45	4 ½
ECP32-2S/4 C (*)	4	45	6	54	6
ECP32-1M/4 C (*)	4	50	7 ½	60	4
ECP32-2M/4 C (*)	4	62.5	8	75	5 ½
ECP32-1L/4 C (*)	4	75	8 ½	90	5 ½
ECP32-2L/4 C (*)	4	82.5	-	100	-
ECP34-1S/4 C (*)	4	87.5	7 ½	105	7
ECP34-2S/4 C (*)	4	100	6 ½	120	6 ½
ECP34-1M/4 C (*)	4	125	-	150	-
ECP34-2M/4 C (*)	4	135	-	162	-
ECP34-1L/4 C (*)	4	150	8 ½	180	8
ECP34-2L/4 C (*)	4	165	-	198	-

* DSR: P[11] = 4, P[12] = 3, P[13] = 16384, quadratic function with integral gain.

** DSR/A: P[11] = 5, P[12] = 1, P[13] = 26624, linear function with integral gain

8.1.2 Protections

To avoid anomalous and dangerous operation of the alternator, the DSR digital regulator is equipped with a low speed protection and an overload protection.

Low speed protection

Its intervention is instantaneous and it causes the reduction of the alternator voltage when the frequency drops by 4 ± 1 % under the nominal frequency.

The intervention threshold is set using the "Hz" potentiometer.

Overload protection

A dedicated circuit compares the partialized excitation voltage. If the preset value for this voltage (a value corresponding with a load current value equal to 1.1 times the current indicated on the alternator tag) is exceeded for more than 20 seconds, the regulator steps in lowering the alternator voltage and subsequently limiting the current within a safe value range.

The delay is expressly introduced to allow the motors that normally start in 5÷10 seconds to pick-up. This intervention threshold may be adjusted using the "AMP" potentiometer.

Causes that lead to protection intervention.

Instantaneous protection intervention for low speed	1 - Speed reduced by 4 ± 1 % as compared to the rated data.
Delayed protection intervention for overload	2 - Overload of 10% as compared to the rated data.
	3 - Power factor ($\cos \phi$) lower than the rated data.
	4 - Environmental temperature above 50°C.
Intervention of both protections	5 - Combination of factor 1 and factors 2, 3, 4.

In case both protections intervene, the voltage supplied by the alternator will drop to a value that depends on the size of the fault.

Voltage will be automatically restored to its nominal value when the fault is solved.

8.1.3 Inputs and Outputs: technical specifications

TABLE 1 CONNECTOR CN 1				
Term.(*)	Name	Function	Specifications	Notes
1	Exc-	Excitation	Continuous Rating: 5 Adc max Transitory Rating: 12 Adc at peak	
2	Aux / Exc+			
3	Aux / Exc+	Power	Frequency: from 12Hz to 72Hz Range: 40 Vac - 270 Vac	
9	Aux / Neutral			
4	F_Phase	Sensing	Range: 140 Vac - 280 Vac Burden: <1VA	Measurement of average value (rectified) or actual effective value for voltage adjustment
5	F_Phase			
6	H_Phase		Range: 70 Vac - 140 Vac Burden: <1VA	
7	H_Phase			
8	Aux / Neutral			
10	Vext / Pext	Input for remote voltage control	Type: Not insulated Range: 0 - 2,5 Vdc or 10 K Potentiometer Adjustment: from - 14% to + 14% (***) Burden: 0-2 mA (sink) Max length: 30m (**)	Tolerates voltages from -5V to +5V but for values exceeding the range it is automatically disabled
11	Common			
12	50 / 60 Hz	50/60Hz Jumper input	Type: Not insulated Max length: 3m	Selection of underspeed protection threshold 50x(100%-αHz%) or 60x(100%-αHz%) αHz% is the position relative to the Hz trimmer or the percentage value of parameter 21
13	Common			
14	A.P.O.	Active protections output	Type: Non-insulated open collector Current: 100 mA Voltage: 30V Max length: 30m (**)	Active level (****), activating alarm and delay time programmable
15	Common			

tab_ECO_008-r00

* They are connected together on the board the following terminals: 2 and 3; 4 and 5; 6 and 7; 8 and 9; 11 and 13 and 15.

** With an external EMI SDR 128/K filter (3m without EMI filter).

*** Starting from version 10 of the Firmware. It is important not to exceed by more than ± 10%.

**** Starting from rev. 18 of the Firmware.



The regulators mounted on board the alternators prove to be calibrated during the final test. For loose regulators (for instance spare parts) or if wiring or calibration variations are required, you will have to perform an adequate setting of the regulator to guarantee its correct operation.

The basic settings may be performed directly on the regulator through the 4 trimmers (VOLT - STAB - Hz - AMP), the 50/60 jumper and the Vext input.

More detailed settings and measures may be performed only via software using, for instance, the Mecc Alte USB2DxR communication interface and the DxR_Terminal software.

Vext Input

The Vext input (connector CN1 terminals 10 and 11) allows the analog remote control of the output voltage through a 10Kohm potentiometer with a variation range that may be programmed via parameter 16 (by default the setting is ± 14% starting from version 10 of the Firmware) in relation to the value set by the VOLT trimmer or by parameter 19.

If you want to use continuous voltage, it will have an effect if contained within the range from 0V to +2,5V.

The input tolerates voltages from -5V to + 5V, but for values exceeding the 0V / +2.5V limits (or in case of disconnection) there are two available options:

- Not to consider the value (default configuration) and go back to the regulation of the voltage value set through the trimmer (if enabled) or through parameter 19.
- Maintain the minimum (or the maximum) reachable voltage value.

The two options can be set through the RAM Voltage CTRL flag in the Configuration Menu corresponding to the B7 bit of the configuration word P[10].



The continuous voltage supply must be able to absorb at least 2 mA.

In the regulation it is advisable not to exceed by more than $\pm 10\%$ the nominal voltage value of the alternator.

50/60 Signal

A jumper placed on the 50/60 input (connector CN1 terminals 12 and 13) entails the switching of the low speed protection threshold from $50 \cdot (100\% - \alpha Hz\%)$ to $60 \cdot (100\% - \alpha Hz\%)$, where $\alpha Hz\%$ is the related position of the HZ trimmer.

APO Contact

Acronym for Active Protection Output: (connector CN1 terminals 14 and 15) uninsulated open collector 30V-100mA transistor, by default normally closed (starting from revision 18 of the firmware; for firmware revisions up to 17 the transistor is normally open and it closes in case of an active alarm). It opens (with a software programmable delay of 1 to 15 seconds) when, one or several alarms, that may be selected separately via software, are active.

VOLT Trimmer

It allows regulation from approximately 70V to approximately 140V when terminals 4 and 5 are used for the sensing or from approximately 140V to approximately 280V when terminals 6 and 7 are used.

STAB Trimmer

It regulates the dynamic response (droop) of the alternator under transient conditions.

AMP Trimmer

It regulates the excitation overcurrent protection intervention threshold.

To calibrate the overload protection, perform the following procedure:

1. Rotate the Hz trimmer anticlockwise.
2. Apply nominal load to the alternator.
3. Reduce the speed by 10%.
4. Rotate the AMP trimmer completely in anticlockwise direction.
5. After a few seconds you should notice a reduction of the alternator voltage value and the activation of alarm 5 (indicated by a change in the LED flashing).
6. In this case slowly rotate the "AMP" trimmer in clockwise direction until you get the output voltage value to 97% of its nominal value: alarm 5 is still active.
7. If you go back to nominal speed, alarm 5 disappears after a few seconds and the alternator voltage rises back to the nominal value.
8. Readjust the Hz trimmer as indicated.

Hz Trimmer

It allows the regulation of the low speed protection intervention threshold up to -20% compared to the nominal speed value set by the 50/60 jumper (at 50 Hz the threshold may be adjusted from 40Hz to 50Hz, to 60 Hz the threshold may be adjusted from 48Hz to 60Hz).

The intervention of the protection diminishes the alternator voltage. Perform the adjustment as follows:

1. Rotate the Hz trimmer anticlockwise.
2. If the machine must operate at 60 Hz, make sure the jumper between terminals 12 and 13 of the CN1 connector is inserted.
3. Take the alternator to a speed equal to 96% of its nominal speed.
4. Slowly turn the "Hz" trimmer. Rotate it in clockwise direction until the alternator voltage starts to diminish and at the same time make sure the LED starts blinking fast.
5. By increasing the speed, the voltage of the generator should go back to normal and alarm should disappear.
6. Take the speed back to the nominal value.



Even if still continuing to regulate the voltage, the DSR goes into switch-off mode when the frequency decreases under 20 Hz. To restore it you need to shut down the alternator completely.

Alarm management



See paragraph 10.1.

Electrical diagrams



See paragraph 12.1.

8.2 DER1 Digital Regulator



The operation must be carried out by an electrical maintenance technician.



For further details on the regulators please refer to the specific manual.

Danger



Check with the alternator on.

Carefully perform the test, use adequate PPE such as for instance insulating gloves.



Voltage testing is performed off-load with the alternator running at nominal frequency. To obtain the voltage regulation use the VOLT potentiometer of the electronic regulator.

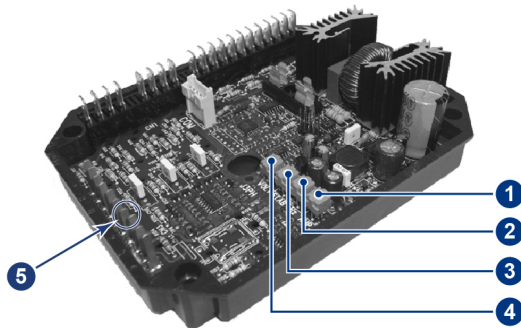

1. Regulation of the overload protection (AMP).
2. Adjustment of low frequency protection (Hz).
3. Adjustment of stability (STAB).
4. Adjustment of voltage (VOLT).
5. Terminals 29 and 30 for remote regulation of voltage.

dis_ECO_020-00

The self-regulation achieved through the DER1 digital regulator guarantees, under static conditions, a $\pm 1\%$ voltage accuracy with any power factor and with a speed variation ranging from -5% to $+20\%$.

Remote Regulation

To obtain a regulation within $\pm 14\%$ of the nominal value insert a $100\text{K}\Omega$ potentiometer in the dedicated terminals 29-30.

To obtain a regulation within $\pm 7\%$ of the nominal value insert a $25\text{K}\Omega$ linear potentiometer in series with a $3.9\text{K}\Omega$ resistor to halve the effect of the external potentiometer.

DER2 Digital Regulator

The DER2 regulator is assembled as a normal DER1 except for the USB2DxR communication interface that is substituted by the new $1\text{X}5$ p.2.54 mm strip connector that is mounted directly on the card. The alternators being equal, the DER2 regulator settings are the same as DER1.

8.2.1 Stability Adjustment

The alternators are part of a system that can be outlined as a motor + alternator. The alternator may therefore exhibit instabilities of the rotation regime and of the voltage due to the irregular operation of the motor it is connected to.

There is a potentiometer dedicated to the adjustment of this stability (STAB potentiometer), because the alternator voltage and motor speed regulation systems may go into conflict, causing both speed and voltage oscillations.

It is important to stress that Mecc Alte's alternators are testes using an electrical, and not a heat engine. Therefore, STAB adjustment is set correctly for the alternator driven by an electric motor.

General instructions to follow in case of instability problems:

1. Check the STAB potentiometer setting and make sure it corresponds to the settings reported in the tables below.
2. If there is no correspondence, reset the potentiometer to the value indicated in the table below; in case of missing information position in the middle.
3. If the problem persists, rotate the potentiometer anticlockwise a notch and repeat the test.
4. If no differences are noticed or the differences are minimal, rotate another notch anticlockwise; continue this procedure until the problem is solved.
5. If by rotating the potentiometer anticlockwise, the voltage instability increases, set the potentiometer as indicated at point 2. Rotate the potentiometer clockwise a notch and repeat the test
6. If there are no changes or they are minimal, rotate another notch clockwise and repeat the test.
7. Continue this procedure until the problem is solved.
8. If after these steps the problem is still not solved, you may need to adjust the stability (gain) of the motor speed regulation system. If this does not solve the problem either, try to change the stability software parameters of the voltage regulator. See the dedicated manual.

DER1 STAB TRIMMER							
Alternator		Nominal frequency = 50 Hz			Nominal frequency = 60 Hz		
Model	Pole	S [kVA]	STAB Position [tag]		S [kVA]	STAB Position [tag]	
			Single Phase	Three Phase		Single Phase	Three Phase
ECP4-1M/4 C (*)	4	6,5	-	-	7,8	-	-
ECP4-2M/4 C (*)	4	8	-	-	9,6	-	-
ECP4-3M/4 C (*)	4	10	-	-	12	-	-
ECP4-4M/4 C (*)	4	12,5	-	-	15	-	-
ECP4-5M/4 C (*)	4	15	-	-	18	-	-
ECP4-1L/4 C (*)	4	18	-	-	22	-	-
ECP4-2L/4 C (*)	4	20	-	-	24	-	-
ECP28-1VS/4 C (*)	4	7,5	-	-	9	-	-
ECP28-2VS/4 C (*)	4	10	-	-	12	-	-
ECP28-1S/4 C (*)	4	12,5	-	-	15	-	-
ECP28-2S/4 C (*)	4	15	-	-	18	-	-
ECP28-3S/4 C (*)	4	17.5	5 ½	5 ½	21	-	-
ECP28-M/4 C (*)	4	20	-	-	24	-	-
ECP28-L/4 C (*)	4	25	-	-	30	-	-
ECP28-VL/4 C (*)	4	30	-	-	36	-	-
ECP30-1M/4 C (*)	4	20	-	-	24	-	-
ECP30-2M/4 C (*)	4	25	-	-	30	-	-
ECP30-3M/4 C (*)	4	30	-	-	36	-	-
ECP30-1L/4 C (*)	4	35	-	-	42	-	-
ECP30-2L/4 C (*)	4	40	-	-	48	-	-
ECP32-1S/4 C (*)	4	37.5	-	-	45	-	-
ECP32-2S/4 C (*)	4	45	-	-	54	-	-
ECP32-1M/4 C (*)	4	50	-	-	60	-	-
ECP32-2M/4 C (*)	4	62.5	-	7 ½	75	-	7 ½
ECP32-1L/4 C (*)	4	75	8	-	90	-	-
ECP32-2L/4 C (*)	4	82.5	-	-	100	-	-
ECP34-1S/4 C (*)	4	87.5	-	-	105	-	-
ECP34-2S/4 C (*)	4	100	-	8 ½	120	-	8 ½
ECP34-1M/4 C (*)	4	125	-	7 ½	150	-	7 ½
ECP34-2M/4 C (*)	4	135	-	-	162	-	7 ½
ECP34-1L/4 C (*)	4	150	-	-	180	-	-
ECP34-2L/4 C (*)	4	165	-	-	198	-	-

* DER 1: P[11] = 4, P[12] = 3, P[13] = 16384, quadratic function with integral gain.

** DER 1/A: P[11] = 5, P[12] = 1, P[13] = 26624, linear function with integral gain

*** DER 1/A: P[11] = 7, P[12] = 1, P[13] = 26624, linear function with integral gain

8.2.2 Protections

To avoid anomalous and dangerous operation of the alternator, the DER1 digital regulator is equipped with a low speed protection and an overload protection.

Low speed protection

Its intervention is instantaneous and it causes the reduction of the alternator voltage when the frequency drops by $4 \pm 1\%$ under the nominal frequency.

The intervention threshold is set using the "Hz" potentiometer.

Overload protection

A dedicated circuit compares the partialized excitation voltage. If the preset value for this voltage (a value corresponding with a load current value equal to 1.1 times the current indicated on the alternator tag) is exceeded for more than 20 seconds, the regulator steps in lowering the alternator voltage and subsequently limiting the current within a safe value range.

The delay is expressly introduced to allow the motors that normally start in 5÷10 seconds to pick-up. This intervention threshold may be adjusted using the "AMP" potentiometer.

Causes that lead to protection intervention.

Instantaneous protection intervention for low speed	1 - Speed reduced by $4 \pm 1\%$ as compared to the rated data.
Delayed protection intervention for overload	2 - Overload of 10% as compared to the rated data.
	3 - Power factor ($\cos \phi$) lower than the rated data.
	4 - Environmental temperature above 50°C.
Intervention of both protections	5 - Combination of factor 1 and factors 2, 3, 4.

In case both protections intervene, the voltage supplied by the alternator will drop to a value that depends on the size of the fault.

Voltage will be automatically restored to its nominal value when the fault is solved.

8.2.3 Inputs and Outputs: technical specifications

TABLE 1 CONNECTOR CN 1				
Term. (*)	Name	Function	Specification	Notes
1	Exc-	Excitation	Continuous Rating: 5 Adc Transitory Rating: 12 Adc at peak	
2	Aux / Exc+			
3	Aux / Exc+	Power	40 ÷ 270 Vac Frequency 12 ÷ 72Hz (**)	(*)
4	UFG	Sensing Range 2	Range 2: 150 ÷ 300 Vac Burden: < 1VA	U channel
5	UFG			
6	UHG	Sensing Range 1	Range 1: 75 ÷ 150 Vac Burden: < 1VA	
7	UHG			
8	UHB	Jumper Range 1		Short for sensing 75 ÷ 150 Vac
9	UFB			
10	UFB			Star point of YY or Y connection, in common with board feeding (*)
11	UFB	Board reference		
12	UFB			
13	/		Not present	
14	VFG	Sensing	Range 1: 75 ÷ 150 Vac Burden: < 1VA	V channel, to be connected in parallel to U channel in case of single phase sensing
15	VHG	Sensing Range 1		
16	VHB		Range 2: 150 ÷ 300 Vac Burden: < 1VA	
17	VFB	Range 2		
18	/		Not present	
19	WFG	Sensing	Range 1: 75 ÷ 150 Vac Burden: < 1VA	W channel, unused (with shorted inputs) in case of single phase sensing
20	WHG	Sensing Range 1		
21	WHB		Range 2: 150 ÷ 300 Vac Burden: < 1VA	
22	WFB	Range 2		

tab_ECO_010-r00

* They are connected together on the board the following terminals: 2 and 3; 4 and 5; 6 and 7; 9 and 10, 11 and 12.

** Minimum supply voltage 40Vac at 15Hz, 100V at 50Hz, 115V at 60Hz.

TABLE 2 CONNECTOR CN 3				
Term. (*)	Name	Function	Specifications	Notes
23	Common	Active protections output	Type: Non-insulated open collector Current: 100 mA Voltage: 30 V Max length: 30m (***)	Active level(*****), activating alarm and delay time programmable
24	A.P.O.			
25	Common	Jumper 50/60 Hz	Type: Not insulated Max length: 3m	Selection of underspeed protection threshold
26	50/60 Hz			
27	0EXT	Jumper for remote voltage control 0÷2,5 Vdc	Type: Not insulated Max length: 3m	Short for 0÷2,5Vdc input or potentiometer
28	JP1			
29	0EXT	Input for remote voltage	Type: Not insulated Max length: 30m (***)	Regulation: ± 10% (*****)
30	PEXT	Input for remote voltage control 0÷2,5 Vdc or Pext	Input: 0÷2,5 Vdc or 100K Potentiometer	Burden: 0÷1mA (sink)
31	JP2	Pext jumper	Type: Not insulated Max length: 3m	Short for 0÷2,5Vdc input or potentiometer
32	± 10 V	control ± 10 Vdc	Input: ± 10 Vdc	Burden: ± 1mA (source/sink)

tab_ECO_011-r00

*** With an external EMI filter (3m without the EMI filter).

**** 50-(100%-αHz%) or 60-(100%-αHz%) where αHz% is the position in relation to the Hz trimmer or the percentage value of the P[21] parameter.

***** Values not to be exceeded, the actual range depends on the P[16] parameter.

***** Starting from rev. 18 of the firmware.



The regulators mounted on board the alternators prove to be calibrated during the final test. For loose regulators (for instance spare parts) or if wiring or calibration variations are required, you will have to perform an adequate setting of the regulator to guarantee its correct operation.

The basic settings may be performed directly on the regulator through the 4 trimmers (VOLT - STAB - Hz - AMP), the 50/60 jumper, JP1, JP2 and the Pext input.

More detailed settings and measures may be performed only via software using, for instance, the Mecc Alte USB2DxR communication interface and the DxR_Terminal software.

Remote control of voltage

The Pext inputs (terminal 30) and $\pm 10V$ (terminal 32) allow the analog remote control of the output voltage through a continuous voltage or a potentiometer, with a programmable variation range with respect to the value set through the trimmer (by default) or through the P[19] parameter.



Figura 1: senza saturazione della tensione di uscita al raggiungimento dei limiti della tensione di ingresso.



Figura 2: con saturazione della tensione di uscita al raggiungimento dei limiti della tensione di ingresso.

If you want to use a continuous voltage it will have an effect if contained within the $0V_{dc}/2,5V_{dc}$ or $-10V_{dc}/+10V_{dc}$ range, if connected respectively between the terminals 30 and 29, or 32 and 29 and based on the presence or absence of the JP1 and JP2 jumpers.

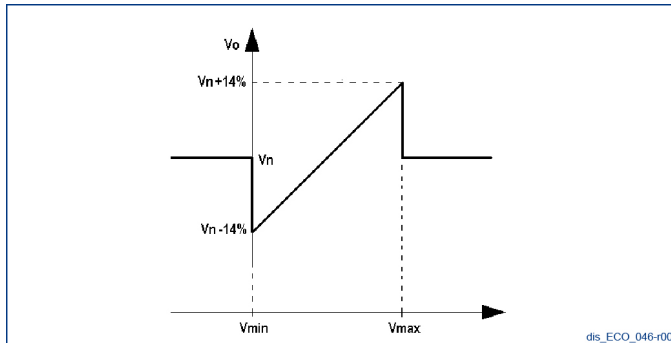
For values that exceed the above-mentioned limits (or in case of disconnection) you have two available options:

- Not to consider the value and go back to the regulation of the voltage value set through the trimmer (if enabled) or through parameter P[19], fig. 1.
- Maintain the minimum (or the maximum) reachable voltage value, fig. 2.

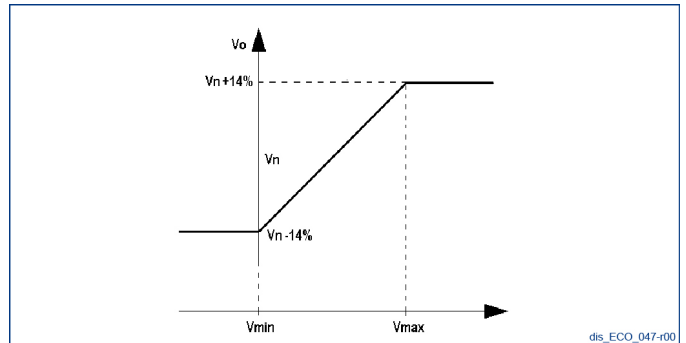
The second option can be set through the RAM Voltage CTRL flag in the Configuration Menu corresponding to the B7 bit of the configuration word P[10].



See the technical guide: DER 1 Digital Regulator.



The continuous voltage supply must be able to absorb at least 2 mA.

In the regulation it is advisable not to exceed by more than $\pm 10\%$ the nominal voltage value of the alternator.

50/60 Signal

A jumper placed on the 50/60 input (terminals 25 and 26) entails the switching of the low speed protection threshold from $50 \cdot (100\% - \alpha Hz\%)$ to $60 \cdot (100\% - \alpha Hz\%)$, where $\alpha Hz\%$ is the related position of the HZ trimmer.

APO Contact

Acronym for Active Protection Output: (connector CN3 terminals 23 and 24) uninsulated open collector 30V-100mA transistor, by default normally closed (starting from revision 19 of the firmware; for firmware revisions up to 18 the transistor is normally open and it closes in case of an active alarm). It opens (with a software programmable delay of 1 to 15 seconds) when, one or several alarms, that may be selected separately via software, are active.

VOLT Trimmer

It allows regulation from approximately 75V to approximately 150V when terminals 6/7 - 10/11/12 (with an 8-9 jumper) 15-16 and 20-21 are used for the sensing or from approximately 150V to approximately 300V when terminals 4/5 - 9/10/11/12, 14-17 and 19-22 are used.

STAB Trimmer

It regulates the dynamic response (droop) of the alternator under transient conditions.

It must not be rotated to minus two notches counted in clockwise direction.

AMP Trimmer

It regulates the excitation overcurrent protection intervention threshold.

To calibrate the overload protection, perform the following procedure:

1. Rotate the AMP trimmer completely in clockwise direction.
2. Feed the alternator an overload having $\cos \phi = 0.8$ or $\cos \phi = 0$ respectively equal to 125% or 110% of the nominal load.
3. After two minutes slowly turn the AMP trimmer anti-clockwise until you get a reduction of the generator's voltage value and the activation of alarm 5 (visible through a change in the LED flashing)
4. Adjust the AMP trimmer so as to get an output voltage value of 97% of the nominal value: alarm 5 is still active
5. If the load is removed, alarm 5 disappears after a few seconds and the generator voltage goes back to the nominal value.

Hz Trimmer

It allows the regulation of the low speed protection intervention threshold up to -20% compared to the nominal speed value set by the 50/60 jumper (at 50 Hz the threshold may be adjusted from 40Hz to 50Hz, to 60 Hz the threshold may be adjusted from 48Hz to 60Hz).

The intervention of the protection diminishes the alternator voltage. Perform the adjustment as follows:

1. Rotate the Hz trimmer anticlockwise.
2. If the machine must operate at 60 Hz, make sure the jumper between terminals 25 and 26 is inserted.
3. Take the alternator to a speed equal to 96% of its nominal speed.
4. Slowly regulate the "Hz" trimmer. Rotate it in clockwise direction until the alternator voltage starts to diminish and at the same time make sure the LED starts blinking fast.
5. By increasing the speed, the voltage of the generator should go back to normal and alarm should disappear.
6. Take the speed back to the nominal value.



Even if still continuing to regulate the voltage, the DER1 goes into switch-off mode when the frequency decreases under 20 Hz. To restore it you need to shut down the alternator completely.

Alarm management



See paragraph 10.2.

Electrical diagrams



See paragraph 12.2.

8.3 UVR6-SR7 analog regulators



The operation must be carried out by an electrical maintenance technician.



For further details on the regulators please refer to the specific manual.

Danger



Check with the alternator on.

Carefully perform the test, use adequate PPE such as for instance insulating gloves.



Voltage testing is performed off-load with the alternator running at nominal frequency. To obtain the regulation of voltage within $\pm 5\%$ of the nominal value turn the voltage potentiometer of the electronic regulator.

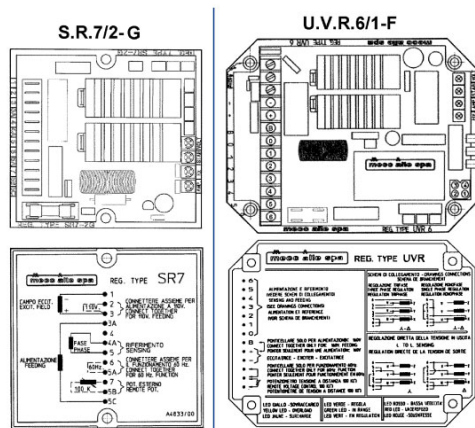

dis_ECO_025-r00

The following regulators are obsolete and were replaced by DSR/DER1 electronic regulators.

The U.V.R.6/1-F e S.R.7/2-G regulators may be equally used with the ECP series without altering performance.

The U.V.R.6/1-F was standard fit in the 38 - 40 - 43 - 46 types, while the S.R.7/2-G was standard fit in the 28 - 31 - 32 - 34 series.

The two regulators are perfectly equal as far as performance is concerned but they are different in terms of signaling and reference.

Remote Regulation

To obtain the remote regulation of voltage within a $\div 5\%$ range of the nominal value, insert:

- A 100K Ω potentiometer for the alternators equipped with 6 terminals
- A 100K Ω potentiometer in series with a 100K Ω resistor for the alternators with 12 terminals.

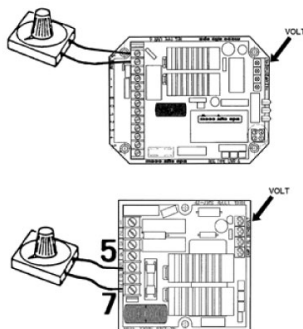

dis_ECO_026-r00

For a correct operation of the alternator connect the remote potentiometer as follows:

- Rotate the VOLT trimmer of the electronic regulator completely in anticlockwise direction.
- Position the external potentiometer at half scale and connect it with the corresponding terminals of the electronic regulator.
- Adjust the voltage to the nominal value through the VOLT trimmer of the electronic regulator.

Protections

To avoid anomalous and dangerous operation of the alternator, the U.V.R.6/1-F - S.R.7/2-G. analogic regulators are equipped with a low speed protection and an overload protection.

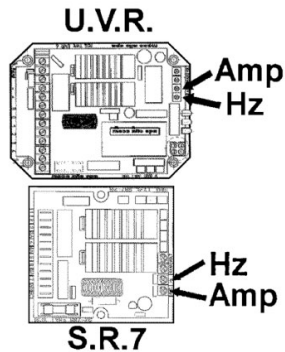

Low speed protection

Its intervention is instantaneous and it causes the reduction of the alternator voltage when the frequency under 10% of the nominal frequency.

The intervention threshold is set using the "Hz" potentiometer.

Overload protection

A dedicated circuit compares the partialized excitation voltage. If the preset value for this voltage (a value corresponding with a load current value equal to 1.1 times the current indicated on the alternator tag) is exceeded for more than 20 seconds, the regulator steps in lowering the alternator voltage and subsequently limiting the current within a safe value range.

The delay is expressly introduced to allow the motors that normally start in $5 \div 10$ seconds to pick-up. This intervention threshold may be adjusted using the "AMP" potentiometer.



If the alternator is used in single phase or with voltages different than the ones set by the manufacturer, a readjustment of the AMP and STAB potentiometers might be necessary.

U.V.R.6/1-F Signals

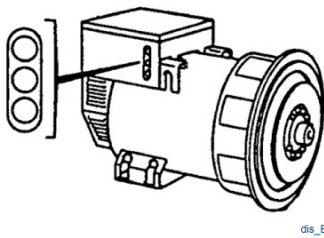

The U.V.R.6/1-F regulator has the following characteristics:

1. Possibility to also have a three phase reference besides the single phase one.
2. LED signals of auto diagnosis that indicate the operation conditions of the machine:
 - A green LED: if normally lit it indicates normal operation of the alternator.
 - A red LED: when lit it indicates the intervention of the low speed protection.
 - A yellow LED: when lit it indicates the intervention of the overload protection.



During normal operation of the alternator, only the green LED must be lit.

All these signals may be managed remotely and used for various purposes through the use of the SPD96/A device, available on request.

Causes that lead to protection intervention.

Instantaneous protection intervention for low speed	1 - Speed reduced by 10% as compared to the rated data.
Delayed protection intervention for overload	2 - Overload of 20% as compared to the rated data.
	3 - Power factor ($\cos \phi$) lower than the rated data.
	4 - Environmental temperature above 50°C.
Intervention of both protections	5 - Combination of factor 1 and factors 2, 3, 4.

In case both protections intervene, the voltage supplied by the alternator will drop to a value that depends on the size of the fault.

Voltage will be automatically restored to its nominal value when the fault is solved.

Optionals

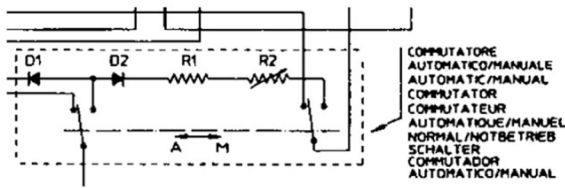

dis_ECO_029-r00

All the alternators in the ECP series may also be operated with manual regulation, without the assistance of external supplies and with the simple use of one rheostat.

9 Maintenance

9.1 General Instructions



Warning

Before executing any maintenance operation, read carefully the instructions in chapter 3 "Safety" of this manual.



Warning

The authorized operators are only allowed to carry out the works they are specifically qualified for on the alternator and wear the required PPE (personal protective equipment).



Warning

Always disconnect the alternator from power supplies before carrying out any maintenance and/or replacement operation.



Warning

The alternators, when working, release heat even to a high level based on the power being generated. Before touching it wait for the alternator to cool off.



Danger

It is forbidden to pass through or stand under the alternator during the lifting and transportation stages.



It is advisable for the maintenance technician to keep a register of all the interventions.

The ECP series alternators are built to operate without maintenance for a long time.

The maintenance interventions on the Mecc Alte alternator are divided into ordinary and extraordinary.

9.2 Maintenance summary table

9.2.1 Summary table of ordinary maintenance operations

Acronyms of the intervention types: E = Electrical; M = Mechanical; S = Software

Type	Description	Periodicity	Reference
M	Alternator exterior and interior cleaning	Every 15 days	9.3.7
M	General cleaning	Every 400 hours	9.3.1
M	Air filter cleaning (if present)	Every 400 hours of use	9.3.2
M	Visual Inspection	Every 2500 hours	9.3.3
M	Verification of winding state	Every 2500 hours	9.3.4
M	Verification of correct alternator operation	Every 2500 hours	9.3.5
M	Tightening torque check	Every 2500 hours	9.3.6

9.2.2 Summary table of extraordinary maintenance operations

Acronyms of the intervention types: E = Electrical; M = Mechanical; S = Software

Type	Description	Periodicity	Reference
M	Maintenance and potential replacement of bearings	Every 4000 hours	9.4.1
E	Winding state and diode bridge fastening check	Every 8000 hours / 1 year	9.4.2
S	Copy of the alarms of the digital regulator	Every 8000 hours / 1 year	9.4.3
M	Cleaning of windings	Every 20000 to 25000 hours	9.4.5

9.2.3 Summary table of maintenance operations in case of failure

Acronyms of the intervention types: E = Electrical; M = Mechanical; S = Software

Type	Description	Periodicity	Reference
M	Fan replacement assembling	-	9.5.1
E	Verification and potential replacement of diode bridge	-	9.5.2
M	Mechanical disassembling for inspection	-	9.5.3
M	Mechanical assembling	-	9.5.4
M	Disc Holder Hub Removal (34 series)	-	9.5.8
E	Loss of residual magnetism (re-excitation of the machine)	-	9.5.9
E	Verification and replacement of voltage regulator	-	9.5.10
E	DSR test and setup on test bench	-	9.5.11
E	DER1 test and setup on test bench	-	9.5.12
E	DER 2 test and setup on test bench	-	9.5.13
E	Main stator windings voltage test	-	9.5.14

9.3 Ordinary Maintenance

Ordinary maintenance means the set of operations that are carried out on a regular basis.

Their purpose is to maintain the alternator in good operational state.



Caution

Carry out ordinary maintenance with accuracy and as often as specified by the manufacturer.

9.3.1 General cleaning



The intervention described in this paragraph refers only to the alternator, the frequency proposed must be adapted to the actual conditions and the frequency of use.



Danger

Disconnect the alternator from the power supplies. The drive motor must be off and unplugged from its power supplies.



Warning

Never use liquids or water.



Warning

Never clean the internal electrical components of the terminal box with pressurized air because short circuits or other malfunctions may occur.



Warning







Move close to the alternator only when it has zero power supply and it is at room temperature. It is only now that you may clean it on the outside with pressurized air.

Carry out general cleaning of the alternator and the surrounding area.

During the cleaning check the state and make sure that the various parts of the alternator are undamaged.

In case of anomalies or damages contact the maintenance technician for a potential intervention/replacement.

9.3.2 Air filter cleaning (if present)

Type of intervention 	Operator 	Periodicity  Every 400 hours of use
PPE to wear   		Materials and equipments Cleaning tools

Danger
 Disconnect the alternator from the power supplies. The drive motor must be off and unplugged from its power supplies.

 The intervention periodicity indicated refers to critical environmental conditions. Adapt the periodicity based on the actual conditions of use.

The air filters are accessories that are assembled on customer request.

Air filters must be regularly cleaned because they hold within a net that must be kept clean to guarantee the efficiency of the filter and the consequent good operation of the alternator.



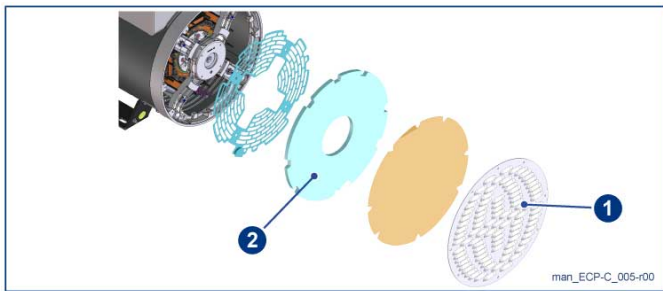





The periodicity of intervention on the air filters will depend on the severity of the conditions at the installation place. However a regular inspection of these components will allow you to determine if you should intervene.



Remove the grid (1).
Remove the filter elements (2) and clean.









Reassemble everything according to the initial configuration.

9.3.3 Visual Inspection

Type of intervention 	Operator 	Periodicity  Every 2500 hours.
PPE to wear     		Materials and equipments Workshop tools.

- Check for the presence of anomalies such as cracks, rust, leakages and any other anomalous event.
- Check the tightening of the power cables and of the regulator cables.
- Check the state of the insulations of the power cables and of the regulator cables (overtemperature, rubbing).

9.3.4 Verification of winding state

Type of intervention 	Operator 	Periodicity  Every 2500 hours
PPE to wear     		Materials and equipments "Megger" Tester or similar to 500V in continuous voltage.

Danger
 Disconnect the alternator from the power supplies. The drive motor must be off and unplugged from its power supplies.

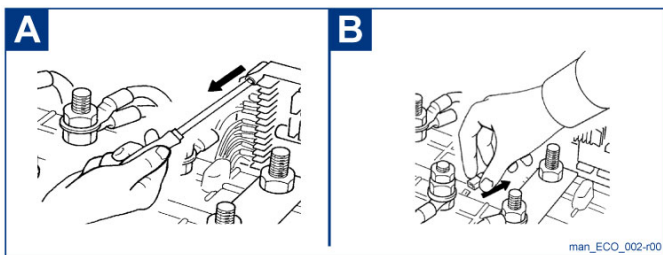



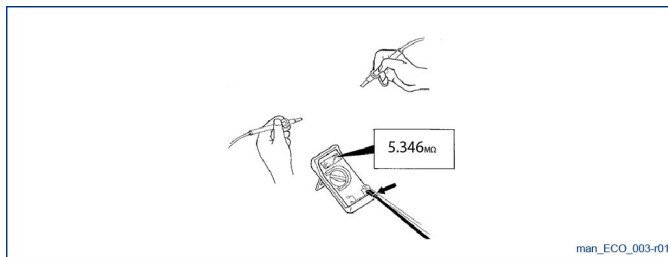





i Before carrying out the verification disconnect the voltage regulator (fig. A), the radio interference filters (fig. B) and all the other potential devices electrically connected to the windings to check.



Measure insulation resistance to ground.
The measured value of resistance to ground of all the windings must be higher than 5MΩ.

i If the value is lower than 5MΩ dry the windings with a jet of hot air at 50-60°C. Direct the jet of air into the air intakes and exhausts of the alternator.

9.3.5 Verification of correct alternator operation









Type of intervention 	Operator 	Periodicity  Every 2500 hours
PPE to wear     		Materials and equipments Workshop tools.

Check whether the alternator operates regularly without noises or anomalous vibrations.

In presence of noises and/or vibrations, check:

- The balancing of the rotor.
- The state of the alternator bearings. If necessary replace them (see 9.4.1.).
- The alignments.
- The potential presence of stresses in the heat engine.
- The potential presence of stresses in the anti-vibration supports.
- The functional data (see the nameplate of the alternator paragraph 1.6).

9.3.6 Tightening torque check

Type of intervention 	Operator 	Periodicity  Every 2500 hours
PPE to wear     		Materials and equipments The torque wrench.







Danger



Disconnect the alternator from the power supplies. The drive motor must be off and unplugged from its power supplies.

- Check the bolt tightening (see paragraph 9.6 "Tightening torques").
- Check the electrical connections.

9.3.7 Alternator exterior and interior cleaning

Type of intervention 	Operator 	Periodicity  Every 15 days
PPE to wear   		Materials and equipments Pressurized air.

Clean with pressurized air.

 It is strictly forbidden to use any kind of high-pressure water jet cleaners and detergent liquids. The standard protection rating of the alternator is IP23 and therefore by using liquids anomalies or even short circuits may occur.

 The intervention periodicity indicated refers to critical environmental conditions. Adapt the periodicity based on the actual conditions of use.

9.4 Extraordinary maintenance



Caution









Carry out extraordinary maintenance with accuracy and as often as specified by the manufacturer.



Warning

All the maintenance intervals described below refer to a normal use of the alternator. In case it is used in more severe conditions (high humidity, temperature or dust) it is necessary to check it more often.

9.4.1 Maintenance and potential replacement of bearings

Type of intervention 	Operator 	Periodicity  Every 4000 hours
PPE to wear     		Materials and equipments SKF LGMT2 or ENS or equivalent greases.



Danger

Disconnect the alternator from the power supplies. The drive motor must be off and unplugged from its power supplies.

- Check the state of the bearings.
- Lubricate the bearings if they are equipped with a lubricator.





Bearing lubrication table

Alternator type	Bearing type	
	Coupling side	Side opposite the coupling
ECP 4	-	6305.2RS
ECP 28	6309.2RS	6207.2RS
ECP 30	-	6207.2RS
ECP 32	6312.2RS	6309.2RS
ECP 34	6314.2RS	6311.2RS

On ECP 4-28-30-32-34 sealed bearings are fitted: it is not necessary any maintenance during their entire operating life; in normal working conditions the estimated life is about 30,000 hours.

For any replacement of the bearings follow the instructions in paragraph 9.5.3

9.4.2 Winding state and diode bridge fastening check

Type of intervention 	Operator 	Periodicity  Every 8000 hours / 1 year
PPE to wear 		Materials and equipments Workshop tools.





Danger



Disconnect the alternator from the power supplies. The drive motor must be off and unplugged from its power supplies.

Remove the back grid of the alternator for visual inspection of the windings and to check the fastening of the diode bridge. If the windings are dirty or oily clean them with pressurized air. In case problems of other kind are detected you must disassemble the alternator to solve them.

9.4.3 Copy of the alarms of the digital regulator

Type of intervention 	Operator 	Periodicity  Every 8000 hours / 1 year
PPE to wear 		Materials and equipments Personal Computer + interface + dedicated software.







Danger



Disconnect the alternator from the power supplies. The drive motor must be off and unplugged from its power supplies.

Mecc Alte's digital regulator are equipped with a special connector that allows you to download the data related to the recorded alarms. Download this data to check the potential presence of anomalies and, if any, solve them.

9.4.4 Cleaning of windings

Type of intervention 	Operator 	Periodicity  Every 20000 to 25000 hours.
PPE to wear   		Materials and equipments Cleaning tools

Danger



Disconnect the alternator from the power supplies. The drive motor must be off and unplugged from its power supplies.

Caution



If the system operates in a dusty environment, the cleaning operations must be carried out more frequently.



Cleaning must be carried out using adequate products.

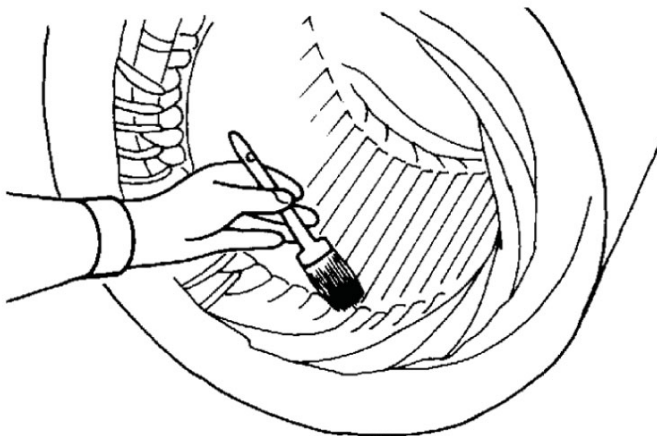









dis_ECO_001-r00

Disassemble the alternator for general cleaning. In such case it is advisable to replace the bearings for an optimization of the maintenance interventions for the entire group. The windings must be cleaned using a low pressure jet of hot water at a temperature below 80 °C or using adequate highly-evaporable solvents suitable for the cleaning of electrical windings. These solvents allow an adequate cleaning without damaging the insulation of the windings.

When the cleaning is finished it is advisable to check if there are any signs of overheating and potential traces of carbonizations. After the drying process at approximately 60-80°C is finished you must check again the insulation resistance of the windings. In case you notice a degradation of the winding paint, paint them again.

9.5 Maintenance in case of failure

9.5.1 Fan replacement assembly

Type of intervention 	Operator 	Periodicity 
PPE to wear     		Materials and equipments Workshop tools.

Danger



Disconnect the alternator from the power supplies. The drive motor must be off and unplugged from its power supplies.

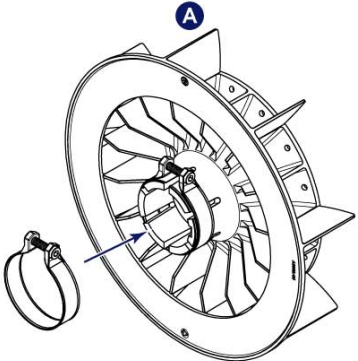

A Insert the clamp on the fan

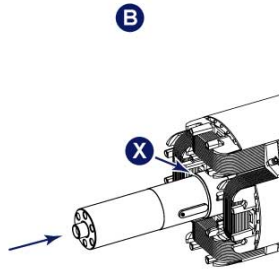

B Insert the fan in the shaft until reaching the (X) edge.
 Type 1 (shaft knurled) and Type 2 (shaft with keys)

ins_ECP-C_054-r00

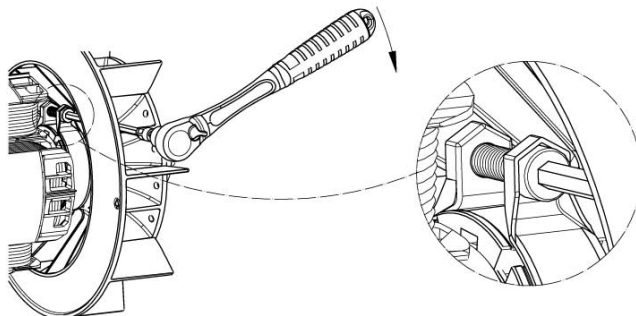

C Tight the M8 screw with tightening torque of $12,5 \text{ Nm} \pm 5\%$



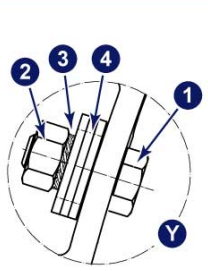

D To balance the main rotor assemble the fasteners as show in detail (Y). If necessary, repeat the assembly in other holes until to get the prescribed balancing value. If does not reach the prescribed balancing with the only screws, add balancing pasta on the winding rotor inside.



ins_ECP-C_053-r00

No.	Description	Qty	Code
1	Hex head ball M6x16 CL.4.8 DIN558	1	6110605215
2	Nut M6 CL.8 UNI-5587	1	6110601030
3	Washer ext. Toohead D.6 DIN6798	1	6110613220
4	Washers D.6	Max. 3	6110613068 6110613030

9.5.2 Verification and potential replacement of diode bridge

Type of intervention 	Operator 	Periodicity 
PPE to wear 		Materials and equipments Workshop tools.

Danger



Disconnect the alternator from the power supplies. The drive motor must be off and unplugged from its power supplies.

ECP 4-28-30

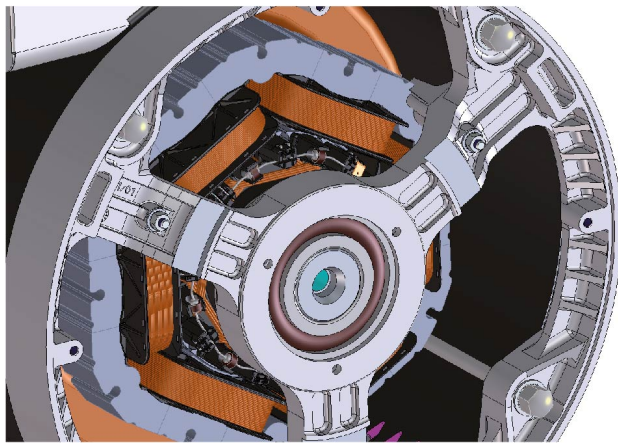

ECP 28-30-32-34

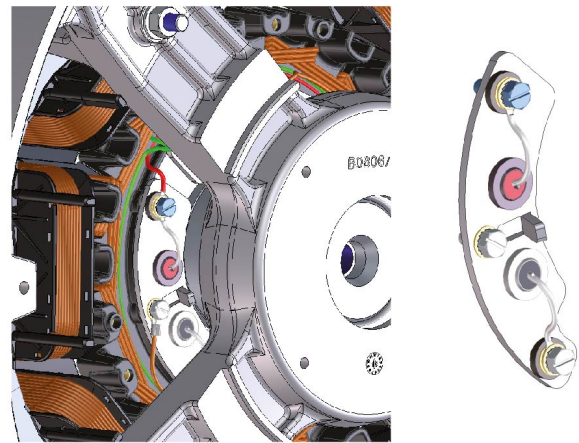

lay_ECP-C_001-r00

ECP series alternators are equipped with button-type diodes, mounted directly in the exciter holder (series 4-28-30), or mounted on a removable diode bridge (T30), divided into three sectors (series 28-30-32-34).

In case of T30 diode bridge, each single diode can be easily inspected with a diode check multimeter specially set for diode check; completely disconnect the three sectors and check each diode (2 per sector) in both directions. In the event of one or more failures, it is advisable to replace the complete bridge. Once the whole bridge, is replaced, remember to tighten the screws with a suitable tightening wrench (par. 9.6) and to strictly comply with the polarities (figure above for ECP 28-30-32-34, figure A and B for ECP 4-28-30).

In order to simplify the access to the diode bridge we recommend to remove the main rotor (if the alternator is not coupled with the engine) or the non drive end bracket. In this last case it is sufficient to unscrew the stay bolts and use a special extractor to remove the bracket.

In case of 4-28-30 alternator series, follow the steps in order to verify the diodes.

Necessary equipment :

- A. 12V battery
- B. 12V-21W lamp (or alternatively 6.8Ω - 30W resistance)
- C. Voltmeter (for instance, multimeter on scale VOLT d.c)



before performing the following actions, it is necessary to disconnect the 2 cables connecting the main rotor to the diode bridge (+ and -).

Test of the diodes on the “negative”

-) Connect the equipment, as it is pointed out in the picture A
-) Fix the cable connected to the lamp to the negative terminal of the bridge, as it is pointed out in the picture A
-) Connect the terminal “Probe” (Y) to the point A1, A2, and A3 in sequence to check the diodes 1,2 e 3 respectively; check the readings on the voltmeter in relation with what is reported on the table.

Test of the diodes on the “positive”

-) Connect the equipment, as it is pointed out in the picture B
-) Fix the cable connected to the negative terminal of the battery to the positive terminal of the bridge, as it is pointed out in the picture B
-) Connect the terminal “Probe” to the point A4, A5, and A6 in sequence to check the diodes 4,5 e 6 respectively; check the readings on the voltmeter in relation with what is reported on the table.

4 POLE	MEASURED VOLTAGE		
	ALTERNATOR TYPE	GOOD DIODE	SHORT CIRCUIT DIODE
ECP4/4	0.8V ÷ 1.2V	<0.6V	>1.3V
ECP28/4	0.8V ÷ 1.2V	<0.6V	>1.3V
ECP30/4	0.8V ÷ 1.2V	<0.6V	>1.3V

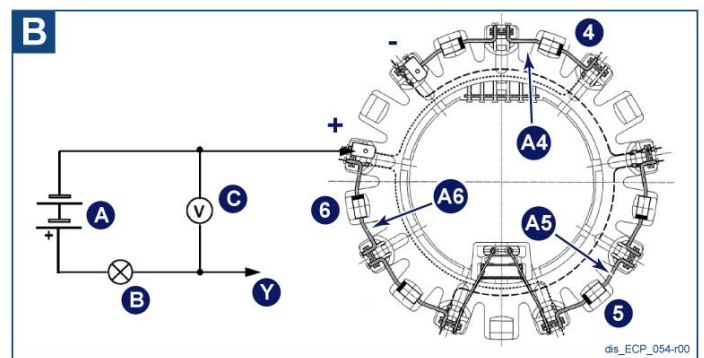
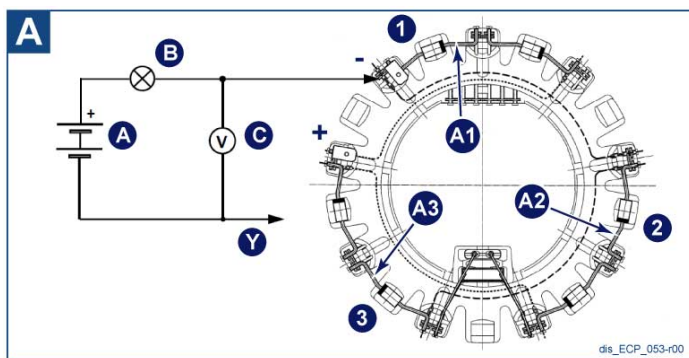



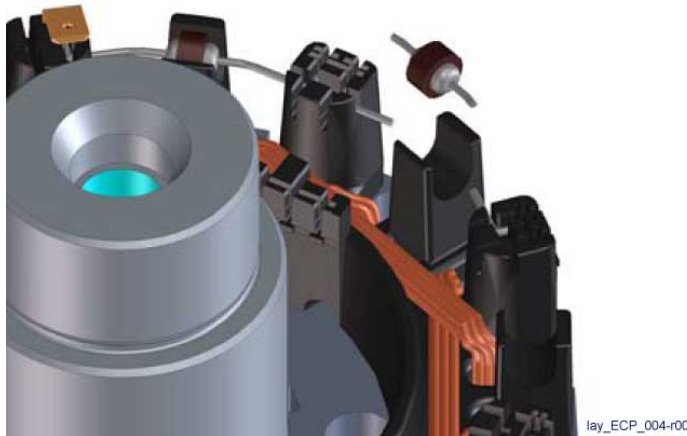





Instruction to replace the diode



When the values measured point out a diode damaged, it is necessary to replace the component. For this purpose it is recommended to not pull the rheophores out from their locations, but to cut them near to the body of the component; then fit in the new component respecting the polarity and soft solder accurately the rheophores with the pieces remained in their locations.

9.5.3 Mechanical disassembly for inspection





Type of intervention 	Operator 	Periodicity 
PPE to wear     		Materials and equipments Workshop tools.

Danger



Disconnect the alternator from the power supplies. The drive motor must be off and unplugged from its power supplies.

Summary Disassembly Procedure.

Front Cover	To remove the front cover gently tap with a rubber mallet.
Rotor	The rotor is extracted from the front side; in performing this operation care must be taken to ensure the rotor does not fall.  During this operation you must be very careful not to damage the rotor windings.
Rear bracket	To dismantle the rear bracket, it must be secured to a suitable lifting system and an extractor must be used.  With the extractor, the shaft must be pushed until the bearing comes out completely from its seat.
General Inspection	Examine every component (windings: exciter, auxiliary winding, stator and rotor) to check the presence of damages.  Carefully check whether the crimp connectors are damaged.
Stator/Frame Inspection	<ul style="list-style-type: none"> ● Carry out a visual inspection of the stator and of the frame. ● Remove all dirt and dust. ● Repair all potential damages to the windings. ● Inspect the cable terminals and make sure they comply with the applicable regulations.
Shaft Inspection	Examine the shaft and the housings for the keys to check the presence of any sign of corrosion, burrs or wear. Clean them and, if necessary polish them.  If the degree of wear of the shaft is too high, take it to a service center for repair or replacement.

**Front/Back bearing
disassembling**

- Both bearings must be removed using the appropriate extractors.
- The sizes of the bearings must be measured accurately to check the presence of excessive wear.
- In case of excessive wear or anomalous noises / vibrations, replace them.

Electrical Inspections

Check the cable terminals and make sure they guarantee good contact. Make sure there are no signs of corrosion and/or oxidation.

Check whether the cable sheath is undamaged. If there are damage signs, repair or replace the cable.

Using adequate tools, check the resistance, the continuity and the insulation of the following windings (see paragraph 9.5.10):

- Main Stator.
- Auxiliary Winding.
- Main rotor.
- Exciter Stator.
- Exciter Rotor.
- Thermal probes (if present).

Check whether the diodes and the varistor are damaged.



All the measurement tools must be calibrated.

Insulation checks

Check the insulation resistance of the following windings:

Main Stator:

- Between phases and between phases and ground.
- Between phases and the auxiliary winding.
- Between auxiliary winding and ground.

Main rotor and exciter rotor:

- Between winding and ground.

Exciter Stator:

- Between winding and ground.

The AVR may be controlled on a static bench or during the operating test of the machine



See paragraph 9.5.10.

The internal windings of the machine might need accurate cleaning. Use an appropriate solvent or hot water. Dry them and, if necessary, impregnate them again.

Detailed disassembling procedure

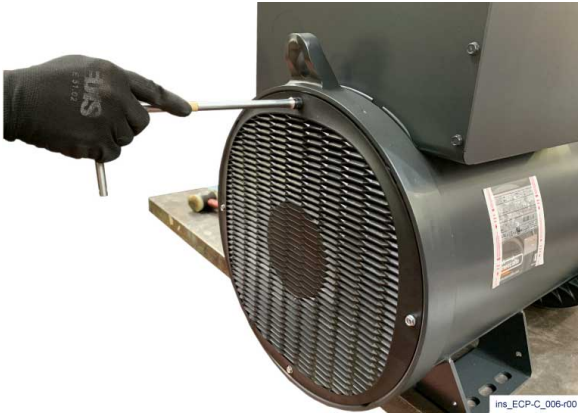

1) Remove terminal box lid and rear grid.



2) Cut cable tie of the regulator wires, remove the yellow and blue cable from regulator and pull it through its hole in the frame.



3) Remove the cover stay bolt.

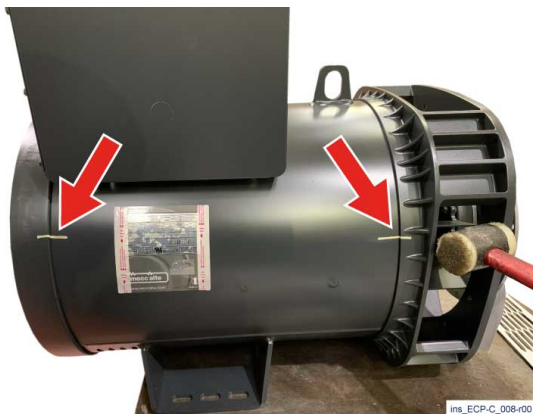

4) Remove the drive end bracket using a soft hammer. Note that the position of the drive end bracket and non drive end bracket respect of the frame was signed using a pen.

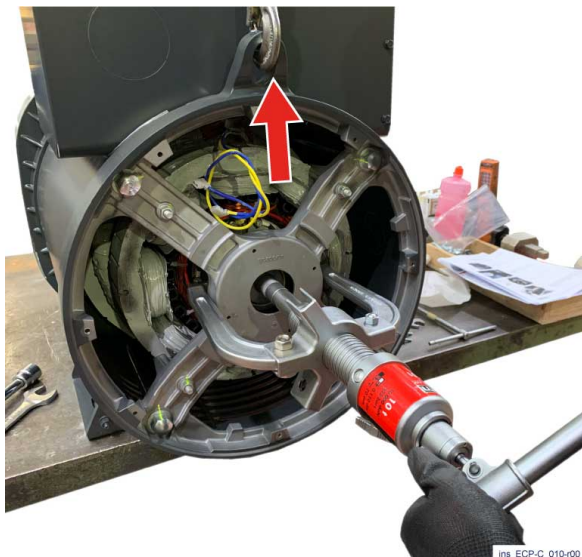

5) Tie the non drive end bracket with an opportune lifting system, insert an M16 screw in the threaded hole of the shaft and, using an extractor, push the shaft until the bearing is completely out from the N.D.E.



6) Remove the N.D.E. using a hammer and a aluminium or copper bar.



7) Extract the rotor pulling it manually. During this operation, position wood blocks under the disks, in order to sustain the rotor.

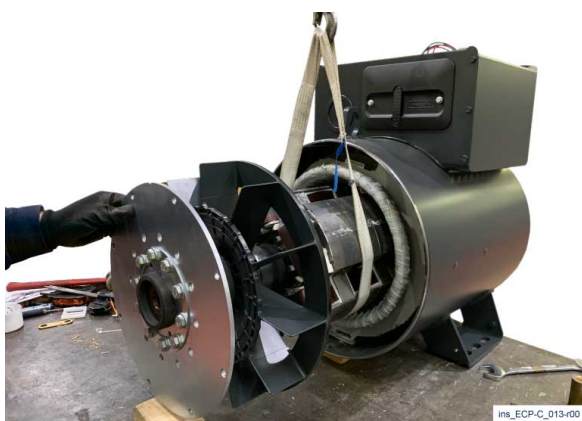

8) When possible position a soft rope in the rotor pack, and during the extraction of the rotor move the rope till it reach the equilibrium point. Lift the rotor and position it in a secure place.



9) Using an opportune extractor, remove the bearing from the shaft. Remove the exciter rotor using an arms puller.



10) Remove the screw of the exciter stator.



11) Using a leverage, remove the exciter stator.

9.5.4 Mechanical assembling

Reassembling bearings

Heat the bearings in an appropriate induction equipment.
Insert them into the shaft by pushing them to the end stop against the shoulder.



The heating temperature must not exceed the limit imposed by the manufacturer.

Rotor



Reassemble the rotor being very careful not to damage the windings.

Front Cover

To remove the front cover gently tap with a rubber hammer.

Back cover

During the assembling check the voltage of the exciter stator wires to avoid damaging them.

Fixing rod/bolts

To assemble the fixing rods and bolts use new washers and tighten them with the correct tightening torque.

In case of double-bearing alternators, once assembled, turn them manually to check whether there are impediments and anomalous noises.

In case of single-bearing alternators, this check must be carried out during the test, after the coupling with the drive motor.

Assembling Procedure

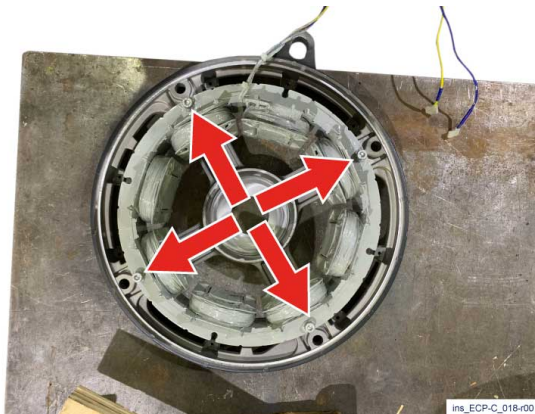

1) Place a new exciter stator on the N.D.E bracket legs with the yellow/blue wires positioned on the top part (see image on the side), then push the stator till the bracket with a soft hammer. Insert its screw and tighten it as 9.6.



2) Using a press, insert a new exciter rotor on the shaft. Alternatively it's possible to heat it till 110 °C and push it till the shaft shoulder. Pull the main rotor wires through the exciter rotor hole and fix it in the diode bridge with the correct polarity.



Caution

Using opportune anti-scald gloves.

Heat up the bearing till 110 °C.



See par. 9.4.1.



4) Using opportune anti-scald gloves, insert the bearing till the shaft shoulder.

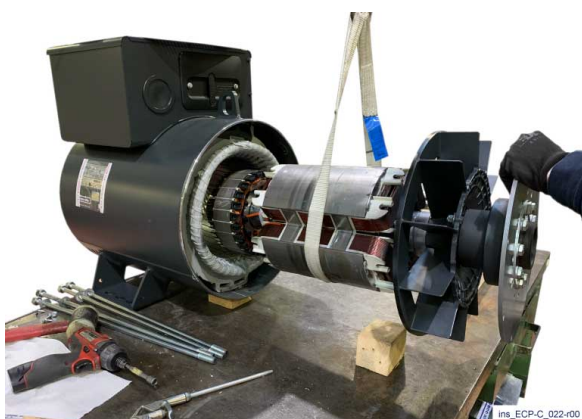

5) Lift the rotor using a soft rope, insert it in the stator and pull it till the stator and rotor pack are aligned.



6) Tie the non drive end bracket with an opportune lifting system, re-insert the yellow and blue wires through the apposite hole in the frame, then insert the non drive end bracket in its place.











7) Screwing a threaded bar in the threaded hole in the shaft and screw a nut in it, interposing an adequate flange between nut and non drive end bracket. Screw the nut till the bearing reach the the N.D.E. bracket shoulder.



8) Insert the drive end bracket matching the signs made previously, then insert the cover stay bolts. Finally, connect the blue and yellow cable on the regulator in the same previous position and fix it with cable tie. Then fix the rear grid and the cover of the terminal box.

9.5.5 Removal of disc holder hub (34 series)

Type of intervention 	Operator 	Periodicity 
PPE to wear     		Materials and equipments Workshop tools.

Danger



Disconnect the alternator from the power supplies. The drive motor must be off and unplugged from its power supplies.

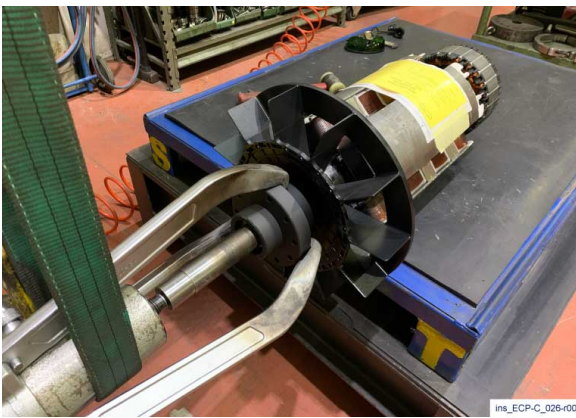

1) Remove flywheel from hub, mount an apposite hydraulic or pneumatic extractor and pressurize it.



2) Heat up the hub with an oxyacetylene torch, maintaining continuously pulling the extractor till the complete extraction of the hub.









Before reassembling the hub heat it to 250 °C for 1 hour.

Caution



Removing the hub using the torch (and therefore high temperatures) will damage the plastic fan, located immediately behind the hub. Therefore before replacing the hub it is also necessary to replace the fan; in this regard it is recommended to mark the position of any balancing weights applied on the fan so that, once the new fan has been replaced, the weights are reapplied in the same position on the fan and in the same position with respect to the rotating parts. This will allow for a balanced machine and proper cooling of the alternator during its operation.

9.5.6 Loss of residual magnetism (reexcitation of the machine)

Type of intervention 	Operator 	Periodicity 
PPE to wear 		Materials and equipments Battery, electrical wires and resistance.

Danger



Disconnect the alternator from the power supplies. The drive motor must be off and unplugged from its power supplies.



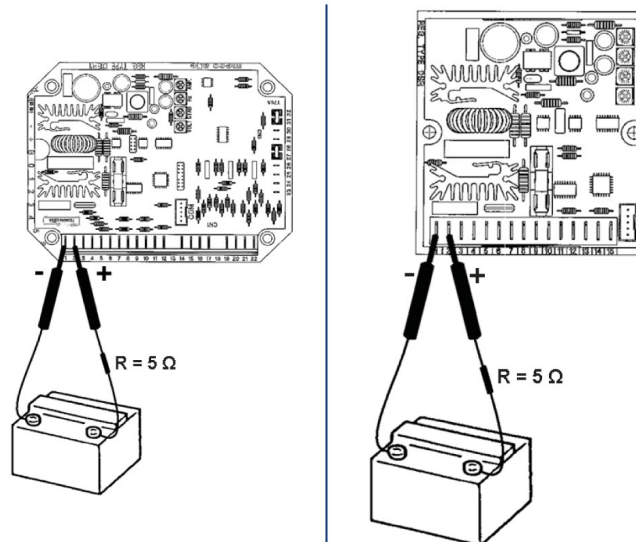

The following procedure applies to the alternators equipped with an electronic regulator and must be applied in case the alternator does not self-excite (in such case, even if rotating at nominal speed, voltage is not present in the main terminal block of the alternator):



lay_ECO_002-00

- With the alternator off, remove the cover of the terminal box.
- Prepare two terminals connected to a 12 Vdc battery possibly with a 5 Ω resistance in series.
- Use the electrical diagrams provided by Mecc Alte to identify the “+” and “-” terminals of the electronic regulator.
- Start the alternator.
- Apply for an instant the two terminals to the previously identified terminals being very careful to respect the polarity (“+” terminal of the regulator with the “+” terminal of the battery, “-” terminal of the regulator with the “-” terminal of the battery).
- Use a voltmeter or the corresponding board tools to check whether the alternator generates the nominal voltage indicated on the "nameplate" of the alternator.

9.5.7 Verification and replacement of voltage regulator

Type of intervention 	Operator 	Periodicity 
PPE to wear 		Materials and equipments Workshop tools.



Danger

Disconnect the alternator from the power supplies. The drive motor must be off and unplugged from its power supplies.

The alternators are equipped with an automated voltage regulator: the electronic regulators may be of 2 types: DSR, DER1. The standard supply comes with the DSR.



DER1 can be mounted on customer request.



In case there are voltage regulation problems not ascribable to an erroneous adjustment of the VOLT, STAB, Hz and AMP potentiometers and/or to the system (fully assembled machine + load), follow the procedure below for an in-depth check of the voltage regulator.

Visual Inspection of the Regulator



Do not change the position of the VOLT, STAB, Hz and AMP potentiometers before marking their position.

In particular check for:

- Mechanical damages of various kinds.
- State of fuses.
- Undamaged state of electrical connections.
- Potential presence of burned electrical components.
- Presence of the silicone protection in the Hz and AMP potentiometers.

Check the SCR resistance and flyback diode.

Before doing this test, check that the fuse is inserted and undamaged.

- Flyback diode: it is working if the diode test performed between pin 1 and 2 has a positive result.
- SCR: it is working if a resistance of some hundred K Ω is measured between pin 1 and 8 (in the DSR) or between pin 1 and 2 (in the DER1 regulator).

A resistance measure close to zero signals a SCR failure.

A reason for the damaging of these components may be the erroneous cabling of the alternator regulator.

Copy the data and alarms of the regulator.

To avoid creating new alarms, the copy of the data and alarms existing in the regulator (.dat and .alr files) must be made feeding the alternator with an appropriate continuous voltage, in accordance with the diagrams below.



The correct supply and operation of the software are signaled by a green LED flashing with a 1 second period. If the LED is not lit try to turn the power supply system off and restart it.

Testing on static bench (see paragraph 9.5.11, 9.5.12, and 9.5.13)

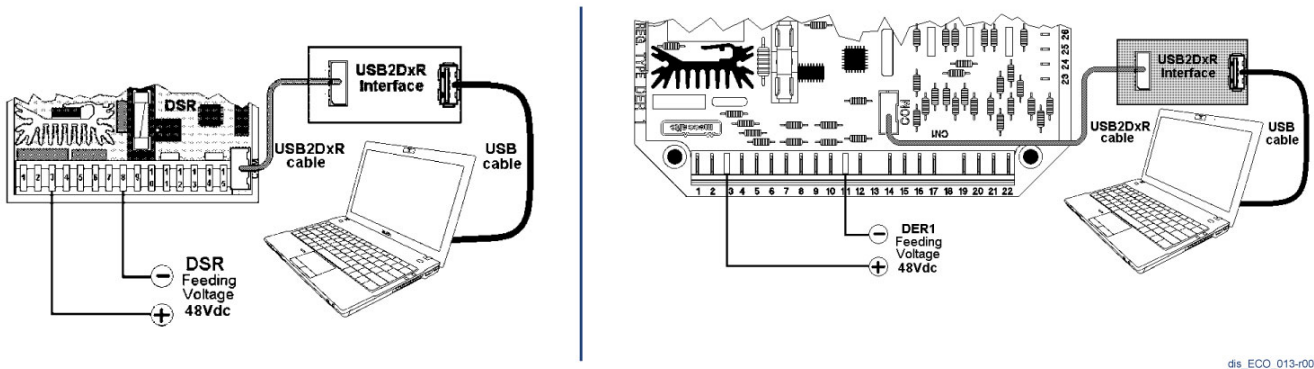

- Register the position of the VOLT, STAB, Hz and AMP potentiometers reading the L[32], L[33], L[34] and L[35] corresponding parameters and the state parameters, reading L[36], L[37], L[38] and L[39].
- Check the correct operation of the VOLT, STAB, Hz and AMP potentiometers, rotate them completely in anticlockwise and clockwise direction, the value of the L[32], L[33], L[34] and L[35] parameters must be 64 in one direction and 32760 in the other direction.
- Register the L[41] parameter; with the external potentiometer unconnected you should read a value of 16384; otherwise the external potentiometer circuit is damaged.
- Voltage regulation test: set the VOLT, STAB and Hz potentiometers to notch 6 then rotate the AMP potentiometer completely in clockwise direction. Read the L[43] and L[44] parameters.

When rotating the VOLT potentiometer in anticlockwise or in clockwise direction, the value of the L[43] parameter should respectively decrease or increase.

Check and confirm the following behavior: if the L[43] value is higher than the L[44] value, the bench light bulb should brighten. If instead the L[43] value is lower than the L[44] value, the light bulb should dim until it shuts off.

The light bulb represents the fictitious load connected between connectors 1 and 2 of the digital regulator.

- AMP protection test: set the STAB and Hz potentiometers to notch 6, then rotate the AMP potentiometer completely in clockwise direction; then rotate the VOLT potentiometer so as to have L[43] higher than L[44], the bench light bulb on and no active alarm.

Read the L[45] parameter and set the AMP potentiometer (reading the L[35] parameter for the SN equipped regulators with a yellow tag, or L[55] for the SN-equipped regulators with a blue tag, to a lower value than the value of the previously read L[45] parameter. Check the intervention of the AMP protection (alarm 5).

Once you established that the regulator must be replaced, proceed as follows:

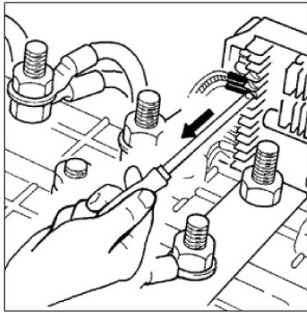

ins_ECO_004-r00

- Disconnect all the connection wires in the terminal block.
- Unscrew the blocking 2/4 screws of the regulator.

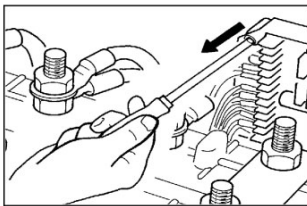





ins_ECO_005-r00

- Place the new regulator in the specified position.
- Fasten the new regulator with the previously collected screws.
- Reconnect all the wires to the terminal block of the regulator, using, if necessary, the diagrams provided by Mecc Alte.

In case you detect anomalous behavior please refer to the specific regulator manual or contact Mecc Alte's technical support service

9.5.8 DSR test and setup on test bench

Type of intervention 	Operator 	Periodicity 
PPE to wear 		Materials and equipments Personal computer+interface+software .

Danger



Disconnect the alternator from the power supplies. The drive motor must be off and unplugged from its power supplies. Disconnect the regulator and connect to a computer according to the diagrams below. The operations of functional checkout and parameter setting may be easier if they are performed on a test bench rather than with the regulator still inside the terminal box.

Caution



Given that some parts of the DSR which work with a high potential are not isolated, for the safety of the operator, it is necessary for the power source to be isolated from the electrical grid, for instance by a transformer.

Caution



The use of these types of connection is reserved to qualified personnel, able to assess the operational risks of high voltage and who have a full knowledge of the content of this manual.

The connection diagrams of the DSR and the USB2DxR communication interface are shown in figures (A), (B) or (C) in this paragraph based on the requested function and on the available supply voltage.

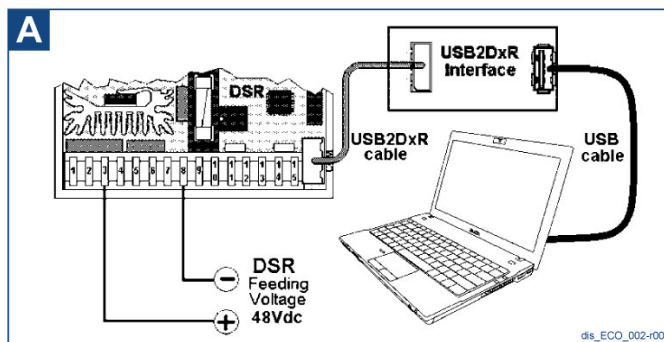

DSR 48Vdc power supply for the download of the alarms without risking to change to content of the EEPROM because of the tests.



No other connections besides the power supply are needed.

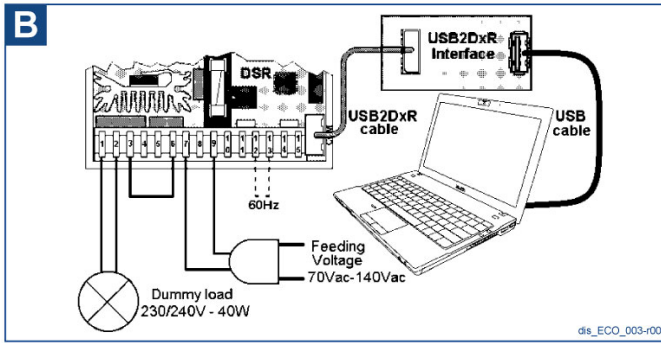

DSR 70-140Vac power supply for test and setup.



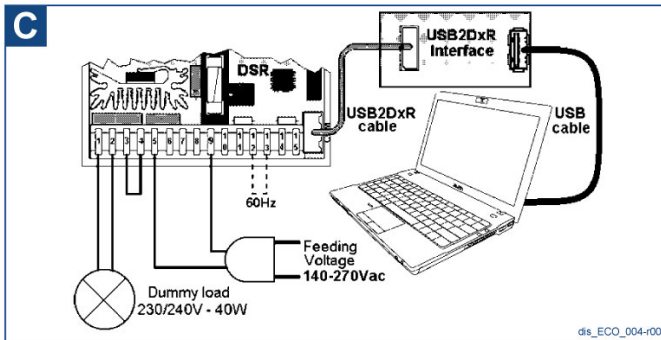

i The fictitious load between terminals 1 and 2, the sensing on terminal 7 and the bridge between terminals 6 and 3 of the DSR.



DSR 140-140Vac power supply for test and setup.

i The fictitious load between terminals 1 and 2, the sensing on terminal 5 and the bridge between terminals 3 and 4 of the DSR.

9.5.9 DER1 test and setup on test bench

Type of intervention 	Operator 	Periodicity 
PPE to wear 		Materials and equipments Personal computer+interface+software .

Danger



Disconnect the alternator from the power supplies. The drive motor must be off and unplugged from its power supplies. Disconnect the regulator and connect to a computer according to the diagrams below. The operations of functional checkout and parameter setting may be easier if they are performed on a test bench rather than with the regulator still inside the terminal box.

Caution



Given that some parts of the DER1 which work with a high potential are not isolated, for the safety of the operator, it is necessary for the power source to be isolated from the electrical grid, for instance by a transformer.

Caution



The use of these types of connection is reserved to qualified personnel, able to assess the operational risks of high voltage and who have a full knowledge of the content of this manual.

The connection diagrams of the DER1 and the USB2DxR communication interface are shown in figures (A), (B) or (C) in this paragraph based on the type of available power supplies.

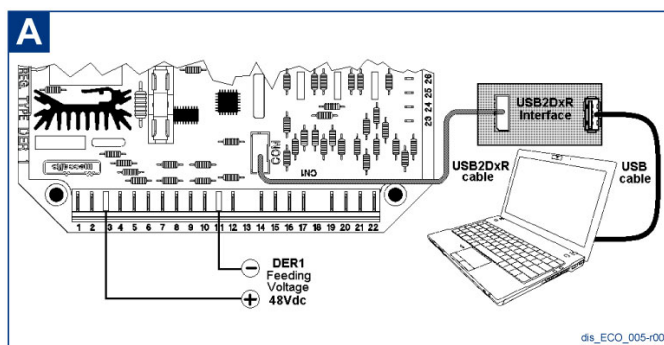

DER1 48Vdc power supply for the download of the alarms without risking to change to content of the EEPROM because of the tests.



No other connections besides the power supply are needed.

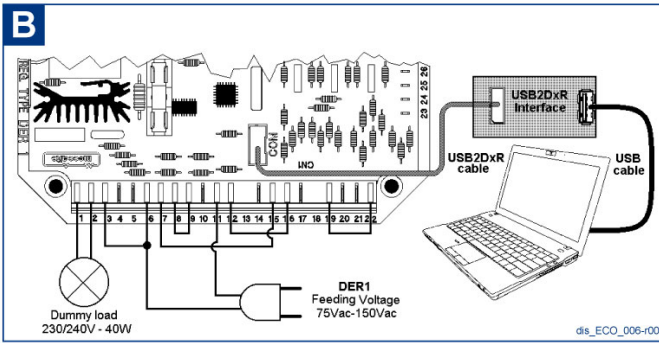

DER1 75-150Vac power supply for test and setup.



The fictitious load between terminals 1 and 2, the sensing on terminal 6 and the bridge between terminals 8 and 9, 7 and 15, 12 and 16, 19 and 22.

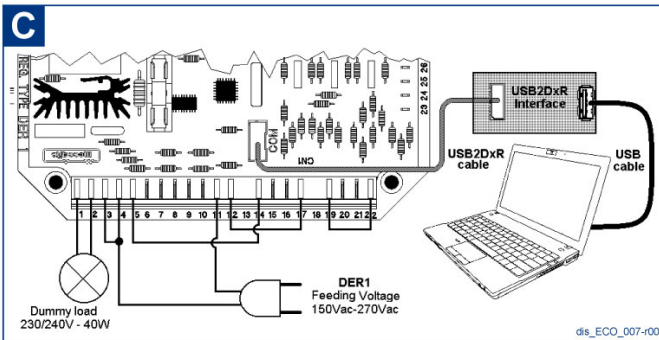





DER1 150-270Vac power supply for test and setup.



The fictitious load between terminals 1 and 2, the sensing on terminal 4 and the bridge between terminals 5 and 14, 12 and 17, 19 and 22.

9.5.10 Main stator windings voltage test

Type of intervention 	Operator 	Periodicity 
PPE to wear 		Materials and equipments Electrical tools.

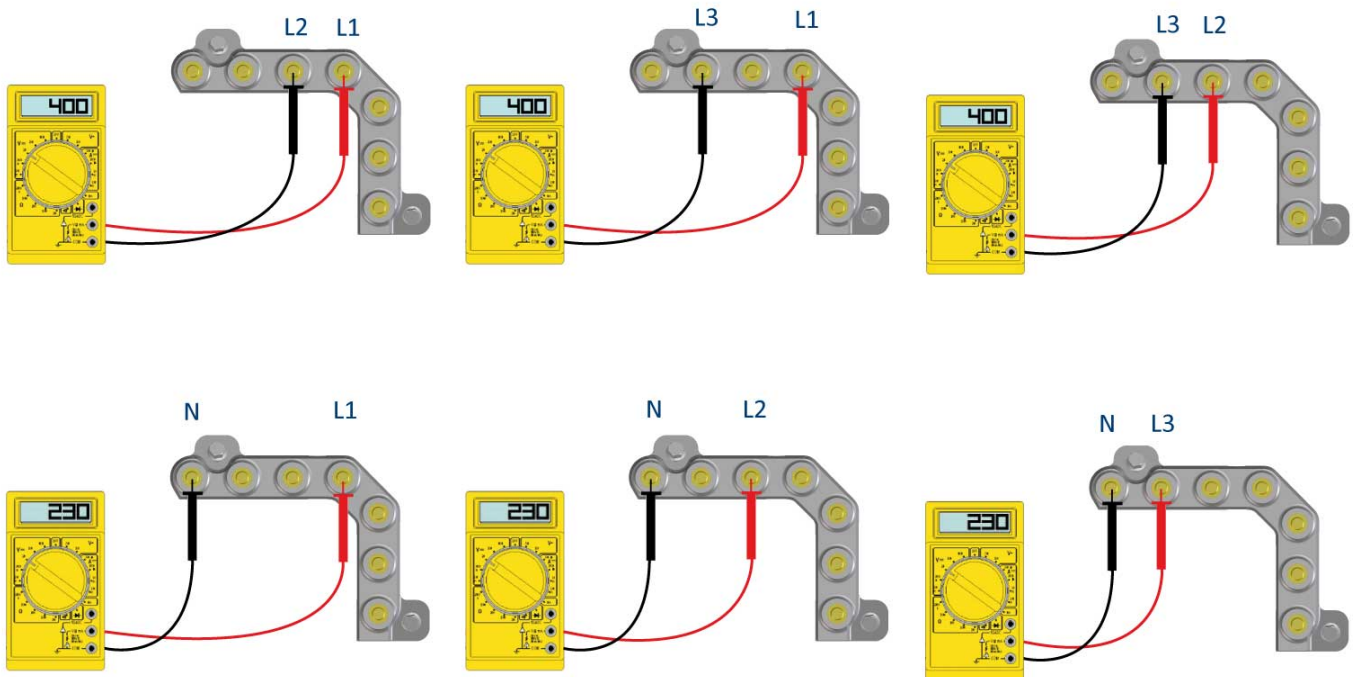

lay_ECP-C_003-r00

Use a multimeter to check all three phases (both L-L and L-N).

When off-load the voltage should be balanced on all three phases with a $\pm 1\%$ tolerance.

If the voltage is unbalanced, this indicates a problem in the main winding of the stator.

If instead the voltage is balanced on the three phases, then the winding of the stator does not have problems.

If the voltage is lower than 15% of the nominal voltage, there might be a problem with the regulator, in the rotating diode bridge or in the exciter winding.

9.5.10.1 Resistance/Continuity Test

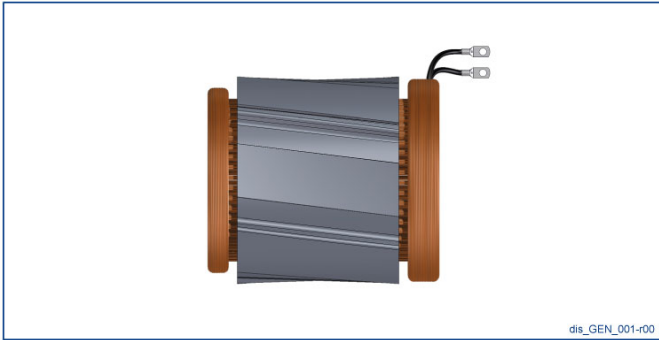

Main Stator

Use an appropriate tool to measure the phase resistance/continuity 1-2, 3-4, 5-6, 7-8, 9-10 and 11-12
Also check the resistance/continuity of the auxiliary winding between the two red wires coming out of the main stator.



For the values see paragraph 2.3.8

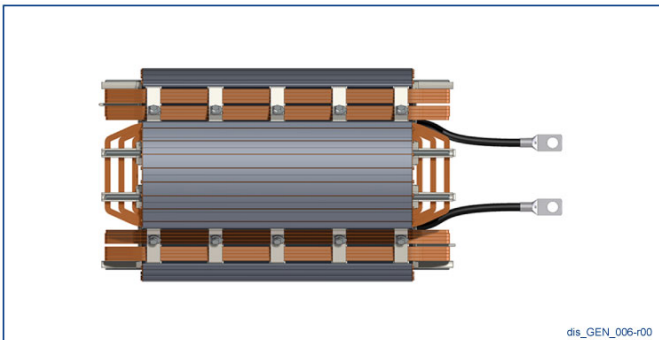

Main rotor

Measure the resistance/continuity of the main rotor using a multimeter.



For the values see paragraph 2.3.8

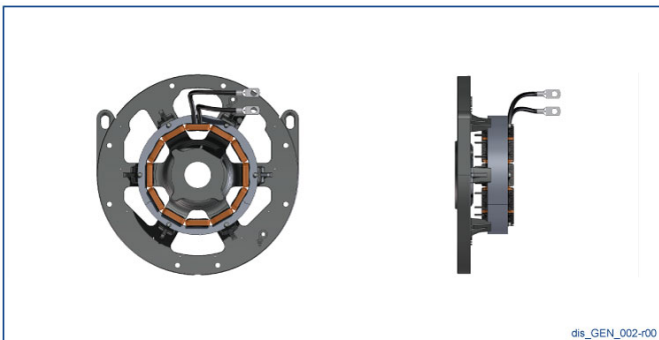

Exciter stator

Measure the resistance/continuity of the winding of the exciter stator between the positive wire (yellow) and the negative one (blue) with a multimeter.



For the values see paragraph 2.3.8

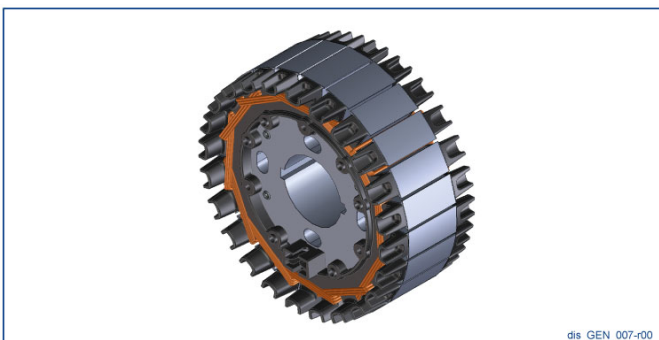

Exciter rotor

Measure the resistance/continuity of the winding of the exciter rotor between phases with a multimeter.



For the values see paragraph 2.3.8

9.5.10.2 Insulation Test

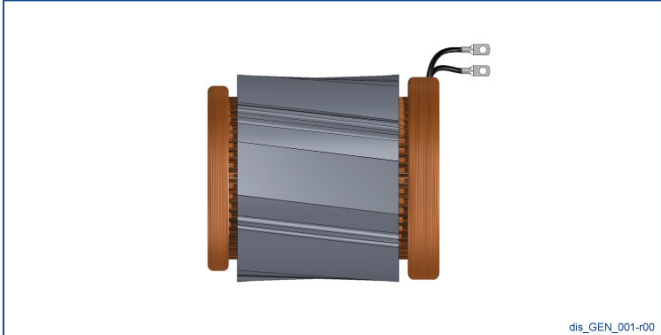

Main Stator

Completely disconnect the AVR and the connection between neutral and ground before performing this test.

The measurement must be carried out using an insulation tester (Megger) of 500 V.

Check the insulation between phases, between phases and ground, between auxiliary and phases and between auxiliary and ground.

i For these alternators, the minimum insulation value is of 5 MΩ.

If the insulation resistance is lower, the stator must be cleaned and, if necessary, impregnated or painted again with EG43 gray paint and then dried at 50-60 °C.

If after these operations the value remains low, the stator must be rewound or replaced.

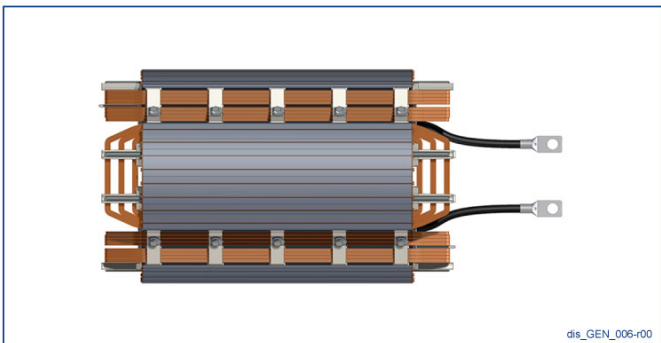

Main rotor

The insulation resistance is measured between phase and ground using an insulation tester (Megger).

i For these alternators, the minimum insulation value is of 5 MΩ.

If the insulation resistance is lower, the rotor must be cleaned and, if necessary, impregnated and then dried at 50-60 °C.

If after these operations the value remains low, the rotor must be rewound or replaced.

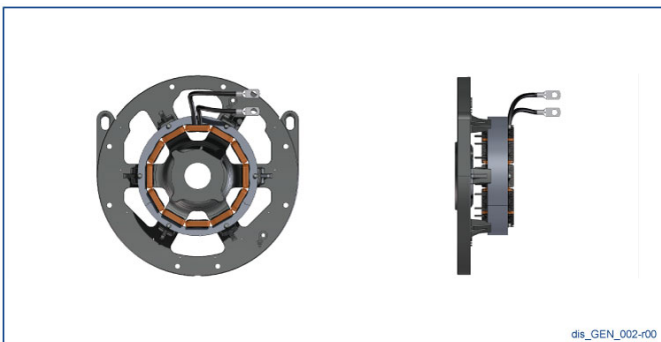

Exciter stator

The insulation resistance is measured between phase and ground using an insulation tester (Megger).

i For these alternators, the minimum insulation value is of 5 MΩ.

If the insulation resistance is lower, the stator must be cleaned and, if necessary, painted again with EG43 gray paint and then dried at 50-60 °C.

If after these operations the value remains low, then the stator must be rewound or replaced.

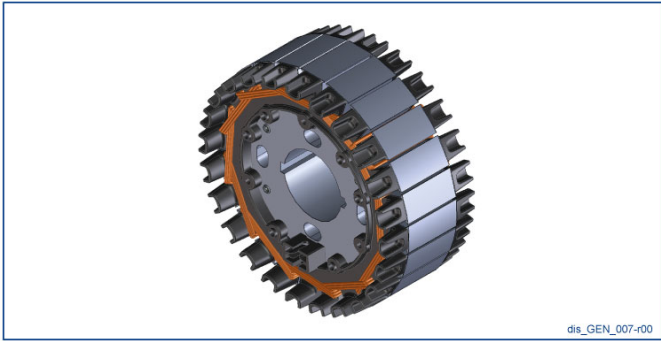

Exciter rotor

The insulation resistance is measured between phase and ground using an insulation tester (Megger).



For these alternators, the minimum insulation value is of 5 M Ω .

If the insulation resistance is lower, the rotor must be cleaned and, if necessary, impregnated and then dried at 50-60 °C.

If after these operations the value remains low, the rotor must be rewound or replaced.

9.6 General Tightening Torques

9.6.1 ECP4 C Series

Application		Screw type		[Nm] ± 7% Tightening Torque	Replacement parts cat. reference
Cover tie rod	M	M8 X 335		21	8
	L	M8 X 402		21	
Fastening of 30 mm exciter stator		M6 X 80	CL. 8.8	7	7
IP2X protection of front cover		M5 X 25	CL. 4.8	3.3	/
Rear Grid		M6 X 16	CL. 6.8	9	/
Terminal Board		M6 X 16	CL. 8.8	9	/
Fastening the terminal block to the frame		M6 X 16	CL. 8.8	2.5	/
Closed side panel fixing		M6 X 25	CL. 8.8	2.5	/
Regulator side panel fixing		M6 X 25	CL. 8.8	6	/
Regulator plug fixing		M6 X 10	CL. 8.8	6	/
Terminal box cover fixing		M6 X 16	CL. 8.8	9	/
Ground terminal on the frame		M6 X 16	CL. 8.8	9	/
Ground terminal on the cover		M6 X 25	CL. 8.8	9	/
Clamp for fan fastening		M8 X 30	CL. 8.8	12.5	17
Regulator		M4 X 25	CL. 4.8	1.5	/
Flywheel					
Flywheel 6.5		M8 X 25	CL. 8.8	25	14
Flywheel 7.5		M8 X 25	CL. 8.8	25	14
Flywheel 8		M8 X 55	CL. 8.8	25	14
Flywheel 10		M8 x 50	CL. 8.8	25	14
Flywheel 11.5		M8 x 35	CL. 8.8	25	14

Optional				
Parallel device fastening	M5 X 12	CL. 4.8	1.5	/
Terminal board for parallel device	M3 X 16	CL. 8.8	1.5	/
Terminal board for accessories	M3 X 20	CL. 4.8	0.5	/
Spacing insulator	M6 X 10	CL. 4.8	7	/

9.6.2 ECP28 C Series

Application		Screw type		[Nm] ± 7% Tightening Torque	Replacement parts cat. reference
Cover tie rod	VS	M8 X 299		21	8
	S	M8 X 338		21	
	M	M8 X 358		21	
	L	M8 X 393		21	
	VL	M8 X 438		21	
Fastening of 35 mm exciter stator		M6 X 95	CL. 8.8	9	7
IP2X protection of front cover		M5 X 10	CL. 4.8	3.3	9
Rear Grid		M6 X 16	CL. 8.8	9	1
Terminal Board		M6 X 16	CL. 8.8	9	/
Fastening the terminal block to the frame		M6 X 16	CL. 8.8	9	/
Closed side panel fixing		M6 X 16	CL. 8.8	9	/
Regulator side panel fixing		M6 X 16	CL. 8.8	9	/
Regulator plug fixing		M6 X 10	CL. 8.8	6	/
Terminal box cover fixing		M6 X 16	CL. 8.8	9	/
Ground terminal on the frame		M6 X 16	CL. 8.8	9	/
Ground terminal on the foot		M6 X 25	CL. 8.8	9	/
Clamp for fan fastening		M8 X 30	CL. 8.8	12.5	16
Regulator		M4 X 25	CL. 4.8	1.5	/
Flywheel					
Flywheel 6.5		M10 X 30	CL. 8.8	48	14
Flywheel 7.5		M10 X 30	CL. 8.8	48	14
Flywheel 8		M10 X 30	CL. 8.8	48	14
Flywheel 8		M12 X 30	CL. 8.8	80	14
Flywheel 10		M10 X 30	CL. 8.8	48	14
Flywheel 10		M12 X 30	CL. 8.8	80	14
Flywheel 11.5		M10 X 40	CL. 8.8	48	14

Optional				
Parallel device fastening	M4 X 10	CL. 4.8	1.5	/
Terminal board for parallel device	M4 X 25	CL. 4.8	0.5	/
Terminal board for accessories	M3 X 20	CL. 4.8	0.5	/
Spacing insulator	M6 X 10	CL. 4.8	7	/

9.6.3 ECP30 C Series

Application		Screw type		[Nm] ± 7% Tightening Torque	Replacement parts cat. reference
Cover tie rod	M	M8 X 398		17	8
	L	M8 X 460		17	
Fastening of 35 mm exciter stator		M6 X 95	CL. 8.8	9	7
IP2X protection of front cover		M5 X 25	CL. 4.8	3.3	/
Rear Grid		M6 X 16	CL. 8.8	9	/
Terminal Board		M6 X 16	CL. 8.8	9	/
Fastening the terminal block to the frame		M6 X 16	CL. 8.8	9	/
Closed side panel fixing		M6 X 16	CL. 8.8	9	/
Regulator side panel fixing		M6 X 16	CL. 8.8	9	/
Regulator plug fixing		M6 X 10	CL. 8.8	6	/
Terminal box cover fixing		M6 X 16	CL. 8.8	9	/
Ground terminal on the frame		M6 X 16	CL. 8.8	9	/
Ground terminal on the foot		M6 X 25	CL. 8.8	9	/
Clamp for fan fastening		M8 X 30	CL. 8.8	12.5	16
Regulator		M4 X 25	CL. 4.8	1.5	/
Flywheel					
Flywheel 6.5		M10 X 30	CL. 8.8	48	14
Flywheel 7.5		M10 X 30	CL. 8.8	48	14
Flywheel 8		M10 X 30	CL. 8.8	48	14
Flywheel 8		M12 X 30	CL. 8.8	80	14
Flywheel 10		M10 X 30	CL. 8.8	48	14
Flywheel 10		M12 X 30	CL. 8.8	80	14
Flywheel 11.5		M10 X 40	CL. 8.8	48	14

Optional				
Parallel device fastening	M4 X 10	CL. 4.8	1.5	/
Terminal board for parallel device	M4 X 25	CL. 4.8	0.5	/
Terminal board for accessories	M3 X 20	CL. 4.8	0.5	/
Spacing insulator	M6 X 10	CL. 4.8	7	/

9.6.4 ECP32 C Series

Application		Screw type		[Nm] ± 7% Tightening Torque	Replacement parts cat. reference
Cover tie rod	S/2	M10 X 438		34	8
	S/4	M10 X 427		34	
	M/4	M10 X 492		34	
	L/2-4	M10 X 573		34	
Fastening of 45 mm exciter stator (S/M)		M6 X 122	CL. 6.8	9	7
IP2X protection of front cover		M5 X 25	CL. 4.8	3.3	/
Rear Grid		M6 X 16	CL. 8.8	9	/
Terminal board		M6 X 20	CL. 8.8	6	/
Fastening the terminal box to the frame		M6 X 16	CL. 8.8	9	/
Terminal box		M5 X 12	CL. 8.8	3.5	/
Regulator support fastening		M5 X 12	CL. 8.8	3.5	/
Frame ground		M6 X 16	CL. 8.8	9	/
Foot ground		M6 X 16	CL. 4-5	9	/
Rotor V-square (for 4 pole only)		M5 X 35	CL. 8.8	3.5	/
Clamp for fan fastening		M8 X 30	CL. 8.8	12.5	16
Regulator		M4 X 20	CL. 4.8	1.5	/
Flywheel					
Flywheel 6.5		M12 X 35	CL. 12.9	140 ± 10%	14
Flywheel 7.5		M12 X 35	CL. 12.9	140 ± 10%	14
Flywheel 8		M12 X 35	CL. 12.9	140 ± 10%	14
Flywheel 8		M12 X 30	CL. 8.8	80	14
Flywheel 10		M12 X 35	CL. 12.9	140 ± 10%	14
Flywheel 10		M12 X 30	CL. 8.8	80	14
Flywheel 11.5		M12 X 40	CL. 12.9	140 ± 10%	14

Optional				
Parallel device fastening	M4 X 10	CL. 4.8	1.5	/
Terminal board for parallel device	M3 X 16	CL. 4.8	0.5	/
Terminal board for accessories	M3 X 16	CL. 4.8	0.5	/
Spacing insulator	M8 X 12	CL. 4.8	21	/
Noise filter radio	M4 X 20	CL. 4.8	1.5	/
Front air filter IP45	M5 X 16	CL. 8.8	3.5	/
	M6 X 30	CL. 8.8	9	/
Rear air filter IP45	M6 X 14	CL. 8.8	9	/

9.6.5 ECP34 C Series

Application	Screw type		[Nm] ± 7% Tightening Torque	Replacement parts cat. reference
Cover tie rod S	M14 X 540		120 ± 10%	8
Cover tie rod M	M14 X 580		120 ± 10%	8
Cover tie rod L	M14 X 635		120 ± 10%	8
Fastening of 55 mm exciter stator	M8 X 140		25	7
IP2X protection of front cover	M5 X 25	CL. 4.8	3.3	/
Rear cover	M6 X 16	CL. 8.8	9	/
Terminal board	M8 X 20	CL. 8.8	21	/
Fastening the terminal box to the frame	M6 X 16	CL. 8.8	9	/
Terminal box	M6 X 16	CL. 8.8	9	/
Regulator plug with screwdriver	M6 X 10	CL. 8.8	9	/
Ground terminal on the frame	M6 X 16	CL. 8.8	9	/
Ground terminal on the foot	M8 X 25	CL. 8.8	21	/
Fan fastening	M8 X 30	CL. 8.8	12.5	16
Regulator	M4 X 25	CL. 4.8	1.5	/
Flywheel				
Flywheel 10	M10 X 30	CL. 8.8	48	14
Flywheel 11.5	M10 X 45	CL. 8.8	48	14
Flywheel 14	M10 X 30	CL. 8.8	48	14
Optional				
Parallel device fastening	M4 X 16	CL. 4.8	1.5	/
Terminal board for parallel device	M4 X 25	CL. 4.8	1.5	/
Terminal board for accessories	M3 X 20	CL. 4.8	0.5	/
Spacing isolator	M6 X 16	CL. 8.8	7	/
Terminal board for optional	M6 X 16	CL. 4.8	9	/
Jumper for PTS	M5 X 16		1.7	/
	M5 X 12		1.7	/

9.7 Disc Tightening Torques

In case of replacement of discs, the appropriate tightening torques are indicated here (fastening discs to hub).

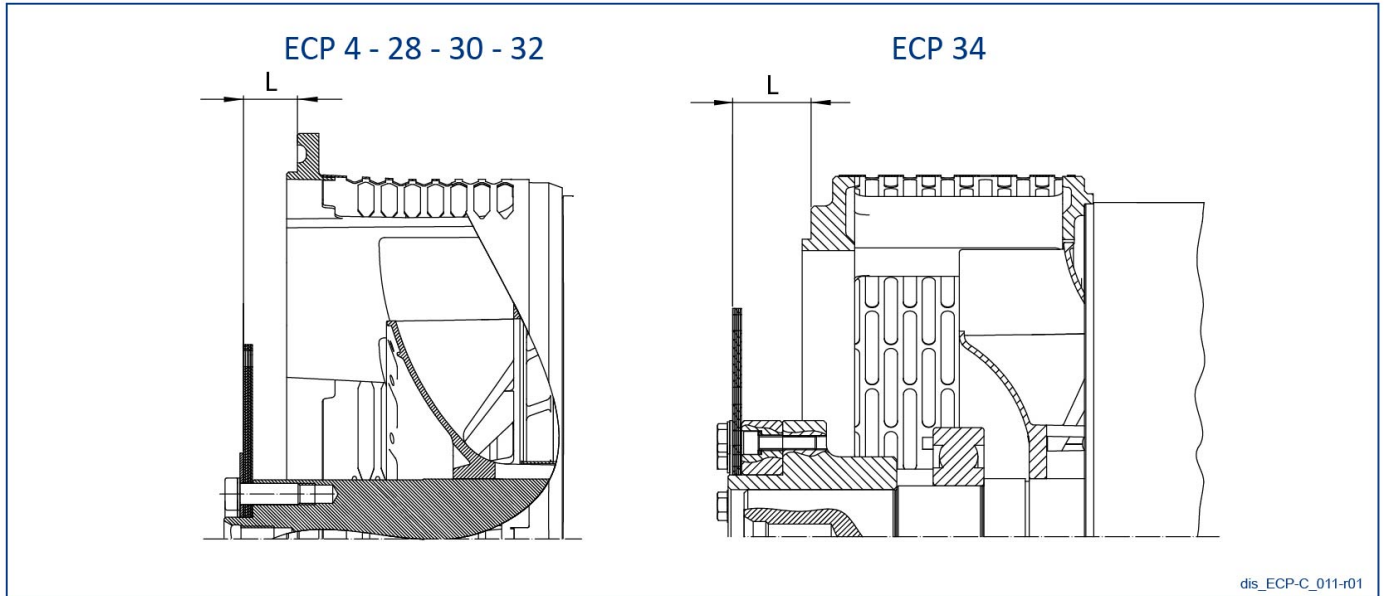

dis_ECP-C_011-r01

Type	SAE	L	Screw size		Tightening Torques (Nm)	
			TE	TCCEI	CL. 8.8	CL. 12.9
ECP4	6 ½	30.2	/	M8x25-8.8	25 ± 7%	/
	7 ½	30.2	/	M8x25-8.8	25 ± 7%	/
	8	62	/	M8x55-8.8	25 ± 7%	/
	10	53.8	/	M8x50-8.8	25 ± 7%	/
	11 ½	39.6	/	M8x35-8.8	25 ± 7%	/
ECP28	6 ½	30.2	M10x30-8.8	/	48 ± 7%	/
	7 ½	30.2	M10x30-8.8	/	48 ± 7%	/
	8	62	M12x30-8.8	M10x30-8.8	80-48 ± 7%	/
	10	53.8	M12x30-8.8	M10x30-8.8	80-48 ± 7%	/
	11 ½	39.6	M10x40-8.8	/	48 ± 7%	/
ECP30	6 ½	30.2	M10x30-8.8	/	48 ± 7%	/
	7 ½	30.2	M10x30-8.8	/	48 ± 7%	/
	8	62	M12x30-8.8	M10x30-8.8	80-48 ± 7%	/
	10	53.8	M12x30-8.8	M10x30-8.8	80-48 ± 7%	/
	11 ½	39.6	M10x40-8.8	/	48 ± 7%	/
ECP32	6 ½	30.2	/	M12x40-12.9	/	140 ± 10%
	7 ½	30.2	/	M12x40-12.9	/	140 ± 10%
	8	62	M12x30-8.8	M12x40-12.9	80 ± 7%	140 ± 10%
	10	53.8	M12x30-8.8	M12x40-12.9	80 ± 7%	140 ± 10%
	11 ½	39.6	/	M12x40-12.9	/	140 ± 10%
ECP34	10	53.8	M10x30-8.8	M10x40-8.8	48 ± 7%	/
	11 ½	39.6	M10x45-8.8	/	48 ± 7%	/

	14	25.4	M10x30-8.8	/	48 ± 7%	/
--	----	------	------------	---	---------	---

9.8 Terminal block Tightening Torques

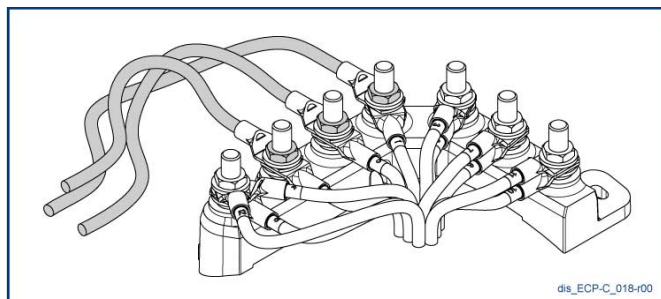

THREAD DIAMETER Df	TYPE	TIGHTENING TORQUE (Nm)
M6	ECP28	$6 \pm 7\%$
M8	ECP32	$9 \pm 7\%$
M12	ECP34	$21 \pm 7\%$

10 DSR / DER1 alarm management

The state of the active alarms is visualized at location 38 that may be read through USB.

The index of the bits that present value 1 correspond to an active alarm.

If the regulator is working regularly (no active alarm) the B11 bit will result active.

N.	Event description	Action
1	EEprom Checksum	Restoring default data, Block
2	Overtoltage	APO
3	Undervoltage	APO
4	Short circuit	APO, Maximum current, Block
5	Excitation Overcurrent	APO, Reduction of Excitation Current
6	Low speed	APO, V/F Ramp
7	Overspeed	APO
8	Underexcitation /loss of excitation	APO

During normal operation a LED indicator mounted on the card flashes with a 2 second period and 50% duty cycle.

In case of intervention or signaling of any alarm there are different flashing modes available, as shown in the figure below.

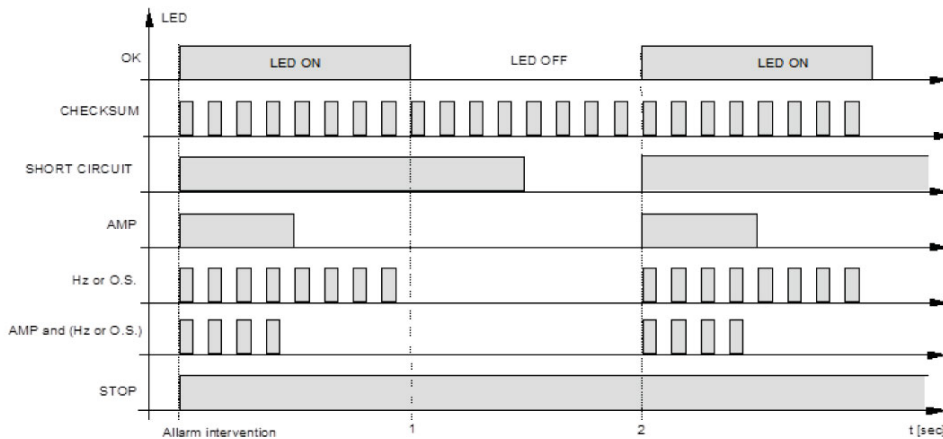

dis_ECO_012-r00

10.1 DSR/DER1 digital regulator alarms

ALARM DESCRIPTION		
N.	Event description	Action
1	Erroneous EEPROM control code	It is checked on start (after the DSP reset and the launch of the peripheral devices). The actions taken are: signaling, loading default settings, saving in EEPROM and blocking the regulator. Upon restart, if EEPROM is faulty, the alarm will be repeated, otherwise the regulator will start to operate on default parameters.
2	Overvoltage	The alarm does not determine a change in the LED flash, enables APO output and is memorized. It may be caused either by anomalous operating conditions (such as overspeed or capacitive load) or by any fault in the regulator. The overvoltage alarm is activated only if the angle has already been reduced to zero and, therefore, output voltage control has been lost. Overvoltage is calculated using an appropriate window, based on the speed and it is inhibited during the transients, for 2 sec. In the calculation window the threshold is set to 5% above the nominal value.
3	Undervoltage (@ ωN)	The alarm does not determine a change in the LED flash, enables APO output and is memorized. Undervoltage is calculated using an appropriate window based on the speed (visible in the undervoltage alarm description), the threshold is set to 5% under the nominal value; it intervenes only above the intervention threshold of the low speed alarm, it basically is inhibited by it. It is also inhibited in case of intervention of the "excitation overcurrent" alarm and during transients.
4	Short circuit	The alarm is disabled under 20Hz and visualized and memorized when action is activated. Tolerated short circuit time goes from 0.1 to 25,5 seconds (programmable in 100ms steps); then the regulator, after having saved DD and TT, turns to block mode and signals the STOP status. With the "short circuit time" parameter set to zero, the block is disabled. The reduction of the angle may cause an excitation drop, with a consequent stop and subsequent restart of the regulator and then the cycle is repeated.
5	Excitation Overcurrent	This alarm's function is not only to signal a state of excess accumulation of heating of the exciter, but also an active function of elimination of the cause. There is in fact a regulation ring that takes over after a threshold is exceeded; the action determines the reduction of the excitation current and then of the output voltage. The available parameter is the "threshold", which determines, in the end, the balance value at which the system stabilizes. The alarm is signaled and memorized. For the adjustment see paragraph "Excitation overcurrent".
6	Low speed	(Immediate) Signaling and activation of the V/F ramp. This alarm also appears at start and at stop. The alarm does not trigger data saving in EEPROM. The alarm intervention threshold depends on the 50/60 jumper status (hardware or software) and on the Hz trimmer position or on the value of parameter 21. Under the threshold the V/F ramp is present.

ALARM DESCRIPTION		
N.	Event description	Action
7	Overspeed	It is visualized similarly to the low speed alarm, it does not trigger actions on control and it is memorized. The overspeed condition may cause, as in the case of capacitive load, an overvoltage. The threshold may be set through parameter 26.
8	Underexcitation /loss of excitation	The alarm does not determine a change in the LED flash, enables APO output and is memorized. The alarm condition is recognized by a underexcitation / loss of excitation observer, available for reading at location L[56]: if the value of L[56] is higher than the upper (fixed) threshold or lower than the value of the lower threshold (parameter P[27]), A-08 is activated. The alarm is inhibited during transients.

11 Problems, causes and solutions

Defect	Cause	Remedies
The alternator does not excite.	Faulty fuse.	Check the fuse and if necessary replace it.
	Faulty diodes.	Check the diodes and if necessary replace them (see paragraph 9.5.2).
	Speed too low (lower than nominal speed).	Adjust the speed to the nominal value.
	Residual magnetism too low.	Apply for an instant to the "+" and "-" of the electronic regulator a voltage of 12V of a battery with in series a resistance of 30 ohms, respecting the polarities.
The alternator de-excites after excited state.	Connection cables damaged or disconnected.	Check the state and correct fastening of cables. Check the correct connection of cables using the attached drawings.
At no load low voltage	Regulator is not adjusted.	Readjust the voltage and/or stability. (see paragraph 8.1 and 8.2).
	Faulty regulator.	Replace the regulator.
	Speed lower than nominal speed.	Check the number of rotations.
	Damaged windings.	Check windings. (see paragraph 9.5.10).
At no load voltage is too high.	Regulator is not adjusted.	Readjust the voltage and/or stability (see paragraph 8.1 and 8.2).
	Faulty regulator.	Replace the regulator.
At load, voltage is lower than nominal voltage.	Regulator is not adjusted.	Readjust the voltage and/or stability (see paragraph 8.1 and 8.2).
	Faulty regulator.	Replace the regulator.
	Current is too high, $\cos \phi$ lower than 0.8, speed lower than 4% nominal speed.	Operating outside the standard parameter range. Adjust the alternator back to standard parameters.
	Faulty diodes.	Check the diodes and if necessary replace them (see paragraph 9.5.2).
At load, voltage is higher than nominal voltage.	Regulator is not adjusted.	Readjust the voltage and/or stability (see paragraph 8.1 and 8.2).
	Regulator is not adjusted.	Replace the regulator.

Defect	Cause	Remedies
Unstable voltage.	Instability of the drive motor rotation speed.	Check uniformity of the drive motor rotation speed.
	"STAB" potentiometer of the regulator not adjusted.	Adjust stability of the regulator by turning the "STAB" potentiometer. (see paragraph 8.1.1 and 8.2.1).
Bearing high temperature	Damaged bearing.	Replace the bearing (see paragraph 9.5.3).
	Shaft Misalignment.	Check alignment (see paragraph 5.3.2 and 5.3.3).
Temperature of cooling air is high.	Ambient temperature is high.	Check the ventilation in the room to ensure correct temperature.
	Air backflow towards the machine.	Check for presence of obstructions around the machine.
	Aspiration of obstructed area.	Check the air vents.
	Heat source nearby the air vents.	Move heat source or machine.
	Air filter is clogged.	Clean or replace the air filter (see paragraph 9.3.2).
Vibration	Damaged bearings.	Replace bearings (see paragraph 9.5.3).
	Unbalancing/break of cooling fan.	Check/replace cooling fan (see paragraph 9.5.1).
	Inefficient base-attachment system.	Check attachment system.
	Misalignment between alternator and drive motor.	Check alignment between alternator and drive motor (see paragraph 5.3.2 and 5.3.3).



For any other anomaly please contact the reseller, in the authorized service centers or directly at Mecc Alte.

12 Electrical diagrams

Regulator type	Connection	Drawing No.
DSR	12 terminals - single-phase reference	SCC0062
DSR	12 terminals - single-phase reference	SCC0063
DSR	12 terminals - single-phase reference	SCC0064
DER1	12 terminals - single-phase reference	SCC0161
DER1	12 terminals - single-phase reference	SCC0160
DER1	12 terminals - three-phase reference	SCC0159
DER1	12 terminals - three-phase reference	SCC0158
DER1	12 terminals - single-phase reference	SCC0202
DER1	12 terminals - ZIG-ZAG connection, single-phase reference	SCC0203
SR7	6 terminals - single-phase reference	A2544
UVR6	6 terminals - single-phase reference	A2550
SR7	12 terminals - single-phase reference	A2545
UVR6	12 terminals - single-phase reference	A2549
UVR6	6 terminals - three-phase reference	A2548
UVR6	12 terminals - three-phase reference	A2552

12.1 DSR digital regulator electrical diagrams

SCC0062: Alternators with 12 terminals with reference on half phase from 70 V to 140 V.

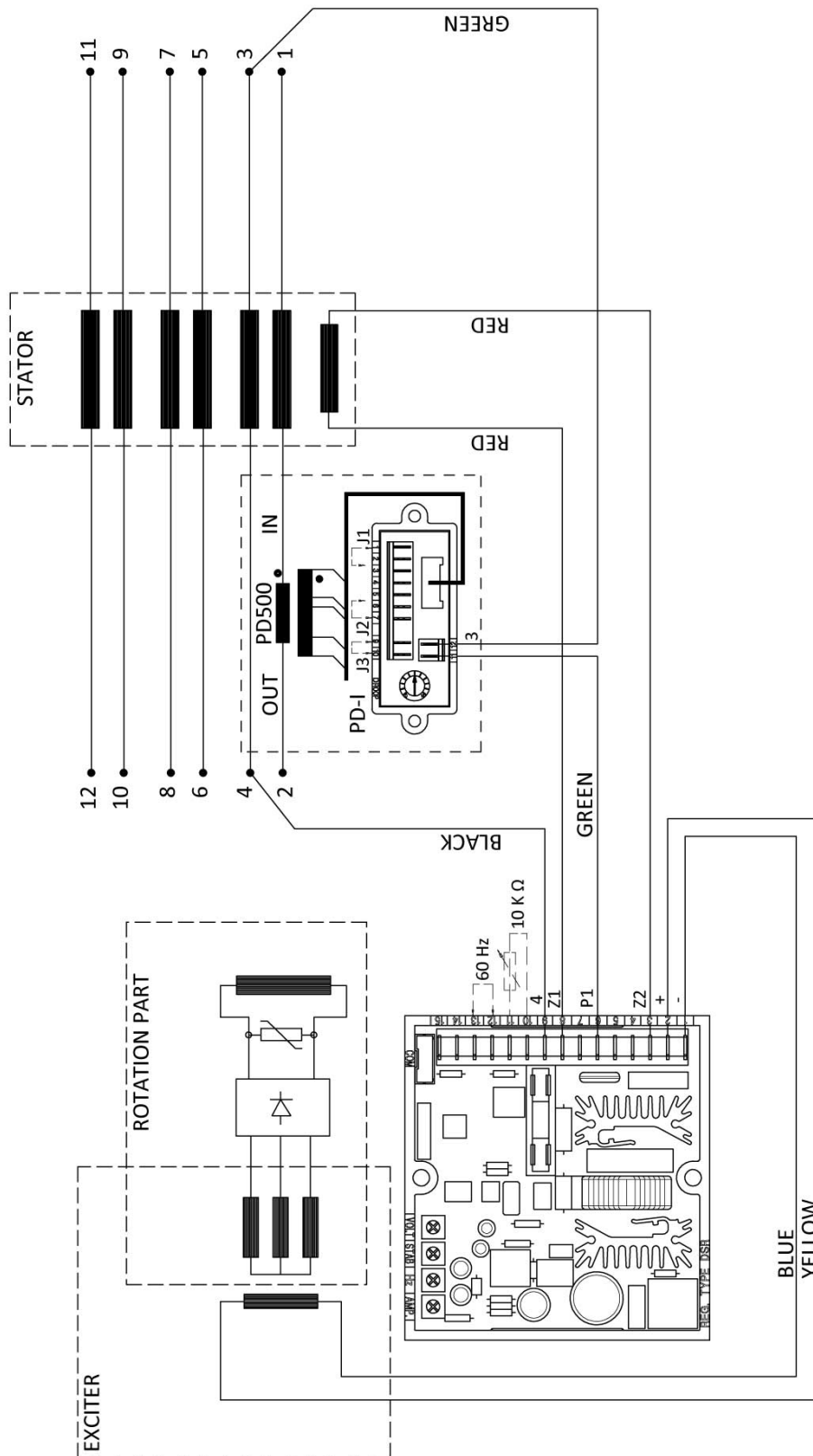

sd1_SCC0062-00_001-r00

SCC0063: Alternators with 12 terminals for star or delta connections, reference on the entire phase from 140 V to 280 V.

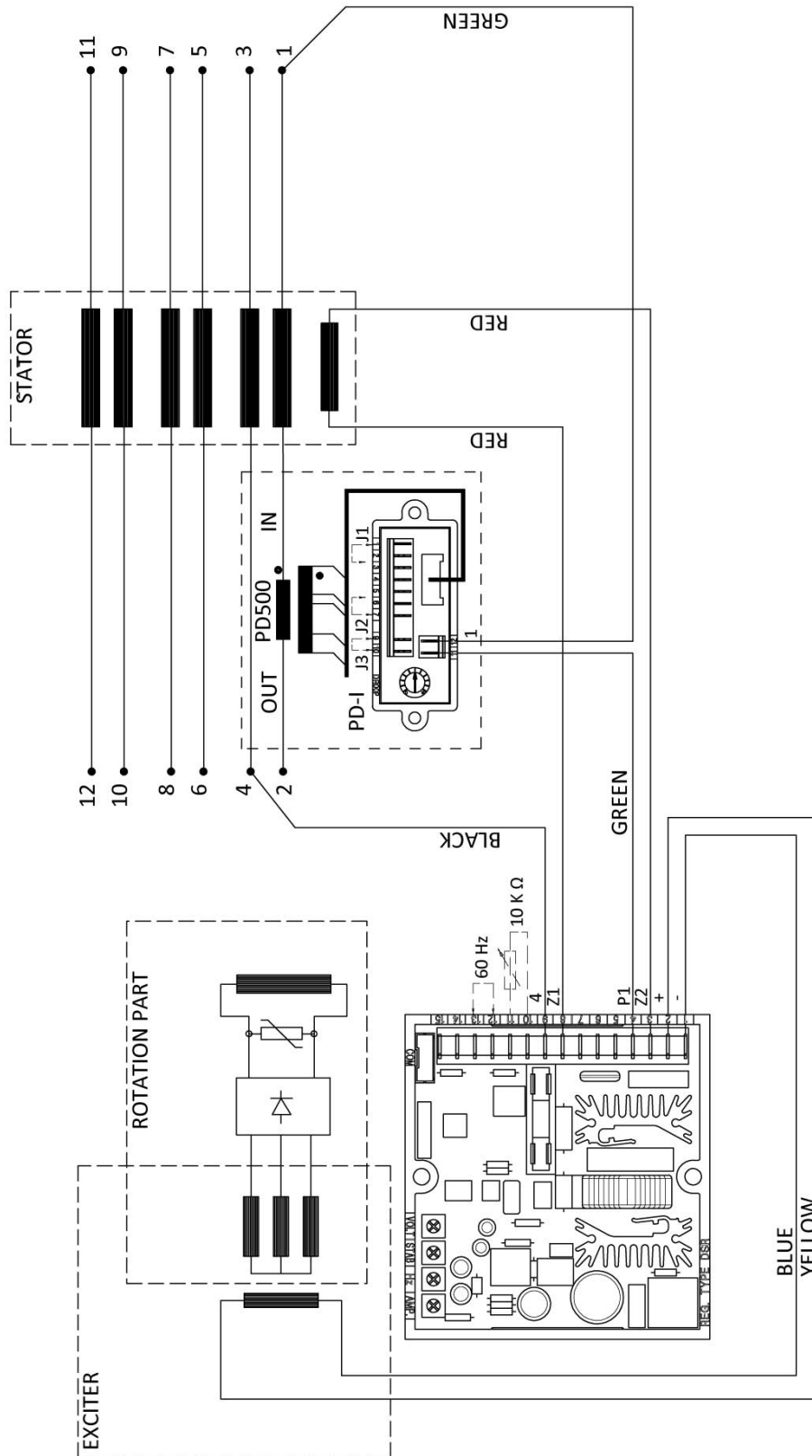

sch_SCC0063-03_001-00

SCC0064: Alternators with 12 terminals with reference on half phase from 140 V to 280 V.

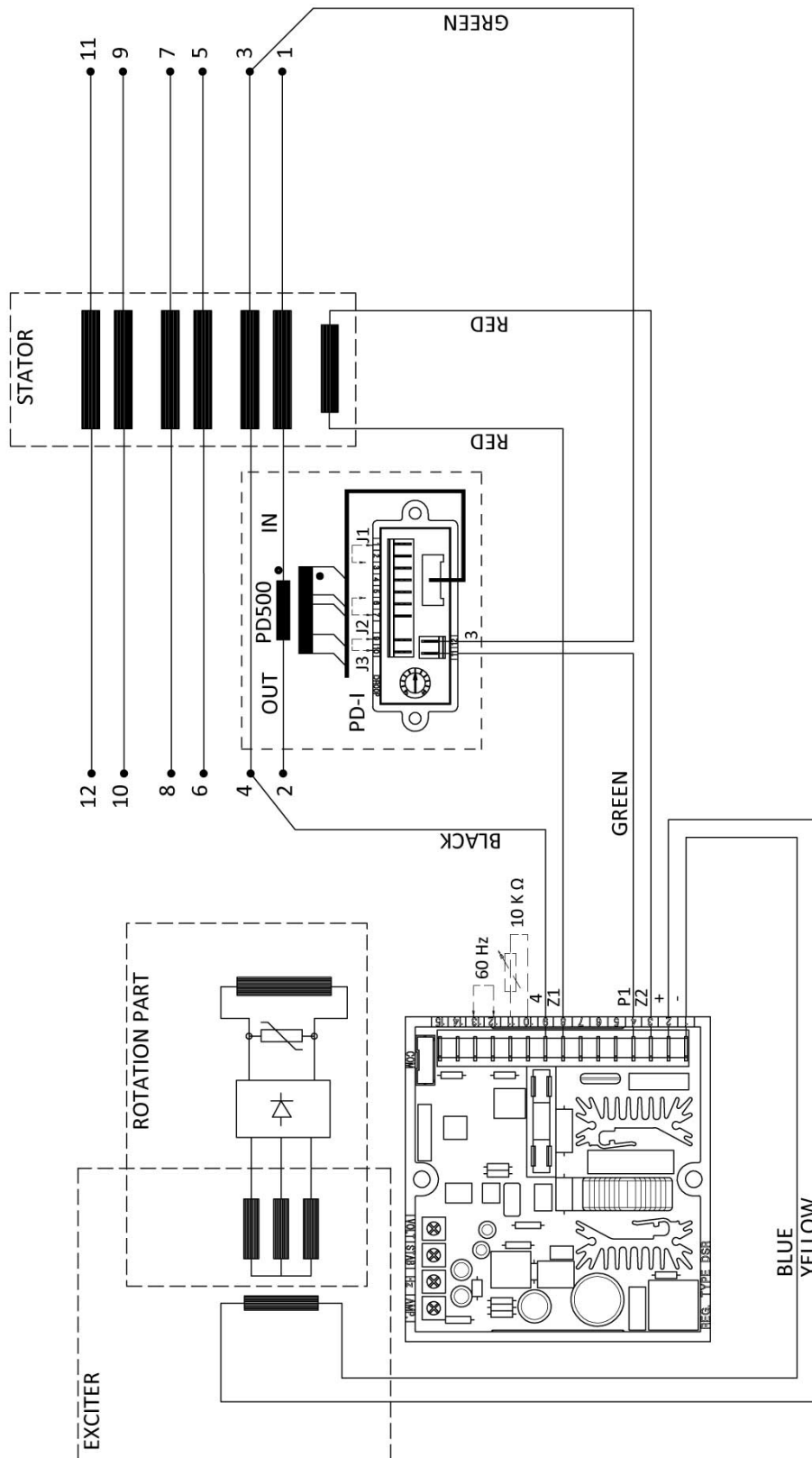

sch_SCC0064-03_001-00

12.2 DER 1 digital regulator electrical diagrams

SCC0161: Alternators with 12 terminals, 150 V - 300 V single-phase sensing.

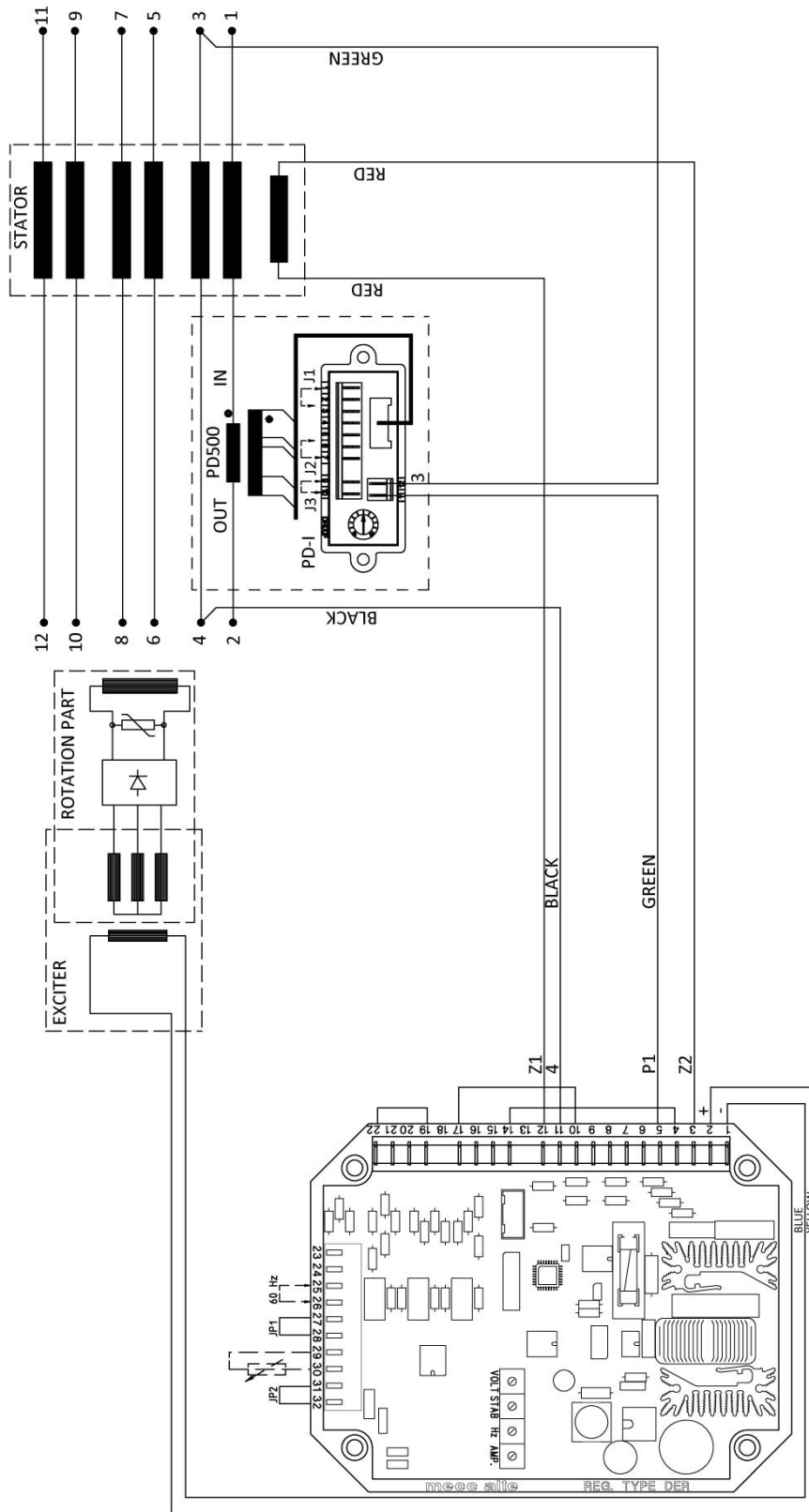

sch_SCC0161-03_001-r00

SCC0160: Alternators with 12 terminals, single-phase reference from 75 V to 150 V.

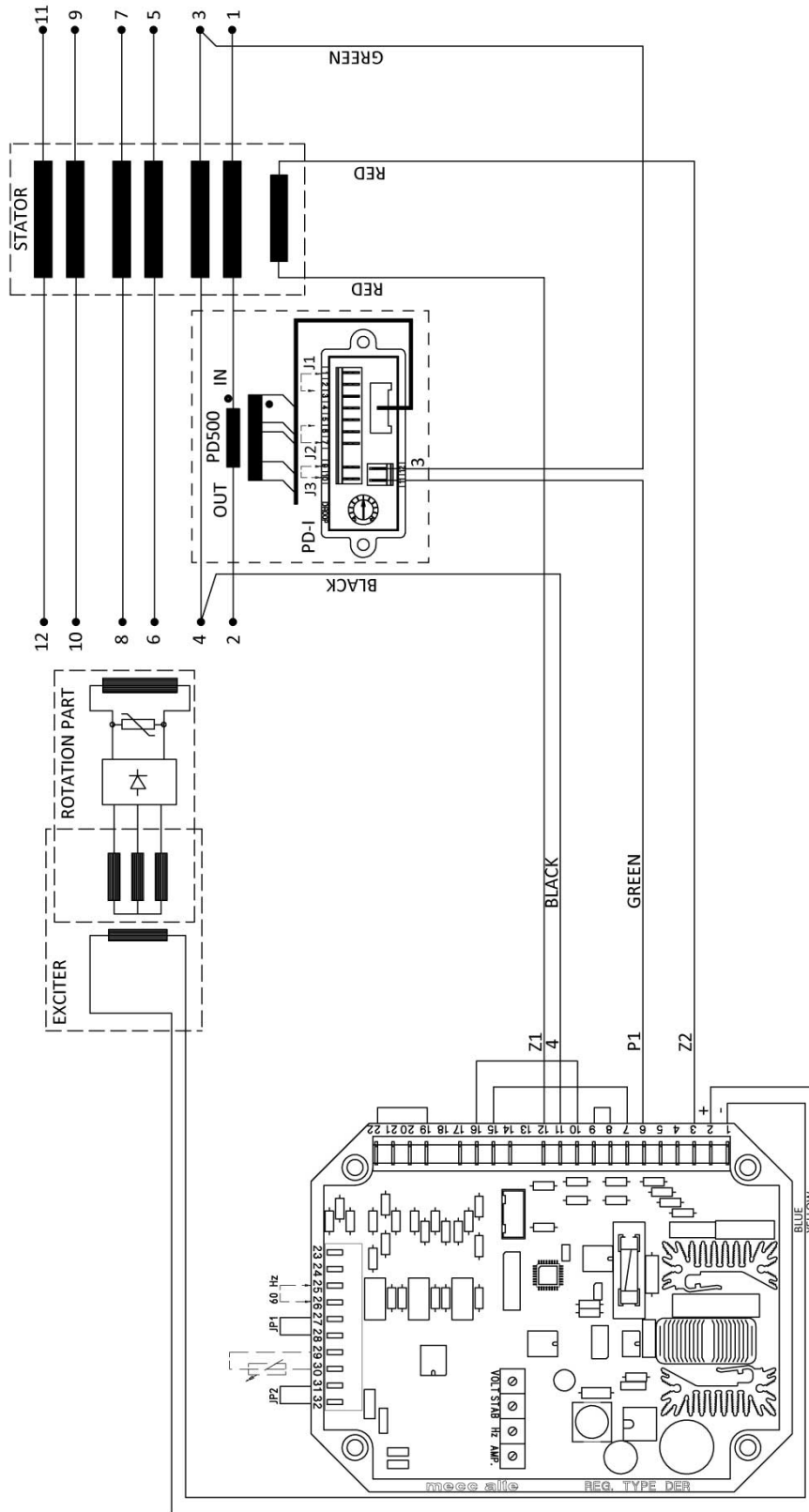

ser_SCC0160-03_001-r00

SCC0159: Alternators with 12 terminals, three-phase reference from 150 V to 300 V.

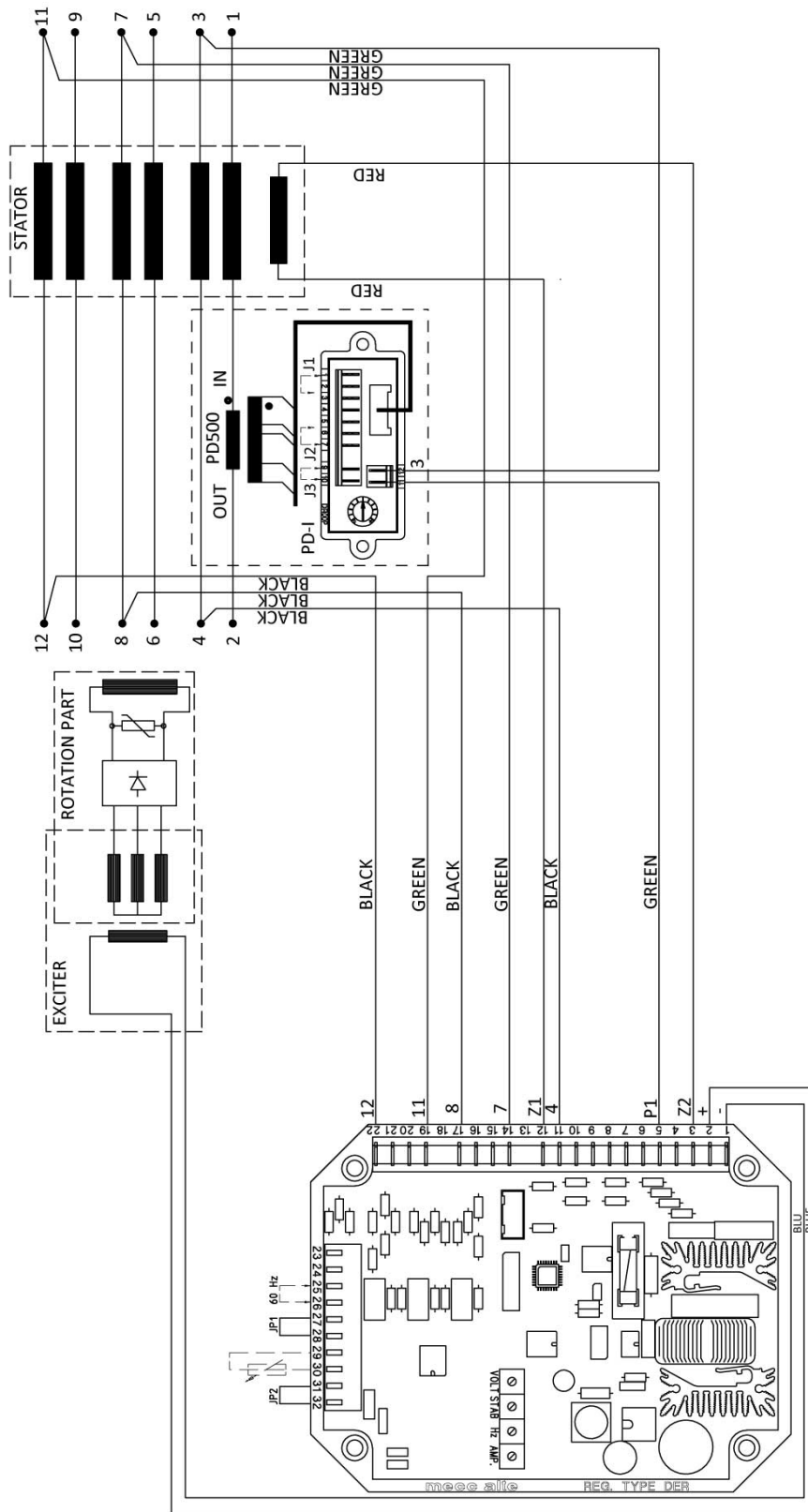

ser_SCC0159-05_001-r00

SCC0158: Alternators with 12 terminals, three-phase reference from 75 V to 150 V.

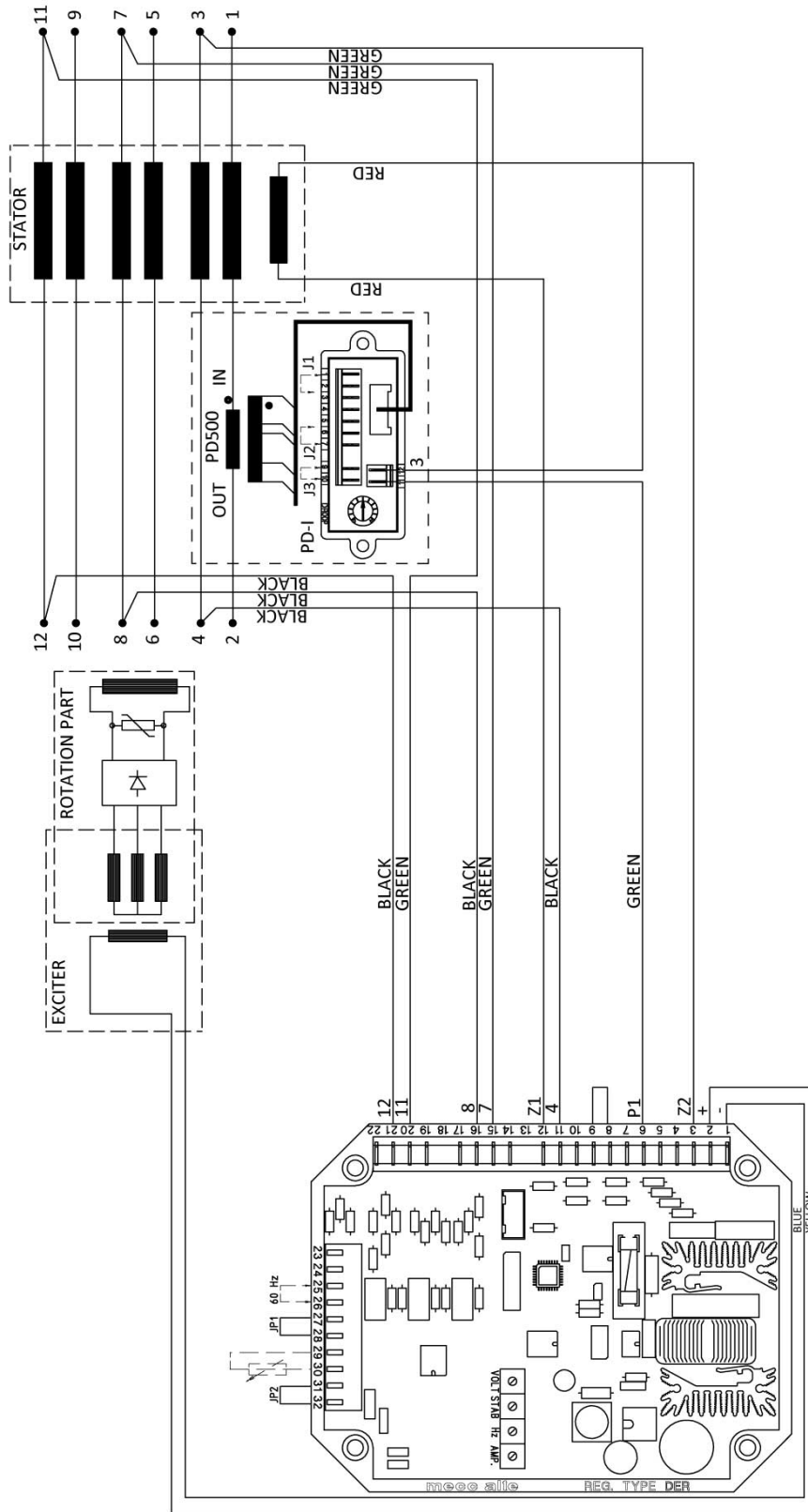

ser_SCC0158-05_001-r00

SCC0202: Alternators with 12 terminals, single-phase reference from 300 V to 600 V.

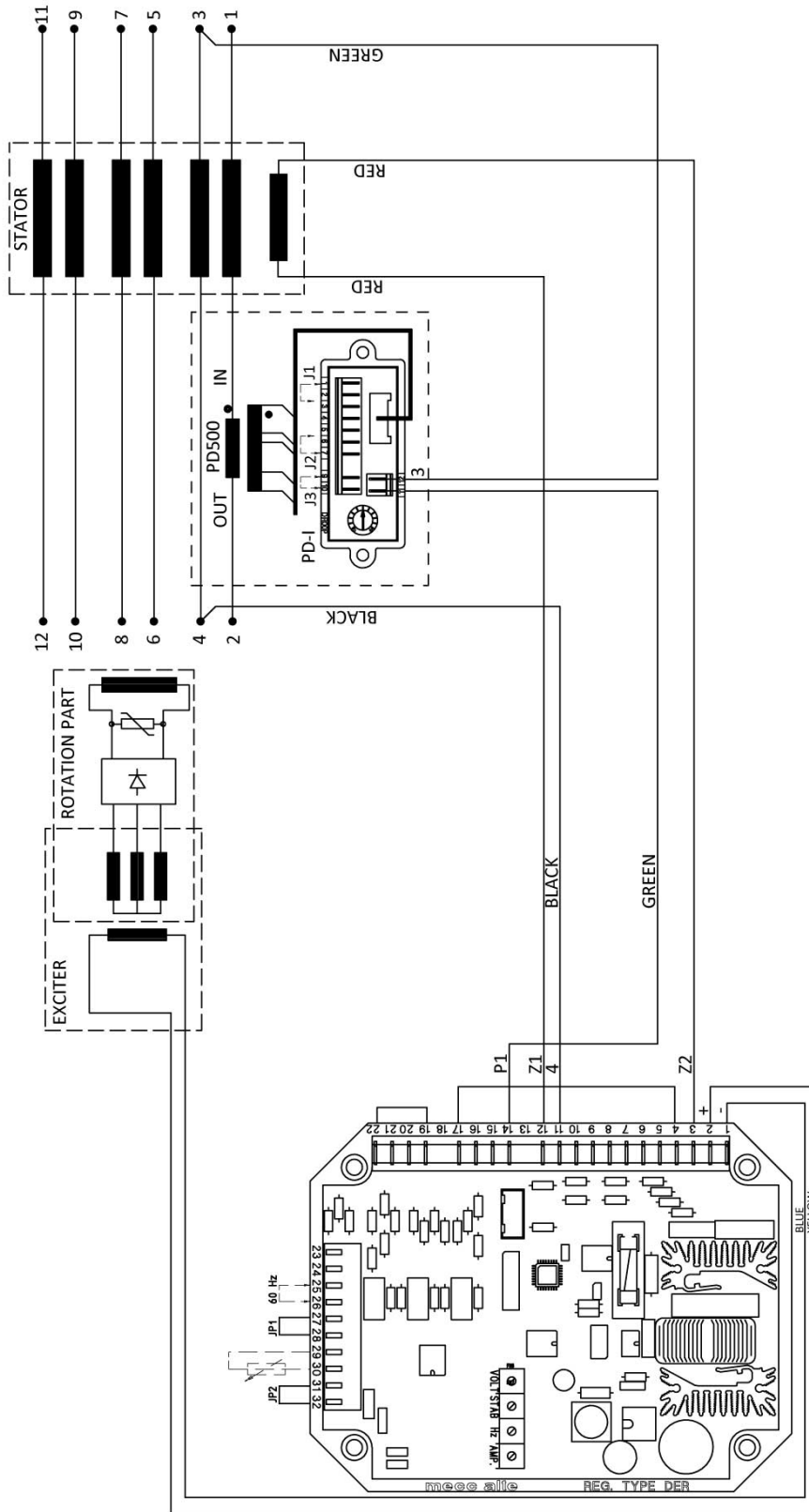

ser_SCC0202_01_001-r00

SCC0203: Alternators with 12 terminals, ZIG-ZAG connection, single-phase reference from 300 V to 600 V.

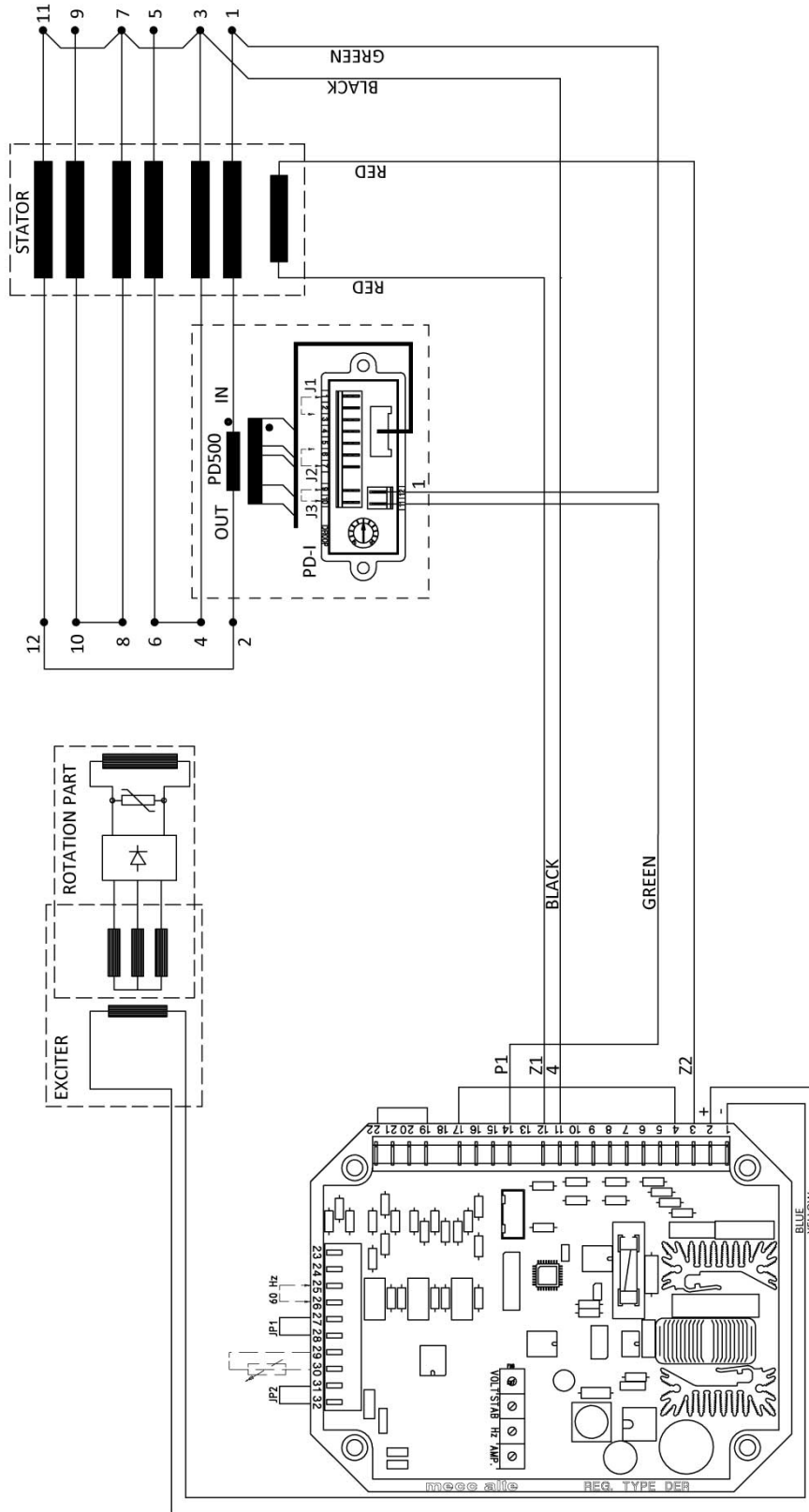

ser_SCC0203-01_001-r00

12.3 Electrical diagrams with UVR6 - SR7 regulators

A2544: Alternators with 6 terminals, with SR7 analog regulator.

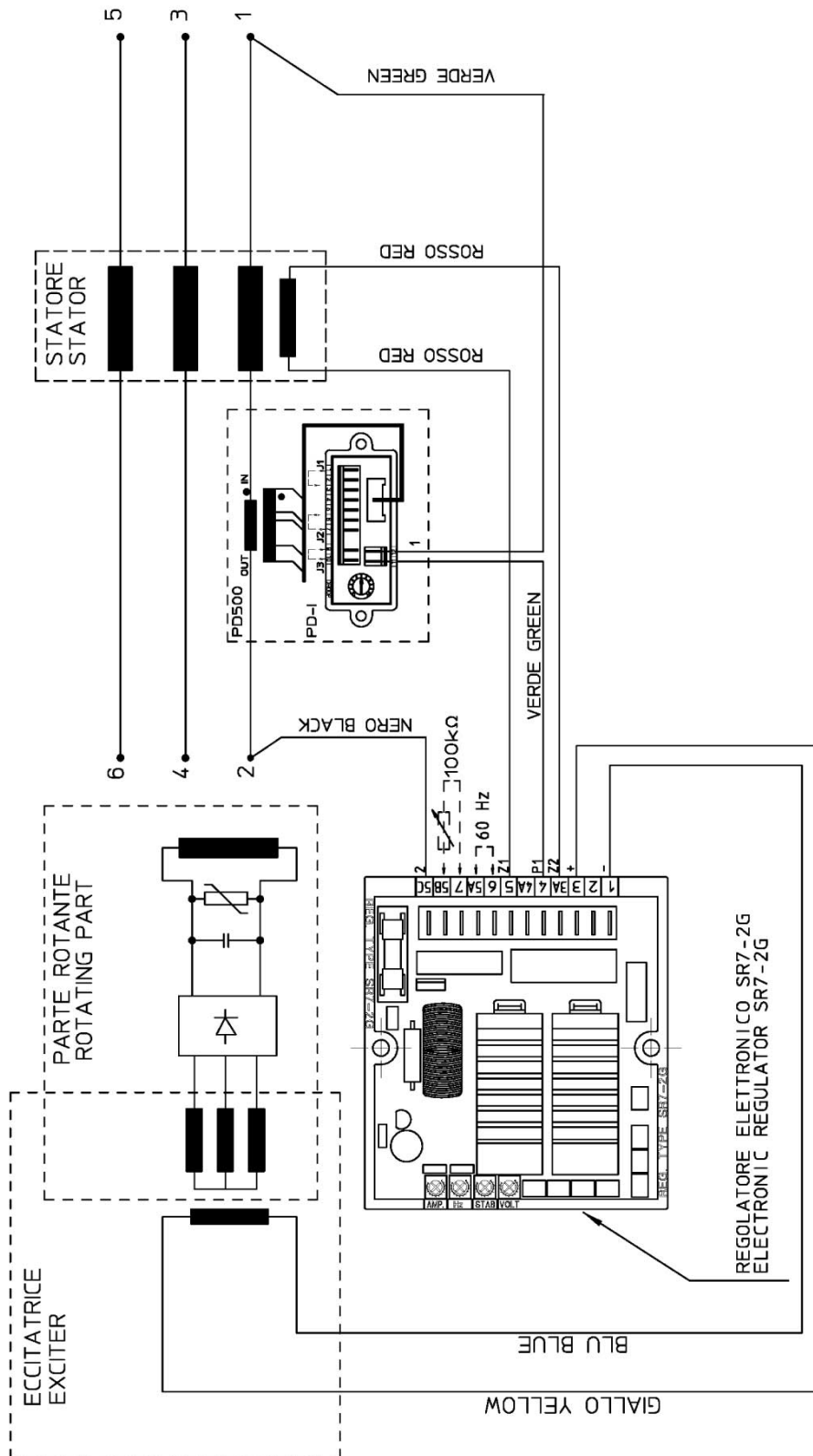

sch_A2544-04_001r00

A2550: Alternators with 6 terminals, with UVR6 analog regulator.

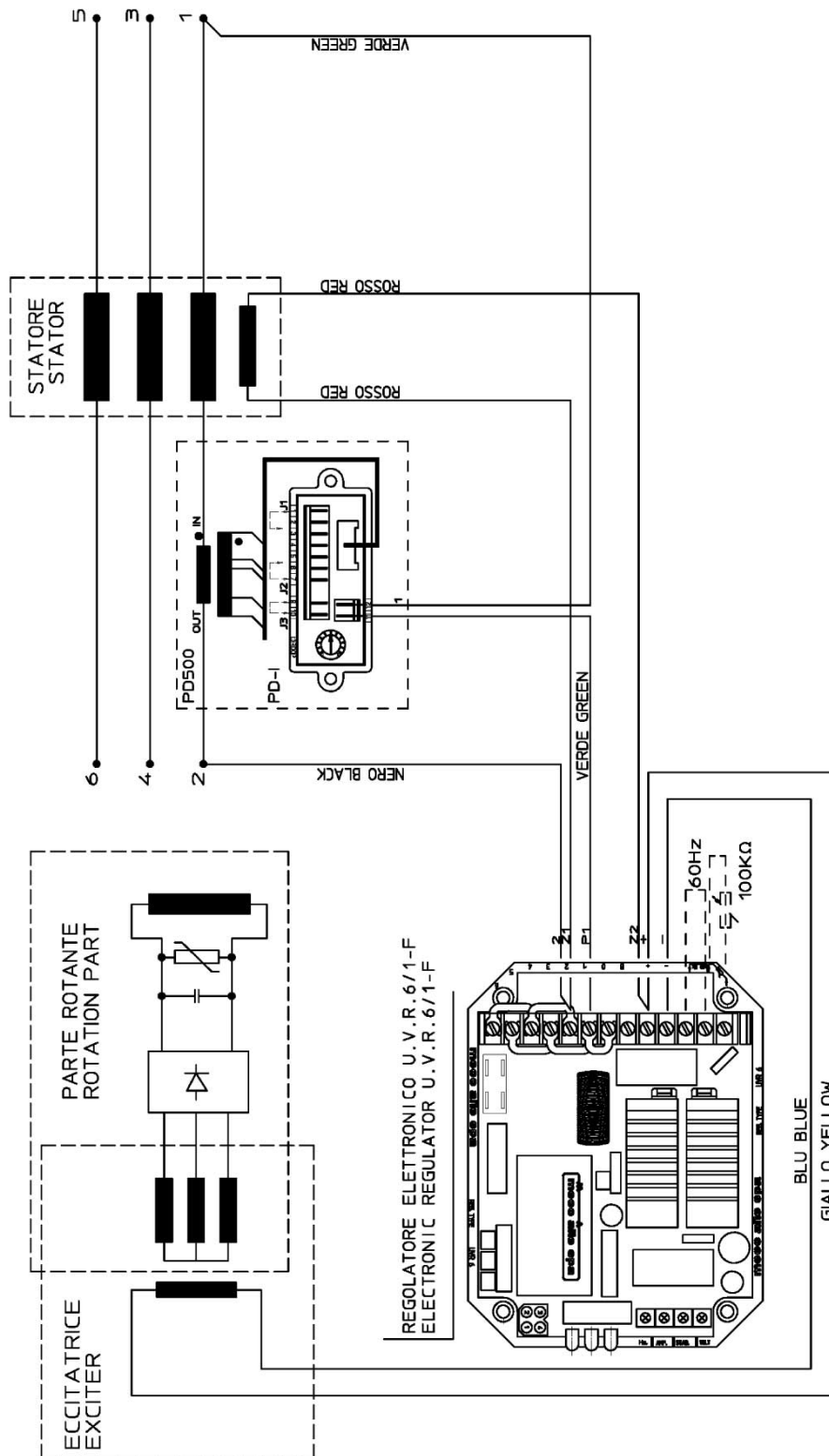

sep_A2550-04_001-00

A2545: Alternators with 12 terminals, with SR7 analog regulator.

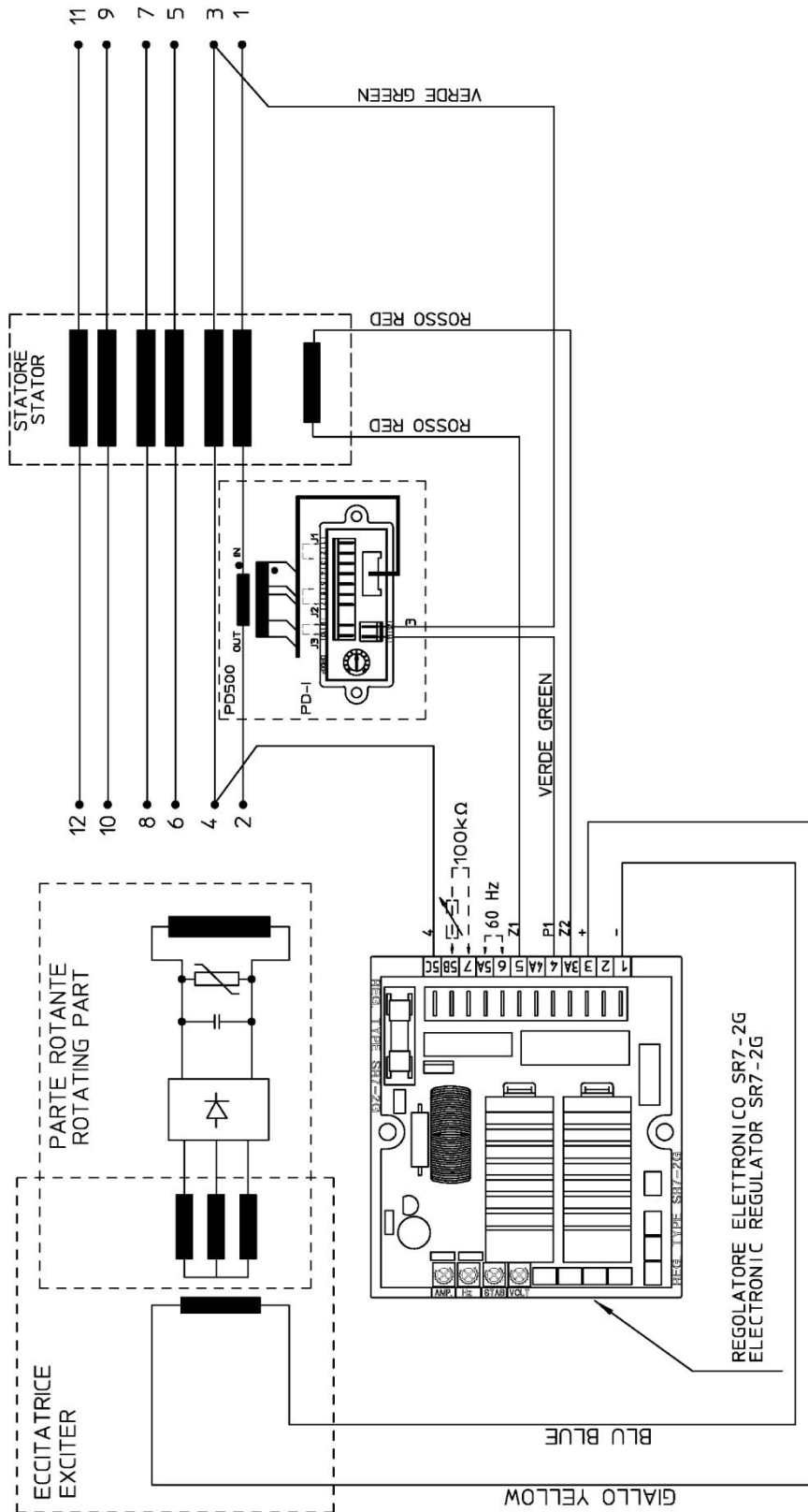

ser_A2545-04_001-00

A2549: Alternators with 12 terminals, with UVR6 analog regulator.

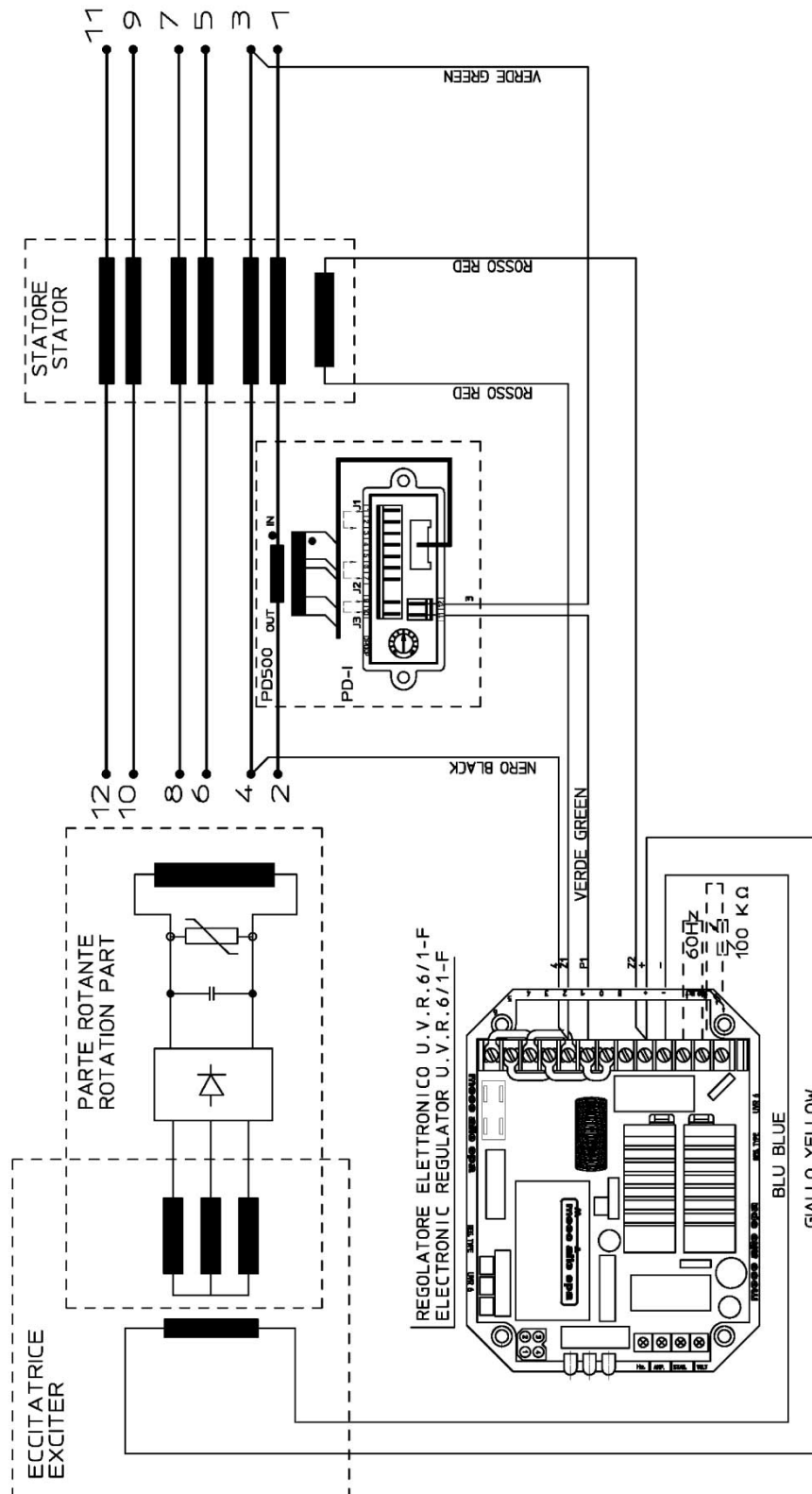

sep_A2549-04_001-00

A2548: Alternators with 6 terminals, three-phase reference with UVR6 analog regulator.

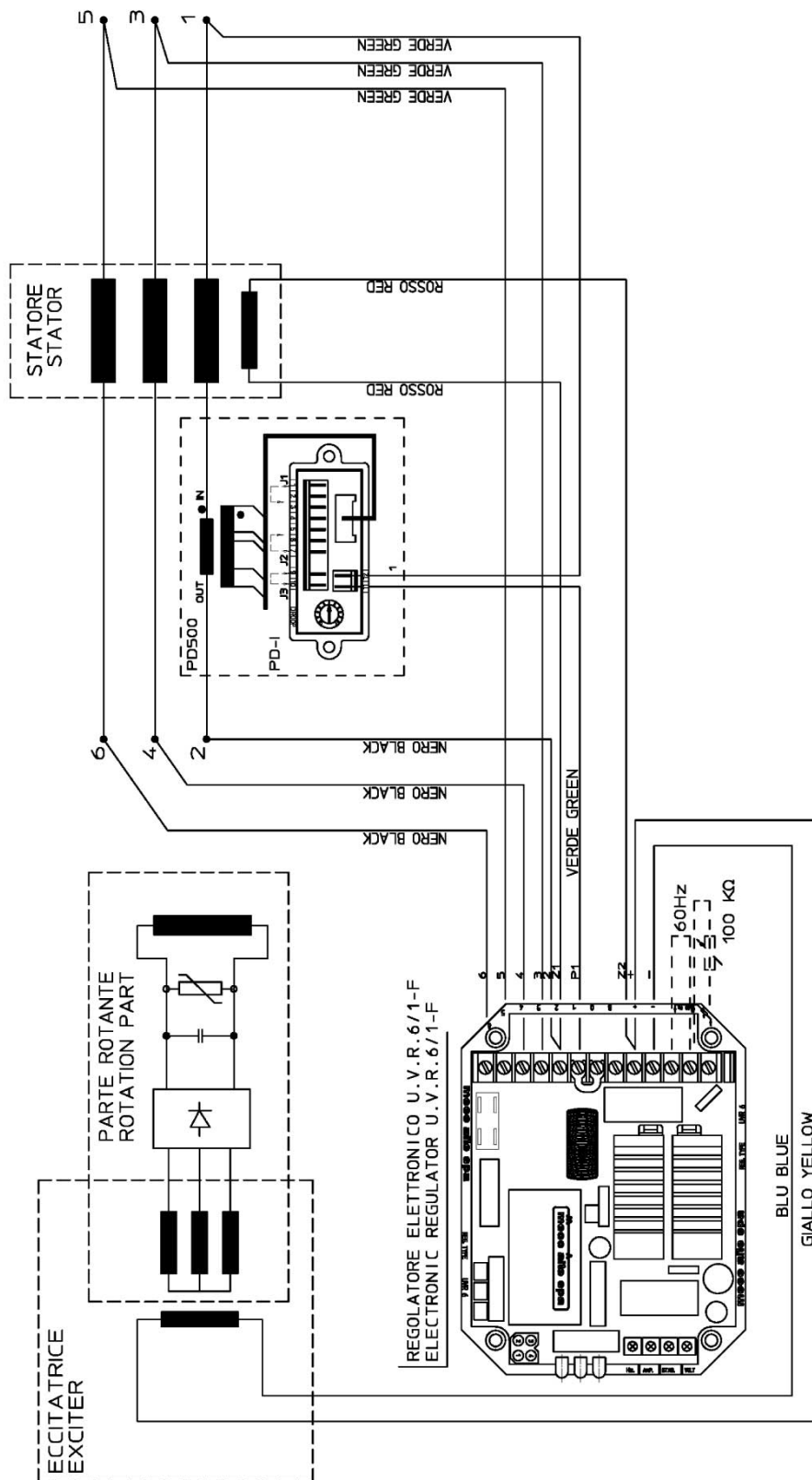

sep_A2548_05_001-00

A2552: Alternators with 12 terminals, three-phase reference with UVR6 analog regulator.

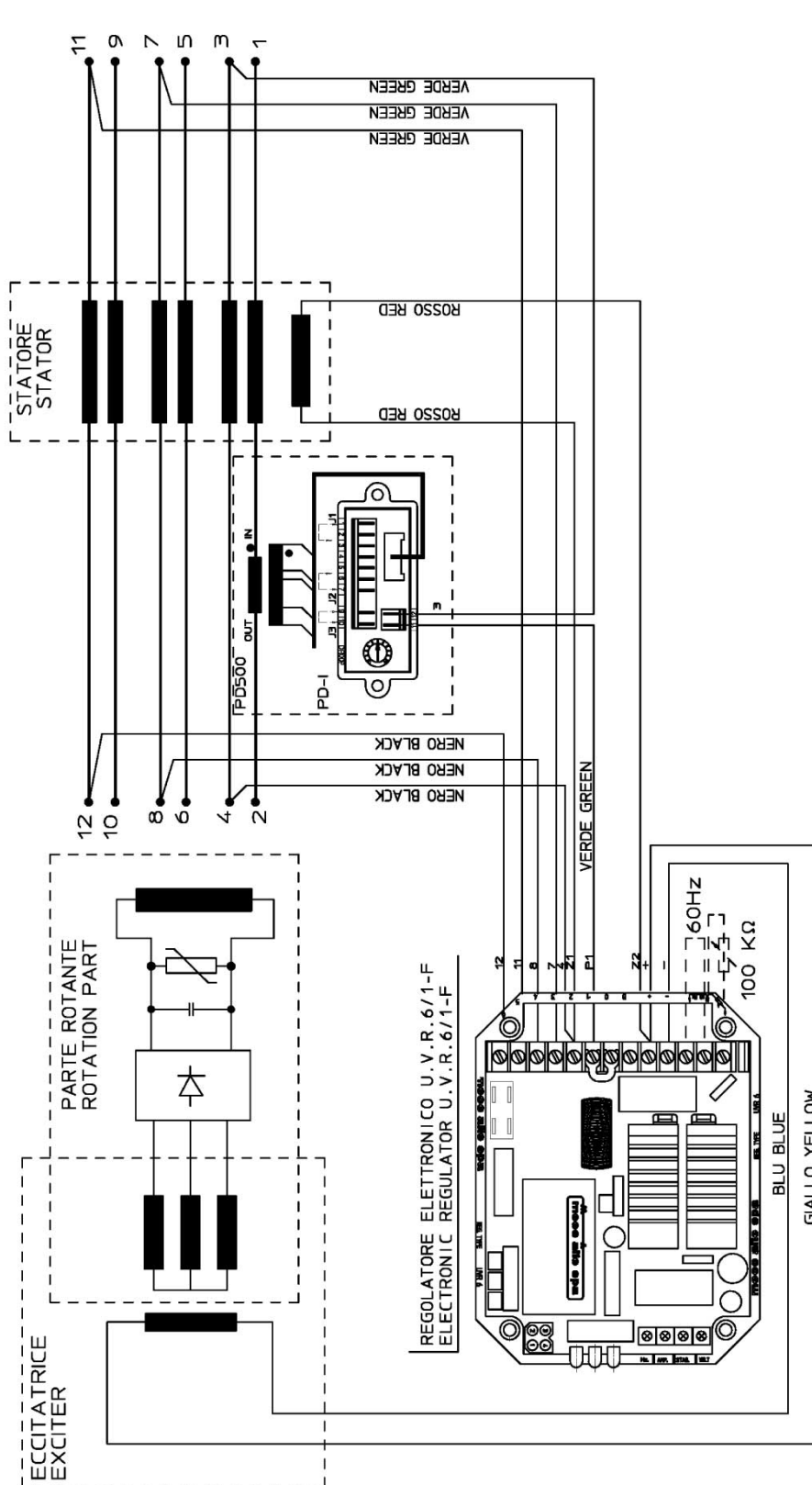

SEP_A2552_04_001-00

13 Replacement parts

13.1 ECP 4C / 4 mounting form MD35

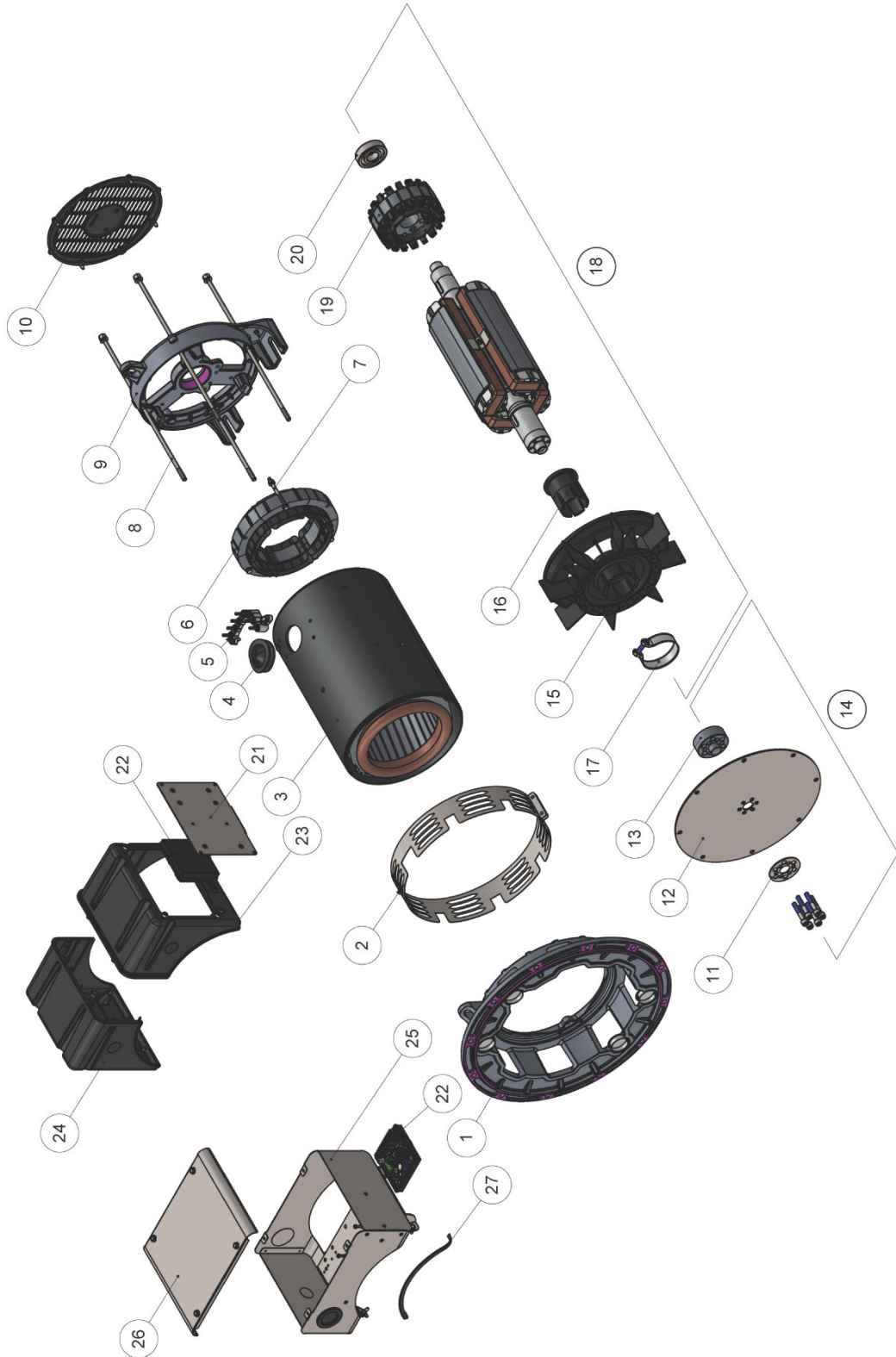

Rev. D00057-01_LECP4C_MD35_001-r00

Spare parts list ECP 4C/4 mounting form MD35

Pos.	Name
1	Front cover (SAE 3, 4, 5)
2	MD35 protection screen
3	Stator with frame
4	Cable grommet diam.50mm
5	7-pin M5 terminal board
6	Exciter stator H 30mm
7	Exciter stator fixing screw
8	Cover tie rod (M, L)
9	Rear bracket
10	Rear cover
11	Disc locking ring
12	DisKS (SAE11 ½, 10, 8, 7 ½, 6 ½)
13	Ring spacer
14	Disks Kit (SAE 11 ½, 10, 8, 7 ½, 6 ½)

Pos.	Name
15	Plastic fan
16	Plastic fan bushing
17	Collar diam. 76x22
18	Main rotor
19	H 30mm rotor exciter
20	6305/2RS rear bearing
21	Regulator plug with screwdriver
22	DSR electronic regulator
23	Side panel - regulator support
24	Side panel - closed
25	Terminal BOX
26	Cover
27	EPDM rubber profile 8.5x5.5mm

13.2 ECP 28C/4 - Mounting form MD35

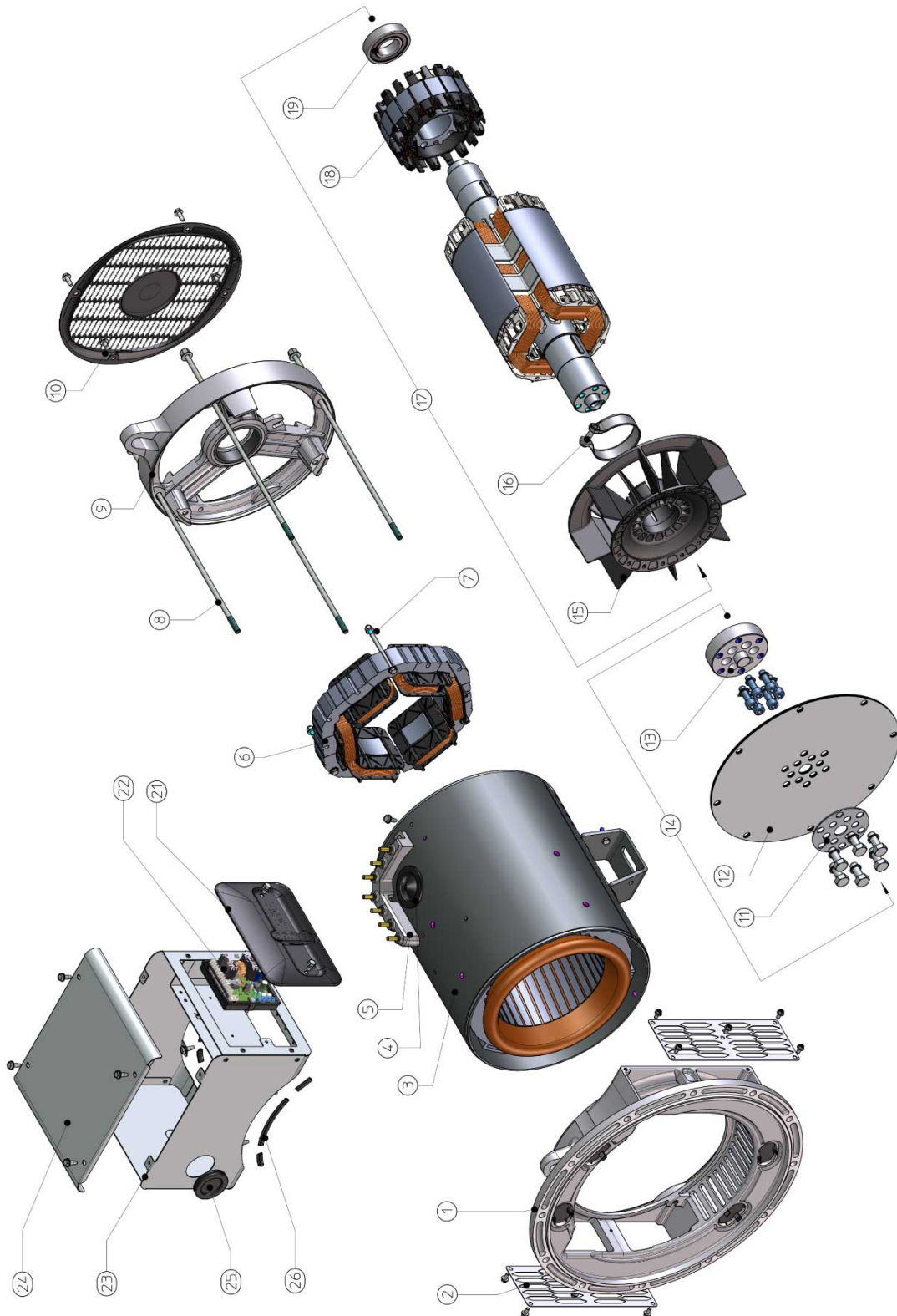

Ten_E0699-01_ECP28C_MD35_001-00

Spare parts list ECP 28C/4 mounting form MD35

Pos.	Name
1	Front cover (SAE 2, 3, 4, 5)
2	MD35 protection screen
3	Stator with frame
4	Cable grommet diam.50mm
5	7-pin M6 terminal board
6	Exciter stator H 35mm
7	Exciter stator fixing screw
8	Cover tie rod (VS, S, M, L, VL)
9	Rear bracket
10	Rear cover
11	Disc locking ring
12	DisKS (SAE11 ½, 10, 8, 7 ½, 6 ½)
13	Ring spacer

Pos.	Name
14	Disks Kit (SAE 11 ½, 10, 8, 7 ½, 6 ½)
15	Plastic fan
16	Collar diam. 76x22
17	Main rotor
18	H 35mm rotor exciter
19	6207/2RS rear bearing
21	Regulator plug with screwdriver
22	DSR electronic regulator
23	Terminal box
24	Cover
25	DG48 cable gland
26	Rubber profile PVC 4,5x5x7,6x1mm

13.3 ECP 28C/4 mounting form B3B14

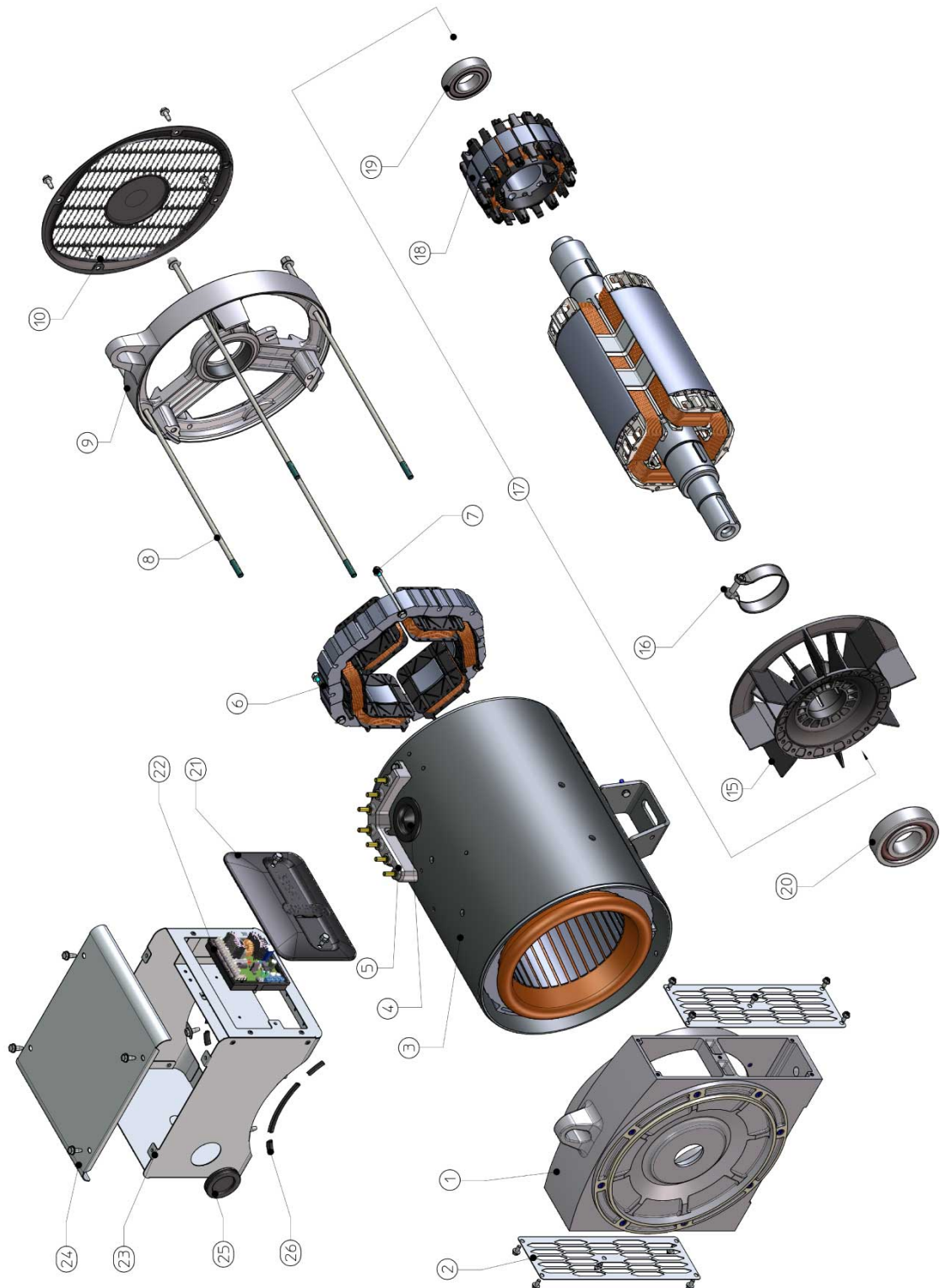

Tel. B0701-02_ECP28C_B3B14_001-00

Spare parts list ECP 28C/4 mounting form B3B14

Pos.	Name
1	B3/B14 front bracket
2	B3/B14 protection screen
3	Frame with stator
4	Cable grommet diam. 50mm
5	7-pin M6 terminal board
6	H. 35mm stator exciter
7	Exciter stator fixing screw
8	Cover tie rod (VS, S, M, L, VL)
9	Rear bracket
10	Rear cover
15	Plastic fan

Pos.	Name
16	Collar diam. 76x22
17	Main rotor
18	H. 35mm rotor exciter
19	6207/2RS rear bearing
20	6309/2RS front bearing
21	Regulator plug with screwdriver
22	DSR electronic regulator
23	Terminal box
24	Cover
25	Cable grommet DG36
26	Rubber profile PVC 4,5x5x7,6x1mm

13.4 ECP 30C/4 - Mounting form MD35



Rev_D00160_00_ECP30C_MD35_001-000

ECP 30C/4 - Mounting form MD35 Spare parts

Pos.	Name
1	Front cover (SAE 3, 4, 5)
2	MD35 protection screen
3	Stator with frame
4	Cable grommet diam.50mm
5	7-pin M6 terminal board
6	Exciter stator H 35mm
7	Exciter stator fixing screw
8	Cover tie rod (M, L)
9	Rear bracket
10	Rear cover
11	Disc locking ring
12	DisKS (SAE11 ½, 10, 8, 7 ½, 6 ½)
13	Ring spacer
14	Disks Kit (SAE 11 ½, 10, 8, 7 ½, 6 ½)

Pos.	Name
15	Plastic fan
16	Collar diam. 76x22
17	Main rotor
18	H 35mm rotor exciter
19	6207/2RS rear bearing
20	Regulator support panel
21	DSR electronic regulator
22	Regulator side terminal box
23	Closed side terminal box
24	Terminal box (Metal)
25	Cover
26	Rubber profile PVC 8,5x5,5mm
27	Cable grommet DG36
28	Reulator plug with screwdriver

13.5 ECP 32C / 4 mounting form MD35

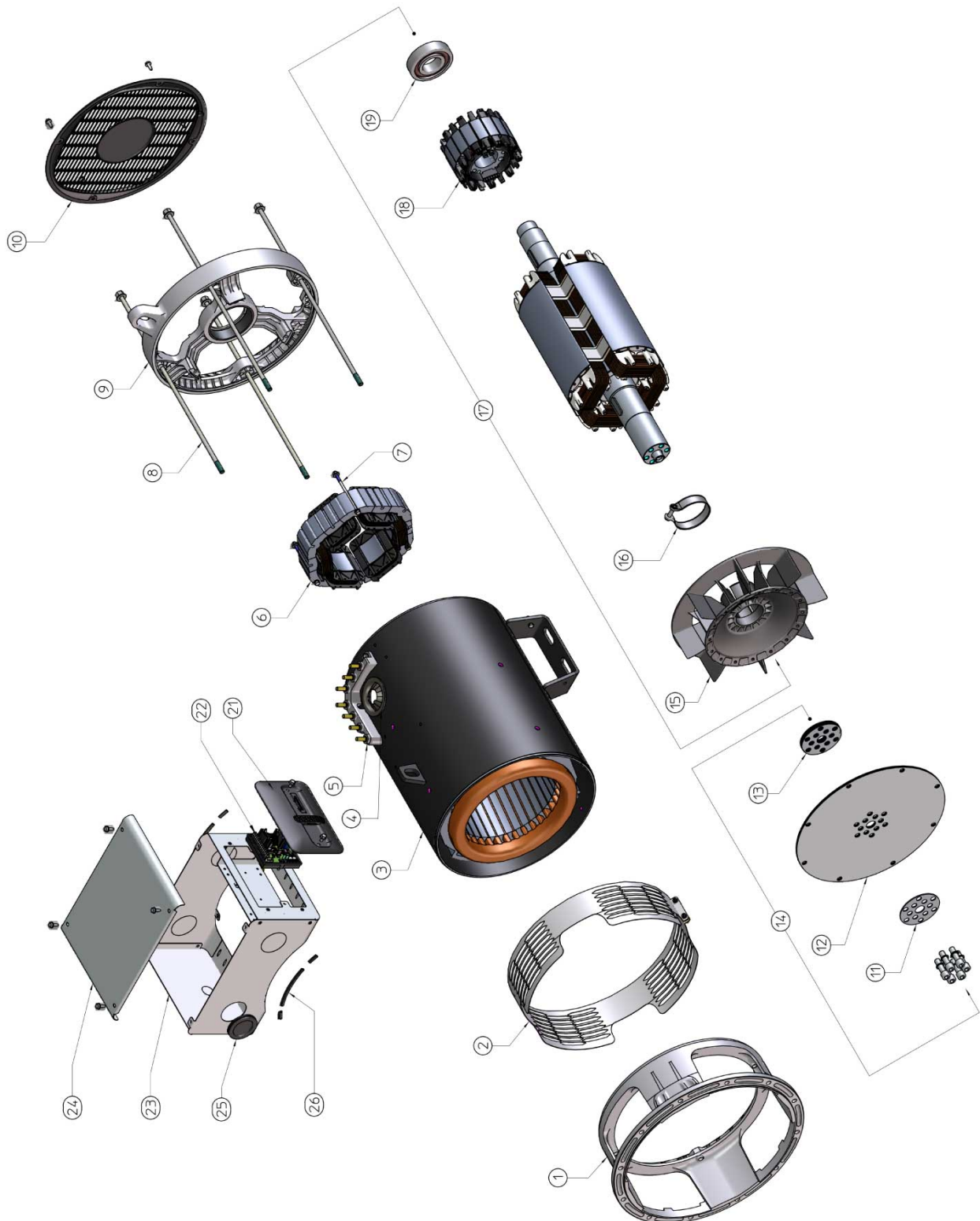

Ten_B0774-01_ECP32C_MD35_001-00

Spare parts list ECP 32C/4 mounting form MD35

Pos.	Name
1	Front bracket MD35 SAE 1, 2, 3, 4, 5
2	Protection screen MD35, SAE1/2/4/5 , 3
3	Frame with stator
4	Cable grommet diam. 70mm
5	7-pin M8 terminal board
6	Exciter stator H 45/55 mm
7	Screw fixing st. exciter H45 / 55 mm
8	Cover tie rod S,M,L
9	Rear bracket
10	Rear cover
11	Disc locking ring
12	Disks SAE 11 ½, 10, 8, 7 ½, 6 ½
13	Spacer

Pos.	Name
14	Disks kit SAE 11 ½, 10, 8, 7, 6 ½
15	Plastic fan
16	Collar diam. 82x22
17	Main rotor
18	Exciter rotor H. 45/55 mm
19	6309/2RS rear bearing
21	Reulator plug with screwdriver
22	DSR electronic regulator
23	Terminal box
24	Cover
25	Cable gland DG48
26	Rubber profile PVC 4.5x5x7, 6x1mm

13.6 ECP 32C / 4 mounting form B3B14

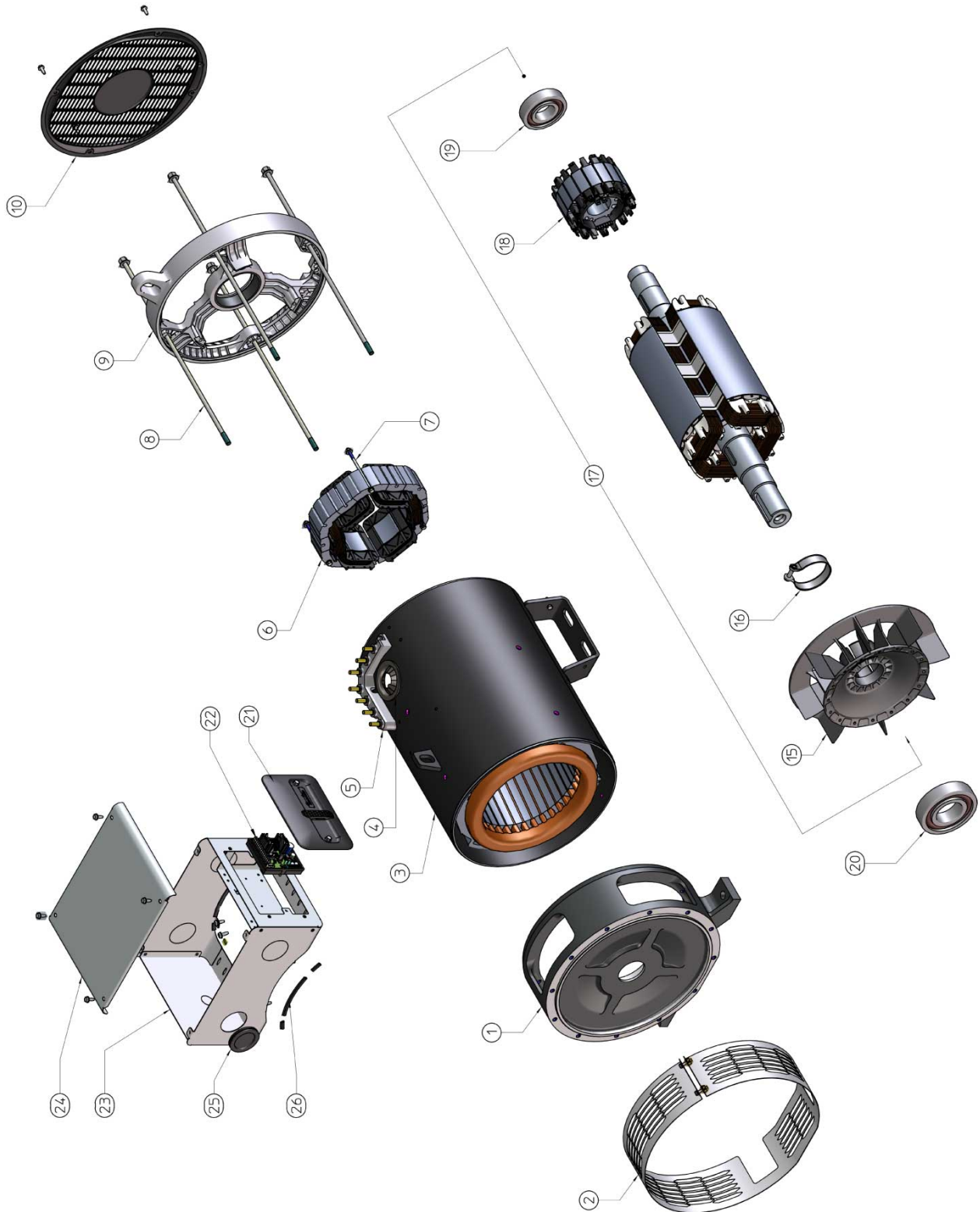

Ten_B0772-02_ECP32C_B3B14_001-000

Spare parts list ECP 32C/4 type B3B14

Pos.	Name
1	B3/B14 front bracket
2	B3/B14 protection screen
3	Frame with stator
4	Cable grommet diam. 70mm
5	7-pin M8 terminal board
6	Exciter stator H. 45mm or 55mm
7	Fixing screw st. exciter H 45mm or 55mm
8	Cover tie rod S, M, L
9	Rear bracket
10	Rear cover
16	Collar diam. 82x22

Pos.	Name
17	Main rotor
18	Exciter rotor H.45mm or 55mm
19	6309/2RS rear bearing
20	6312/2RS front bearing
21	Regulator plug with scredriver
22	DSR electronic regulator
23	Terminal box
24	Cover
25	Cable gland DG48
26	Rubber profile PVC 4,5x5x7,6x1mm

13.7 ECP 34C / 4 mounting form MD35

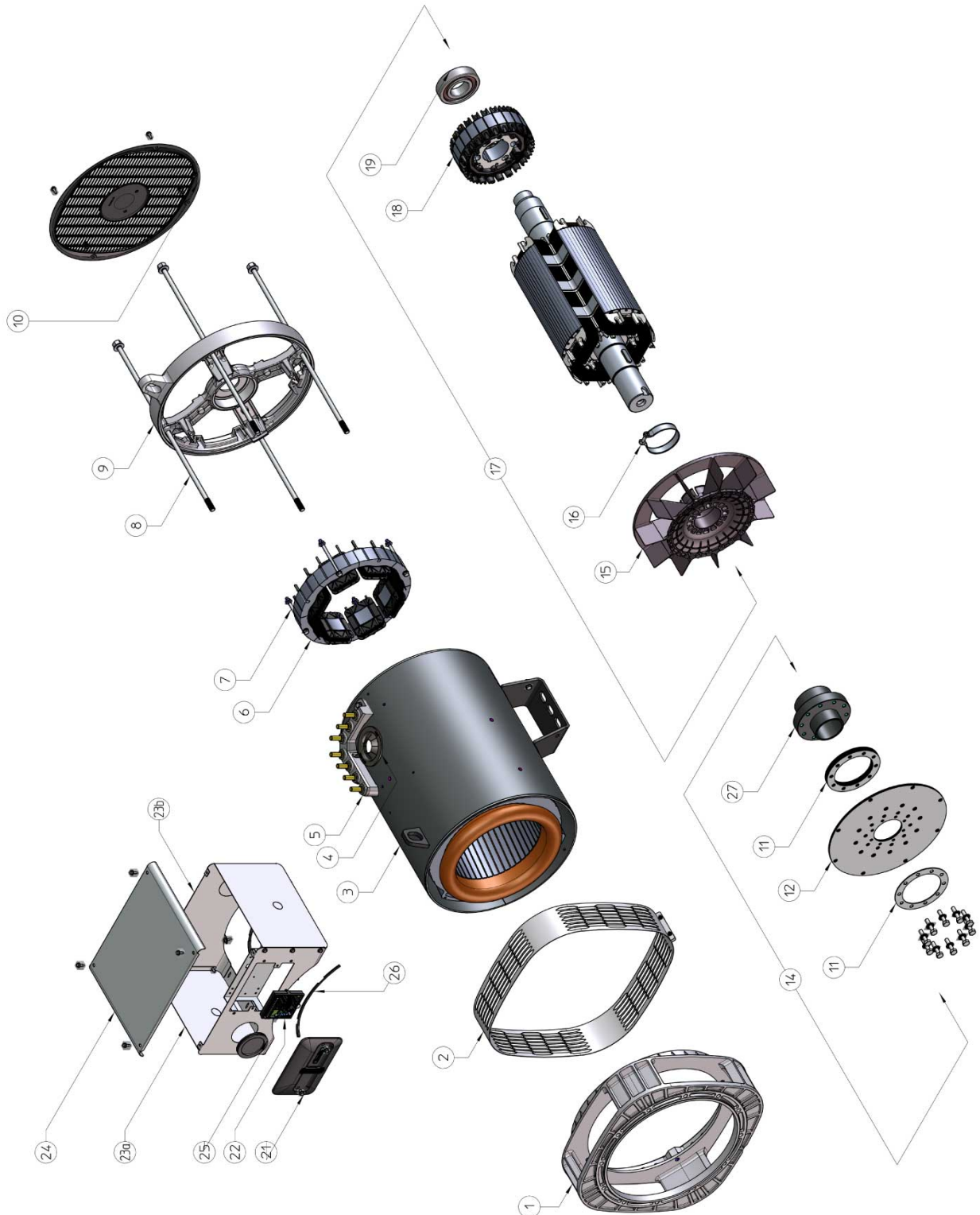

Tav. B1708-00_ECP34C_MD35_001-00

Spare parts list ECP 34C/4 mounting form MD35

Pos.	Name
1	Rear Grid
2	Terminal box cover
3	Terminal board
4	Rear bracket
5	Frame with stator
6	MD35 SAE1 front bracket
7	Exciter stator fixing screw
8	Cover tie rod S,M,L
9	Rear bracket
10	Rear cover
11	Disc locking ring
12	Disks SAE 14, 11 ½, 10
14	Disks Kit SAE 14, 11 ½, 10
15	Plastic fan

Pos.	Name
16	Collar diam. 76x22
17	Main rotor
18	45mm exciter rotor
19	6311/2RS rear bearing
21	Reulator plug with screwdriver
22	DSR electronic regulator
23a	Side panel - regulator support
23b	Side panel - closed
24	Cover
25	Cable grommet DG69
26	Rubber profile PVC 4.5x5x7, 6x1mm
27	Universal hub

13.8 ECP 34C/4 mounting form B3B14

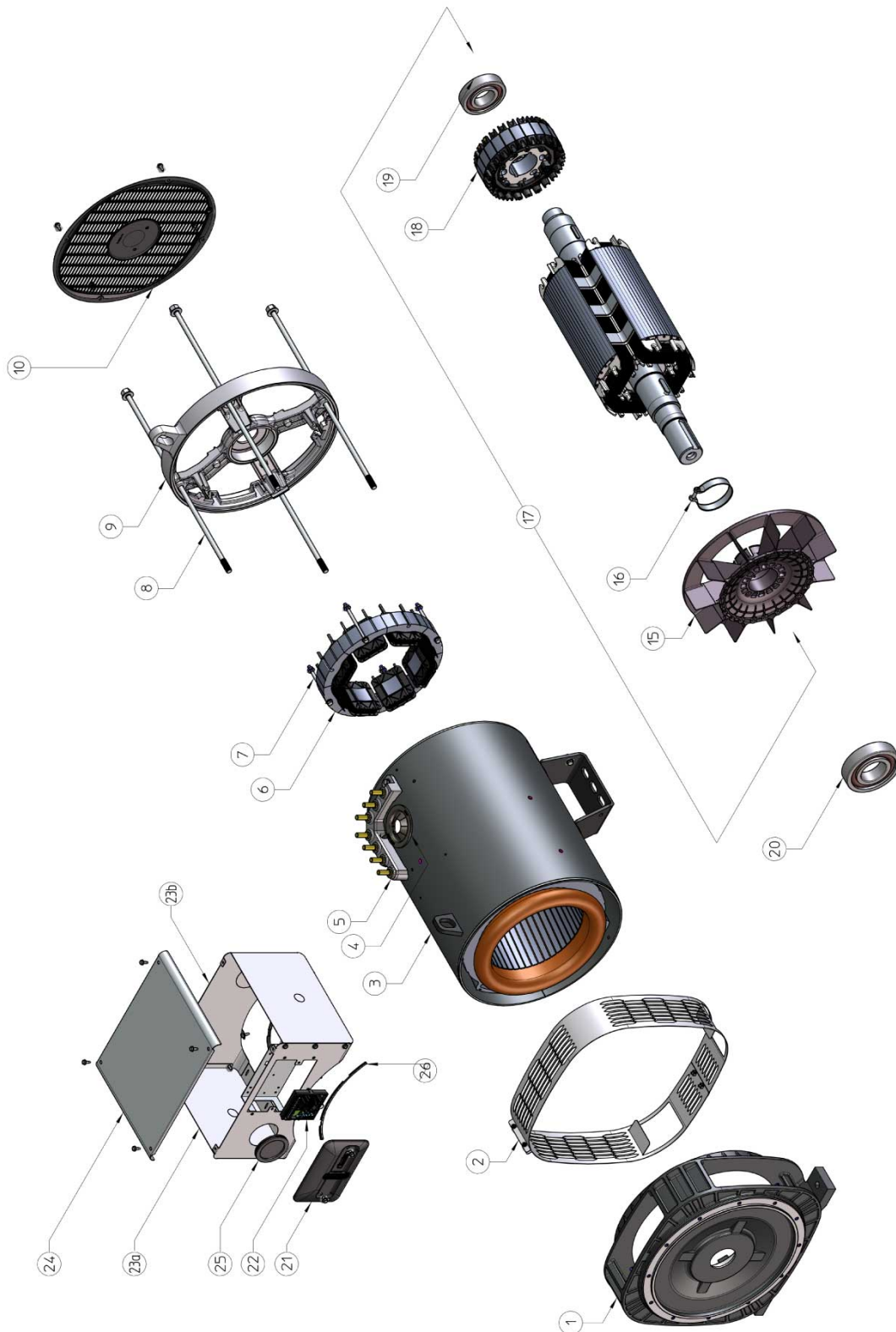

Tel. 01709.00_ECP34C_B3B14_001-000

Spare parts list ECP 34C/4 mounting form B3B14

Pos.	Name
1	B3B14 front bracket
2	B3B14 protection screen
3	Frame with stator
4	Cable grommet diam. 90mm
5	7-pin M12 terminal board
6	45mm exciter stator
7	Exciter stator fixing screw
8	Cover tie rod S, M, L
9	Rear bracket
10	Rear cover
15	Plastic fan
16	Collar diam. 76x22
17	Main rotor
18	45mm exciter rotor

Pos.	Name
19	6311/2RS rear bearing
20	6314/2RS front bearing
21	Regulator plug with scredriver
22	DSR electronic regulator
23a	Side panel - regulator support
23b	Side panel - closed
24	Cover
25	Cable grommet DG69
26	Rubber profile PVC 4,5x5x7,6x1mm

14 Dismantlement and disposal

To dispose of the alternator or its components you will have to recycle it, keeping in mind the nature of its various components (for instance: metals, plastic parts, rubber, oil and so on).

You will have to designate specialized companies for this purpose and , however, observe the waste management applicable laws.



Most of the materials used in the alternators can be recycled by specialized waste management companies. The instructions contained in this chapter are recommendations to follow for environmentally sound disposal; the user has the responsibility of observing local regulations.



For indicative percentages of the materials used in Mecc Alte alternators see paragraph 2.3.10.

Mecc Alte SpA (HQ)

Via Roma
20 – 36051 Creazzo
Vicenza – ITALY
T: +39 0444 396111
F: +39 0444 396166
E: info@meccalte.it
aftersales@meccalte.it

Mecc Alte Portable

Via A. Volta
1 – 37038 Soave
Verona – ITALY
T: +39 045 6173411
F: +39 045 6101880
E: info@meccalte.it
aftersales@meccalte.it

Mecc Alte Power Products srl

Via Melaro
2 – 36075 Montecchio
Maggiore (VI) – ITALY
T: +39 0444 1831295
F: +39 0444 1831306
E: info@meccalte.it
aftersales@meccalte.it

Zanardi Alternators

Via Dei Laghi
48/B – 36077 Altavilla
Vicenza – ITALY
T: +39 0444 370799
F: +39 0444 370330
E: info@zanardialternatori.it

United Kingdom

Mecc Alte U.K. LTD
6 Lands' End Way
Oakham
Rutland LE15 6RF
T: +44 (0) 1572 771160
F: +44 (0) 1572 771161
E: info@meccalte.co.uk
aftersales@meccalte.co.uk

Spain

Mecc Alte España S.A.
C/ Rio Taibilla, 2
Polig. Ind. Los Valeros
03178 Benijofar (Alicante)
T: +34 (0) 96 6702152
F: +34 (0) 96 6700103
E: info@meccalte.es
aftersales@meccalte.es

China

Mecc Alte Alternator Haimen LTD
755 Nanhai East Rd
Jiangsu HEDZ 226100 PRC
T: +86 (0) 513 82325758
F: +86 (0) 513 82325768
E: info@meccalte.cn
aftersales@meccalte.cn

India

Mecc Alte India PVT LTD
Plot NO: 1, Sanaswadi
Talegaon
Dhamdhare Road Taluka:
Shirur, District:
Pune - 412208
Maharashtra, India
T: +91 2137 619600
F: +91 2137 619699
E: info@meccalte.in
aftersales@meccalte.in

U.S.A. and Canada

Mecc Alte Inc.
1229 Adams Drive
McHenry, IL, 60051
T: +1 815 344 0530
F: +1 815 344 0535
E: info@meccalte.us
aftersales@meccalte.us

Germany

Mecc Alte Generatoren GmbH
Ensener Weg 21
D-51149 Köln
T: +49 (0) 2203 503810
F: +49 (0) 2203 503796
E: info@meccalte.de
aftersales@meccalte.de

Australia

Mecc Alte Alternators PTY LTD
10 Duncan Road, PO Box 1046
Dry Creek, 5094, South
Australia
T: +61 (0) 8 8349 8422
F: +61 (0) 8 8349 8455
E: info@meccalte.com.au
aftersales@meccalte.com.au

France

Mecc Alte International S.A.
Z.E.La Gagnerie
16330 ST.Amant de Boixe
T: +33 (0) 545 397562
F: +33 (0) 545 398820
E: info@meccalte.fr
aftersales@meccalte.fr

Far East

Mecc Alte (F.E.) PTE LTD
19 Kian Teck Drive
Singapore 628836
T: +65 62 657122
F: +65 62 653991
E: info@meccalte.com.sg
aftersales@meccalte.com.sg



www.meccalte.com