



Totally Focused. Totally Independent.

Technical Specification

ECP28 4 C



The world's largest
independent producer of
alternators 1 – 5,000kVA

All electrical / mechanical data are to be considered as a reference and they can be modified without any notice.

This document is a propriety of Mecc Alte S.p.A.. All rights reserved.

Standards

Alternators are designed and produced within an ISO 9001 environment. The entire series is manufactured according to, and complies with, the most common specifications such as CEI 2-3, IEC 34-1, EN 60034-1, VDE 0530, BS 4999-5000, NF 51.111, NEMA MG 1-2011, ISO 8528-3. They also comply with other specific standards such as UL1446, UL 1004/4 and /B and CAN/CSA-C22.2 No14-95-No100-95.

Windings and Performances

All windings are 2/3rds pitch to eliminate triplen harmonics within the voltage waveform and to avoid excessive neutral currents in certain parallel operating conditions. A fully interconnected aluminium or copper damper cage is supplied on the rotor of all models (excluding the ECP3 series).

- ▶ 12 wire reconnectable:
50Hz – 380V to 440V and 220/110V to 240/120V (de-rates may apply at certain voltages)
60Hz – 380V to 480V and 220/110V to 240/120V (de-rates may apply at certain voltages)
- ▶ 6 wire reconnectable:
50Hz – 380V to 440V and 220V to 240V (de-rates may apply at certain voltages)
60Hz – 380V to 480V and 220V to 240V (de-rates may apply at certain voltages)

Winding Configurations	Standard		Special (dedicated)			
	12 wire Reconnectable	6 wire Reconnectable	380V and 600V 60Hz	690V 50/60Hz	220-240V 1ph 50Hz	220-240V 1ph 60Hz
ECP3 to ECO38	Std	Option	Option	Option	Option	Option
ECO40 to ECO46	Std	Option	Option	Option	Option (to ECO40)	
ECO47	Std 4 wires		Option	Option		
Insulation materials	Class H	Class H	Class H	Class H	Class H	Class H
High efficiency	Std	Std	Std	Std	Std	Std
High motor starting	>300%	>300%	>300%	>300%	>300%	>300%
THD (Total Harmonic Distortion)	Typically <3.5% full load L-L	Typically <3.0% full load L-L	Typically <3.5% full load L-L	Typically <3.5% full load L-L	Typically <4.5% full load L-N	Typically <4.5% full load L-N
Interference suppression	VDE 0875 G/N/K, EN61000-6-3, EN61000-6-2, others available on request					

Winding Protection

There are various degrees of protection for the windings following the standard impregnation process, as can be seen here. The TOTAL+ butadienic black flexible coating is recommended for arduous applications.

Winding Protection:	STANDARD	STANDARD+	GREY	GREY+	TOTAL+
ECP3	Std	Option	Option	Option	Option
ECP28 and ECP32	-	Std	Option	Option	Option
NPE, ECP34 to ECO47	-	-	Std	Option	Option

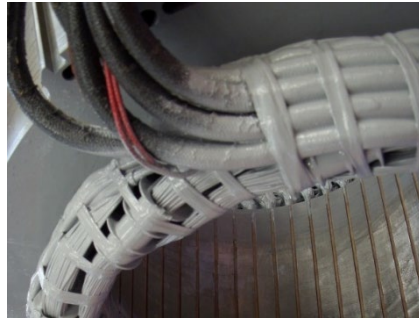

Grey treatment (marinization) on the left, TOTAL+ treatment shown on the right. The EG43 grey varnish, is an high temperature insulating enamel that forms a tough and flexible film, with excellent moisture and chemical protection. It is water and oil proof, and also protects windings from abrasion. It is applied spraying an over coating layer over the impregnated winding, or dipping the stator in a varnish barrel for superior treatments.

The TOTAL+ is a Mecc Alte protection system. It is the ultimate winding treatment that offers truly superior performances when the environment is really harsh, or the application very demanding. The TOTAL+ is also extremely resistant to the particle abrasion as it adsorbs the impacts.

Design

The robust mechanical structure withstands up to 5G in any direction and 9G vertically and its design permits easy access to the connections and components during routine maintenance check-ups. The mechanical design has used the most advanced FEM analysis. The materials used are: DD12 steel for the frame, C45 steel for the shaft and cast iron or aluminum pressure die cast for the end-brackets: fans are either aluminum die casted or nylon fiber glass loaded, UL compliant materials. Rotors are dynamically balanced according grades 6.3 (up to series 32) or 2.5 (from series 34 onwards) of ISO 1940-1.

Terminals and Terminal Box

Easy access to regulators is assured through a pull out drawer or a drop down panel to allow safer adjustment. Large terminal boxes allow easy access of power cables, in the ECO43 and ECO46 higher power ranges the terminal allow the convenient choice of power cable or busbar connection with versatility of entry and connection. Current transformers are available as an option on series ECO 40, 43, 46 and 47 with single or dual output.

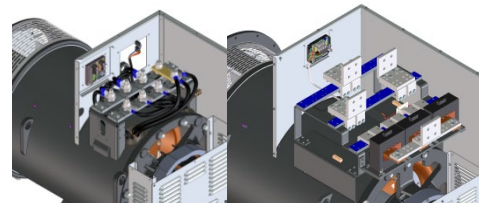

On C type family has been installed a new AVR panel. Terminal boards have been redesigned into a special L configuration, specifically to ease customer wiring; with this kind of terminal board it is possible to place a second terminal board in order to get 12 available terminals. Current transformers are available as an option on series ECO38 with single or dual output.

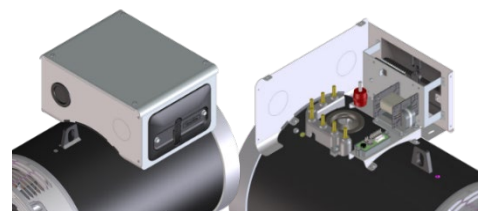

Ingress Protection

In addition to the protection on the windings themselves, alternators can increase the protection on the inlet side. Standard level is IP23 but the following solutions are also available: IP23 DP with inlet filters, IP23 with only terminal box in IP45, IP43 and IP45. Derates may be applied.

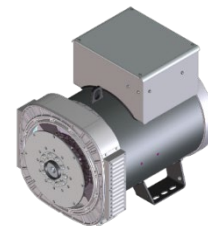

Info: https://www.meccalte.com/downloads/MA0605_Bulletin_IP.pdf

Excitation and Regulation Systems

All ECP/ECO series have MAUX auxiliary winding to power the digital regulator. Both DSR and the DER1 are available to connect to PC through the DxR2 USB interface and DxR TERMINAL software to interrogate/download alarms & settings for analysis or for cloning other regulators. DER2 has got an integrated USB connection and can be connected to the PC without any optional connection boards. More settings such as LAMS, digital RAM based synchronous external control and soft start are obtainable through the DxR connection. Simple analogue potentiometers are available for the more usual adjustments.

Excitation Systems	DSR	DER1	DER2
ECP3 to ECO38	Std	Option	Option
ECO40 to ECO46	-	Std	Option
ECO47	-	-	Std
Parallel Operation	√	√	√
Mains Parallel	√	√	√
3 Phase Sensing (rms)	-	√	√
Accuracy	+/-1%	+/-0.5%	+/-0.5%
Remote Voltage Control	√	√	√
Alarm Log	√	√	√
Analogue and Digital Configurable	√	√	√
LAMS (Load Acceptance V/f)	√	√	√
APO (Active Protection Output)	√	√	√
Soft Start	√	√	√
High dynamic response	-	-	√
USB connection without external boards	-	-	√

For a given motor start duty a smaller generator may be selected – as it has lower subtransient reactance values for non-linear loads. The whole range from 6.5 to 3400kVA is capable of >300% sustained short circuit current for up to 20 seconds.

Optional PMG

The Mecc Alte PMG is available on ECP28, ECP30, ECP32, ECP34 and ECO38 as factory-fitted option; alternatively, only the predisposition for the retrofit, for subsequent assembly, is available on option.

On ECO 40, 43 and 46 series it is available as a factory-fitted or retro-fitted options.

For ECO47 PMG is standard.

The complete AVR range is fully compatible with both MAUX and PMG systems, this minimises spare part management and flexibility of stock as one AVR suits all applications. The PMG is delivering the same amount of kVA available with the MAUX.

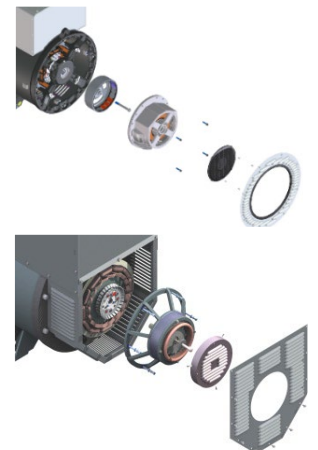

Dew Heater

Our entire range can be equipped with anti-condensation resistors of adequate power and sized for the alternator. Voltage for heaters must be specified when ordering. New cylindrical cartridge style heaters are available on request and it can be retrofitted.

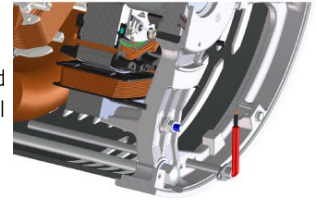

Accessories

Additional optionals can be fit on our alternator series, such as PTC thermistors or PT100 both on windings and bearings, dew heaters, high and low profile of terminal boxes (on most series), parallel devices, current and voltage transformers, air filters, IP43 and IP45 protections and many others.

For more info visit: <https://www.meccalte.com/en/products/alternators/accessories/c-type-accessories>

Deration coefficients

Altitude (meters)	Ambient temperature (Celsius)							
	25	40	45	50	55	60	65	70
≤ 1000	1.07	1	0.96	0.93	0.91	0.89	0.85	0.82
$> 1000 \leq 1500$	1.01	0.96	0.92	0.89	0.87	0.84	0.81	0.77
$> 1500 \leq 2000$	0.96	0.91	0.87	0.84	0.83	0.79	0.77	0.73
$> 2000 \leq 3000$	0.90	0.85	0.81	0.78	0.76	0.73	0.71	0.68
$> 3000 \leq 4000$	0.84	0.78	0.75	0.73	0.70	0.68	0.66	0.62
$> 4000 \leq 5000$	0.78	0.72	0.69	0.67	0.65	0.62	0.59	0.56
$> 5000 \leq 6000$	0.70	0.65	0.63	0.61	0.58	0.55	0.53	0.50

Notes on short circuit curves

The indicated coefficients have to be used to correct the three phase short circuit curves values as a function of the rated voltage.

The indicated coefficient have to be used to correct the three phase short circuit curves values as a function of the type of short circuit voltage.

50 Hz		60 Hz			3 phase	2 phase L-L	1 phase L-N
Voltage	Factor	Voltage	Factor				
380	0.93X	415	0.85X	<i>Istantaneous</i>	1X	0.87X	1.30X
400	1X	440	0.90X	<i>Minimum</i>	1X	1.80X	3.20X
415	1.04X	460	0.95X	<i>Sustained</i>	1X	1.50X	2.50X
440	1.10X	480	1X	<i>Max Duration</i>	20 sec.	10 sec.	4 sec.

All the curves are shown for series or parallel star connection at 400V 50 Hz or 480V 60 Hz. If the unit is reconnected from series to parallel star, the additional coefficient is 2X. From series star to series delta, it is 1.72X. From series star to parallel delta, it is 3.44X.

General characteristics

Pole number	4	Insulation class	H
Phase number	3	Protection class	IP23
Number of wires	12	NDE Bearing type	6207-2RS
Execution	Brushless	DE Bearing type	6309-2RS
Regulator type	DSR	Maximum Overspeed	2250
Winding pitch	2/3	Altitude	0-1000
Code voltage reference	T0405S3	Balancing	ISO1940-1

Ratings 50Hz

kVA / kW @ Temp. Rise / Ambient °C - 0.8 PF																					
		STANDBY-163/27				STANDBY-150/40				H-125/40				F-105/40				B-80/40			
Series Star Y		380V	400V	415V	440V	380V	400V	415V	440V	380V	400V	415V	440V	380V	400V	415V	440V	380V	400V	415V	440V
Parallel Star YY		190V	200V	208V	220V	190V	200V	208V	220V	190V	200V	208V	220V	190V	200V	208V	220V	190V	200V	208V	220V
Series Delta Δ		220V	230V	240V	254V	220V	230V	240V	254V	220V	230V	240V	254V	220V	230V	240V	254V	220V	230V	240V	254V
Parallel Delta ΔΔ		110V	115V	120V	127V	110V	115V	120V	127V	110V	115V	120V	127V	110V	115V	120V	127V	110V	115V	120V	127V
ECP28 1V54 C	kVA	8,2	8,2	8,2	-	7,7	7,7	7,7	-	7,5	7,5	7,5	-	6,7	6,7	6,7	-	6	6	6	-
	kW	6,6	6,6	6,6	-	6,2	6,2	6,2	-	6	6	6	-	5,4	5,4	5,4	-	4,8	4,8	4,8	-
ECP28 2V54 C	kVA	11	11	11	-	10,3	10,3	10,3	-	10	10	10	-	9,1	9,1	9,1	-	8	8	8	-
	kW	8,8	8,8	8,8	-	8,2	8,2	8,2	-	8	8	8	-	7,3	7,3	7,3	-	6,4	6,4	6,4	-
ECP28 1S4 C	kVA	13,7	13,7	13,7	-	13	13	13	-	12,5	12,5	12,5	-	11,6	11,6	11,6	-	10	10	10	-
	kW	11	11	11	-	10,4	10,4	10,4	-	10	10	10	-	9,3	9,3	9,3	-	8	8	8	-
ECP28 2S4 C	kVA	16,5	16,5	16,5	-	15,4	15,4	15,4	-	15	15	15	-	14,1	14,1	14,1	-	12	12	12	-
	kW	13,2	13,2	13,2	-	12,4	12,4	12,4	-	12	12	12	-	11,3	11,3	11,3	-	9,6	9,6	9,6	-
ECP28 3S4 C	kVA	19,2	19,2	19,2	17,5	18	18	18	16,5	17,5	17,5	17,5	16	16,5	16,5	16,5	14,9	14	14	14	12,8
	kW	15,4	15,4	15,4	14	14,4	14,4	14,4	13,2	14	14	14	12,8	13,2	13,2	13,2	11,9	11,2	11,2	11,2	10,2
ECP28 M4 C	kVA	22	22	22	20,4	20,5	20,5	20,5	19	20	20	20	18,5	18,5	18,5	18,5	17,5	16	16	16	14,8
	kW	17,6	17,6	17,6	16,3	16,4	16,4	16,4	15,2	16	16	16	14,8	14,8	14,8	14,8	14	12,8	12,8	12,8	11,9
ECP28 L4 C	kVA	27,5	27,5	27,5	-	25,5	25,5	25,5	-	25	25	25	-	23	23	23	-	20	20	20	-
	kW	22	22	22	-	20,4	20,4	20,4	-	20	20	20	-	18,4	18,4	18,4	-	16	16	16	-
ECP28 VL4 C	kVA	33	33	33	-	30,5	30,5	30,5	-	30	30	30	-	26	26	26	-	24	24	24	-
	kW	26,4	26,4	26,4	-	24,4	24,4	24,4	-	24	24	24	-	20,8	20,8	20,8	-	19,2	19,2	19,2	-

Ratings 60Hz

kVA / kW @ Temp. Rise / Ambient °C - 0.8 PF																					
		STANDBY-163/27				STANDBY-150/40				H-125/40				F-105/40				B-80/40			
Series Star Y		415V	440V	460V	480V	415V	440V	460V	480V	415V	440V	460V	480V	415V	440V	460V	480V	415V	440V	460V	480V
Parallel Star YY		208V	220V	230V	240V	208V	220V	230V	240V	208V	220V	230V	240V	208V	220V	230V	240V	208V	220V	230V	240V
Series Delta Δ		240V	254V	265V	277V	240V	254V	265V	277V	240V	254V	265V	277V	240V	254V	265V	277V	240V	254V	265V	277V
Parallel Delta ΔΔ		120V	127V	133V	138V	120V	127V	133V	138V	120V	127V	133V	138V	120V	127V	133V	138V	120V	127V	133V	138V
ECP28 1V54 C	kVA	8,8	9,3	9,9	9,9	8,3	8,7	9,3	9,3	8	8,5	9	9	7,2	7,5	8,2	8,2	6,4	6,8	7,2	7,2
	kW	7	7,4	8	8	6,6	6,9	7,5	7,5	6,4	6,8	7,2	7,2	5,8	6	6,5	6,5	5,1	5,4	5,8	5,8
ECP28 2V54 C	kVA	11,5	12,4	13,2	13,2	10,7	11,6	12,4	12,4	10,5	11,3	12	12	9,5	10	10,9	10,9	8,4	9	9,6	9,6
	kW	9,2	9,9	10,6	10,6	8,6	9,3	9,9	9,9	8,4	9	9,6	9,6	7,6	8	8,7	8,7	6,7	7,2	7,7	7,7
ECP28 1S4 C	kVA	14,3	15,3	16,5	16,5	13,3	14,3	15,5	15,5	13	13,9	15	15	12	12,5	13,9	13,9	10,4	11,1	12	12
	kW	11,4	12,2	13,2	13,2	10,7	11,4	12,4	12,4	10,4	11,1	12	12	9,6	10	11	11	8,3	8,9	9,6	9,6
ECP28 2S4 C	kVA	17	18,1	19,8	19,8	15,9	16,8	18,5	18,5	15,4	16,4	18	18	14,6	15,4	16,8	16,8	12,4	13,1	14,4	14,4
	kW	13,6	14,4	15,8	15,8	12,7	13,4	14,8	14,8	12,4	13,1	14,4	14,4	11,6	12,3	13,4	13,4	9,9	10,5	11,5	11,5
ECP28 3S4 C	kVA	19,8	21,1	23	23	18,5	19,7	21,6	21,6	18	19	21	21	17	18	19,6	19,6	14,4	15,3	16,8	16,8
	kW	15,8	16,8	18,5	18,5	14,8	15,7	17,3	17,3	14,4	15,3	16,8	16,8	13,6	14,4	15,6	15,6	11,5	12,2	13,4	13,4
ECP28 M4 C	kVA	23,1	26,4	26,4	26,4	21,5	24,6	24,6	24,6	21	24	24	24	19	22	22	22	16,8	19,2	19,2	19,2
	kW	18,5	21	21	21	17,2	19,7	19,7	19,7	16,8	19,2	19,2	19,2	15,2	17,6	17,6	17,6	13,4	15,4	15,4	15,4
ECP28 L4 C	kVA	28,6	30,3	33	33	26,5	28	30,6	30,6	26	27,5	30	30	24	25,5	27,5	27,5	20,8	22	24	24
	kW	22,9	24,2	26,4	26,4	21,2	22,4	24,5	24,5	20,8	22	24	24	19,2	20,4	22	22	16,6	17,6	19,2	19,2
ECP28 VL4 C	kVA	36,3	39,6	39,6	39,6	33,5	36,6	36,6	36,6	33	36	36	36	29	32	32	32	26,4	29	29	29
	kW	29	31,7	31,7	31,7	26,8	29,3	29,3	29,3	26,4	28,8	28,8	28,8	23,2	25,6	25,6	25,6	21,1	23	23	23

Reactance & Time constants- Class H / 400V

Unsaturated (ref. EN60034-4)			ECP28 1V54 C	ECP28 2V54 C	ECP28 1S4 C	ECP28 2S4 C	ECP28 3S4 C	ECP28 M4 C	ECP28 L4 C	ECP28 VL4 C
X_d	Direct-axis synchronous reactance	%	233,2	228,8	207,7	196,9	217,3	200,6	215,5	185,8
X'_d	Direct-axis transient reactance	%	20,2	20	18,3	17,3	18,7	18,7	18,9	17,4
X''_d	Direct-axis subtransient reactance	%	14,4	14,3	11,8	11,2	12,7	10,6	10,7	9,9
X_q	Quadrature-axis synchronous reactance	%	85,5	83,4	71,1	67,6	79,9	87,1	88,6	80,1
X'_q	Quadrature-axis transient reactance	%	85,5	83,4	71,1	67,6	79,9	87,1	88,6	80,1
X''_q	Quadrature-axis subtransient reactance	%	30	28,2	24,8	23,5	26,4	24,4	24,4	21,5
X₂	Negative-sequence reactance	%	21,6	20,7	17,7	16,8	19	16,9	17	15,1
X₀	Zero sequence reactance	%	4,41	4,11	3,49	3,32	3,97	3,67	3,63	3,17
Saturated										
X_d	Direct-axis synchronous reactance	%	198,2	194,5	176,5	167,4	184,7	170,5	183,2	157,9
X'_d	Direct-axis transient reactance	%	17,2	17	15,6	14,7	15,9	15,9	16,1	14,8
X''_d	Direct-axis subtransient reactance	%	12,2	12,2	10	9,52	10,8	9,01	9,09	8,42
X_q	Quadrature-axis synchronous reactance	%	72,7	70,9	60,4	57,5	67,9	74	75,3	68,1
X'_q	Quadrature-axis transient reactance	%	72,7	70,9	60,4	57,5	67,9	74	75,3	68,1
X''_q	Quadrature-axis subtransient reactance	%	25,5	24	21,1	20	22,4	20,7	20,7	18,3
X₂	Negative-sequence reactance	%	18,4	17,6	15	14,3	16,2	14,4	14,4	12,8
X₀	Zero sequence reactance	%	4,41	4,11	3,49	3,32	3,97	3,67	3,63	3,17
K_{cc}	Short circuit ratio		0,5	0,51	0,57	0,6	0,54	0,59	0,55	0,63
T'_d	Transient time constant	sec	0,062	0,057	0,066	0,063	0,055	0,048	0,054	0,051
T''_d	Subtransient time constant	sec	0,023	0,025	0,028	0,026	0,02	0,015	0,015	0,013
T'_{do}	Open circuit time constant	sec	0,72	0,66	0,75	0,71	0,64	0,51	0,61	0,54
T_a	Armature time constant	sec	0,09	0,009	0,009	0,009	0,009	0,01	0,01	0,01

Additional information - Class H / 400V

I_o	Excitation current at no load	A	0,7	0,8	0,8	0,7	0,6	0,6	0,7	0,7
I_c	Excitation current at full load	A	3,0	2,9	3,2	2,6	2,0	1,8	1,9	2,4
Overload										
Overload per 20 sec. PRP or 10 sec. COP		%	300							
Heat dissipation		W	1009	1302	1587	1857	2148	2391	2831	3242
Telephone Harmonic Factor - THF		%	<2	<2	<2	<2	<2	<2	<2	<2
Waveform Distors.(THD) full load LL/LN		%	1,5 / 1,5	1,7 / 1,6	1,8 / 1,7	1,5 / 1,5	1,7 / 1,6	1,5 / 1,6	1,5 / 1,4	2,1 / 2
Waveform Distors.(THD) no load LL/LN		%	3,5 / 3,5	3,4 / 3,3	3,5 / 3,5	3,4 / 3,4	3,5 / 3,4	3,2 / 3,2	3 / 2,9	3 / 3

Reactance & Time constants- Class H / 480V

Unsaturated (ref. EN60034-4)			ECP28 1V54 C	ECP28 2V54 C	ECP28 1S4 C	ECP28 2S4 C	ECP28 3S4 C	ECP28 M4 C	ECP28 L4 C	ECP28 VL4 C
X_d	Direct-axis synchronous reactance	%	233,2	228,8	207,7	196,9	217,3	200,6	215,5	185,8
X'_d	Direct-axis transient reactance	%	20,2	20	18,3	17,3	18,7	18,7	18,9	17,4
X''_d	Direct-axis subtransient reactance	%	14,4	14,3	11,8	11,2	12,7	10,6	10,7	9,9
X_q	Quadrature-axis synchronous reactance	%	85,5	83,4	71,1	67,6	79,9	87,1	88,6	80,1
X'_q	Quadrature-axis transient reactance	%	85,5	83,4	71,1	67,6	79,9	87,1	88,6	80,1
X''_q	Quadrature-axis subtransient reactance	%	30	28,2	24,8	23,5	26,4	24,4	24,4	21,5
X₂	Negative-sequence reactance	%	21,6	20,7	17,7	16,8	19	16,9	17	15,1
X₀	Zero sequence reactance	%	4,41	4,11	3,49	3,32	3,97	3,67	3,63	3,17
Saturated										
X_d	Direct-axis synchronous reactance	%	198,2	194,5	176,5	167,4	184,7	170,5	183,2	157,9
X'_d	Direct-axis transient reactance	%	17,2	17	15,6	14,7	15,9	15,9	16,1	14,8
X''_d	Direct-axis subtransient reactance	%	12,2	12,2	10	9,52	10,8	9,01	9,09	8,42
X_q	Quadrature-axis synchronous reactance	%	72,7	70,9	60,4	57,5	67,9	74	75,3	68,1
X'_q	Quadrature-axis transient reactance	%	72,7	70,9	60,4	57,5	67,9	74	75,3	68,1
X''_q	Quadrature-axis subtransient reactance	%	25,5	24	21,1	20	22,4	20,7	20,7	18,3
X₂	Negative-sequence reactance	%	18,4	17,6	15	14,3	16,2	14,4	14,4	12,8
X₀	Zero sequence reactance	%	4,41	4,11	3,49	3,32	3,97	3,67	3,63	3,17
K_{cc}	Short circuit ratio		0,5	0,51	0,57	0,6	0,54	0,59	0,55	0,63
T'_d	Transient time constant	sec	0,062	0,057	0,066	0,063	0,055	0,048	0,054	0,051
T''_d	Subtransient time constant	sec	0,023	0,025	0,028	0,026	0,02	0,015	0,015	0,013
T'_{do}	Open circuit time constant	sec	0,72	0,66	0,75	0,71	0,64	0,51	0,61	0,54
T_a	Armature time constant	sec	0,09	0,009	0,009	0,009	0,009	0,01	0,01	0,01

Additional information - Class H / 480V

I_o	Excitation current at no load	A	0,7	0,8	0,8	0,7	0,6	0,6	0,7	0,7
I_c	Excitation current at full load	A	3,0	2,9	3,2	2,6	2,0	1,8	1,9	2,4
Overload										
Overload per 20 sec. PRP or 10 sec. COP		%	300							
Heat dissipation		W	1124	1460	1761	2001	2291	2397	2936	3271
Telephone Interference Factor - TIF			<45	<45	<45	<45	<45	<45	<45	<45
Waveform Distors.(THD) full load LL/LN		%	1,5 / 1,5	1,7 / 1,6	1,8 / 1,7	1,5 / 1,5	1,7 / 1,6	1,5 / 1,6	1,5 / 1,4	2,1 / 2
Waveform Distors.(THD) no load LL/LN		%	3,5 / 3,5	3,4 / 3,3	3,5 / 3,5	3,4 / 3,4	3,5 / 3,4	3,2 / 3,2	3 / 2,9	3 / 3

Efficiencies @ 50Hz

Models		380V 50Hz					400V 50Hz					415V 50Hz					440V 50Hz				
		0.25	0.5	0.75	1	1.1	0.25	0.5	0.75	1	1.1	0.25	0.5	0.75	1	1.1	0.25	0.5	0.75	1	1.1
ECP28 1V54 C	%	85,6	87,2	86,9	85,9	85,4	85,8	87,1	86,8	85,6	85,1	86,0	87,1	86,9	85,9	85,4	-	-	-	-	-
ECP28 2V54 C	%	85,7	87,4	87,3	86,3	85,8	85,9	87,3	87,2	86,0	85,5	86,1	87,3	87,3	86,3	85,8	-	-	-	-	-
ECP28 154 C	%	86,4	87,9	87,6	86,6	86,1	86,6	87,8	87,5	86,3	85,8	86,8	87,8	87,6	86,6	86,1	-	-	-	-	-
ECP28 254 C	%	86,8	88,5	88,3	87,2	86,7	87,4	88,3	87,8	86,6	86,1	87,5	88,2	87,9	86,8	86,3	-	-	-	-	-
ECP28 354 C	%	87,8	88,7	88,1	87,0	86,5	88,0	88,6	88,0	86,7	86,2	88,2	88,6	88,1	87,0	86,5	88,7	88,9	88,4	87,2	86,8
ECP28 M4 C	%	88,1	89,0	88,3	87,3	86,8	88,3	89,1	88,2	87,0	86,5	88,5	89,1	88,5	87,3	86,8	89,0	89,2	88,6	87,5	87,1
ECP28 L4 C	%	88,9	89,9	89,0	87,6	87,1	89,0	89,8	88,9	87,6	87,1	89,0	89,8	88,8	87,3	86,9	-	-	-	-	-
ECP28 VL4 C	%	89,3	90,3	89,4	87,9	87,4	89,4	90,2	89,3	87,9	87,4	89,4	90,2	89,4	88,2	87,8	-	-	-	-	-

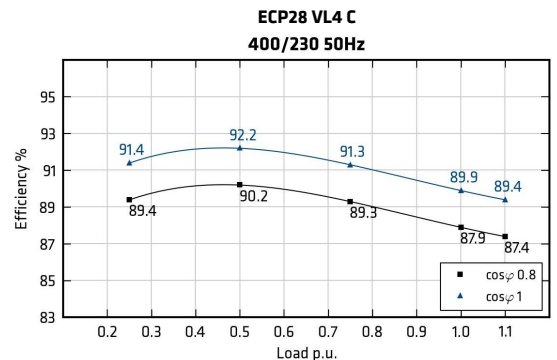
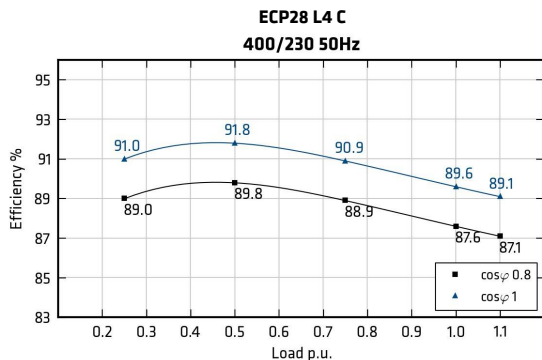
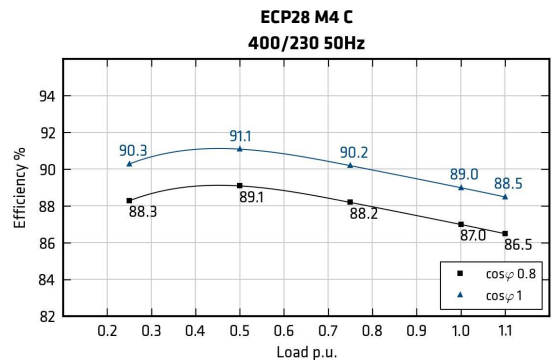
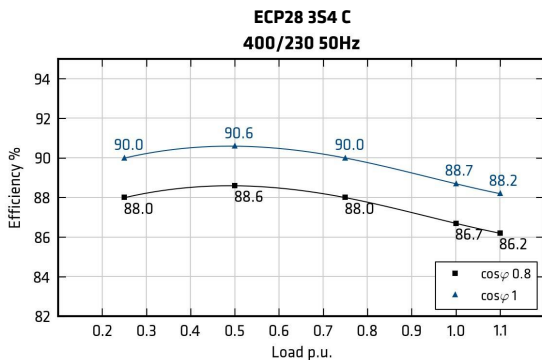
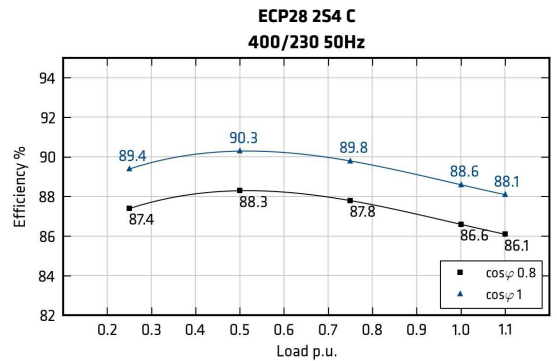
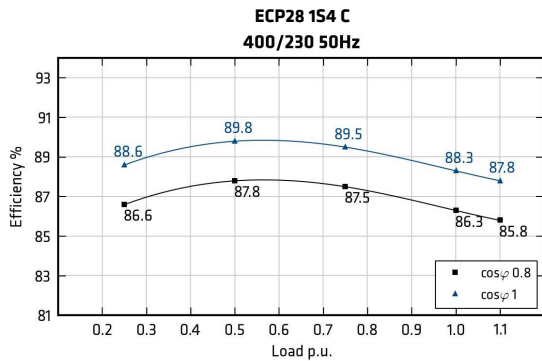
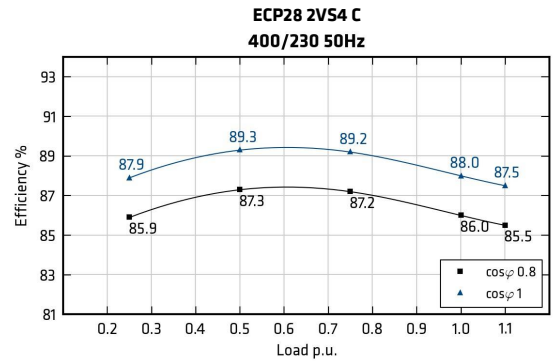
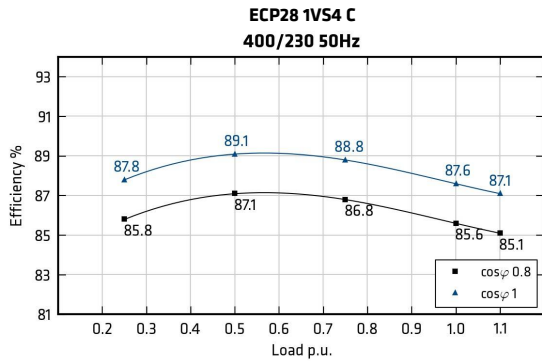

Efficiencies @ 60Hz

Models		415V 60Hz					440V 60Hz					460V 60Hz					480V 60Hz				
		0.25	0.5	0.75	1	1.1	0.25	0.5	0.75	1	1.1	0.25	0.5	0.75	1	1.1	0.25	0.5	0.75	1	1.1
ECP28 1V54 C	%	85,2	87,0	87,2	86,6	86,1	85,4	87,0	86,9	86,3	85,9	84,9	86,8	87,1	86,6	86,2	85,2	86,9	87,0	86,5	86,1
ECP28 2V54 C	%	85,4	87,3	87,7	86,9	86,4	85,6	87,3	87,4	86,6	86,2	85,1	87,1	87,6	86,9	86,5	85,4	87,2	87,5	86,8	86,4
ECP28 1S4 C	%	86,1	88,0	88,2	87,3	86,8	86,3	88,0	87,9	87,0	86,6	85,8	87,8	88,1	87,3	86,9	86,1	87,9	88,0	87,2	86,8
ECP28 2S4 C	%	86,9	88,7	89,2	88,5	88,0	87,4	88,7	88,4	87,4	87,0	86,3	88,1	88,6	87,9	87,5	86,8	88,4	88,4	87,8	87,4
ECP28 3S4 C	%	87,2	88,6	88,7	88,1	87,6	87,3	88,6	88,4	87,8	87,4	86,8	88,4	88,6	88,1	87,7	87,1	88,5	88,5	88,0	87,6
ECP28 M4 C	%	89,1	89,8	89,7	89,0	88,5	88,7	89,7	89,5	88,9	88,5	88,8	89,6	89,6	89,0	88,6	88,7	89,7	89,5	88,9	88,5
ECP28 L4 C	%	89,9	90,5	90,1	89,0	88,4	90,0	90,6	89,8	88,5	88,0	89,6	90,3	90,0	88,9	88,3	89,5	90,4	89,9	89,1	88,6
ECP28 VL4 C	%	90,2	91,0	90,5	89,3	88,7	90,5	91,1	90,2	88,8	88,2	89,8	90,8	90,4	89,2	88,6	89,7	90,9	90,3	89,4	88,9

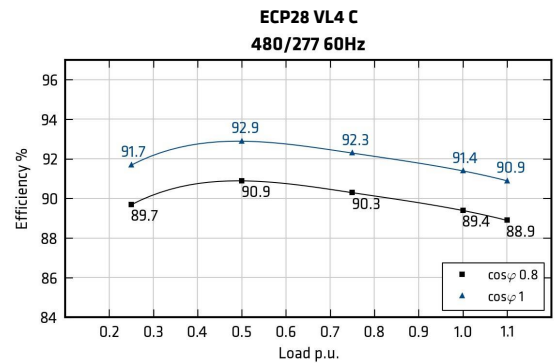
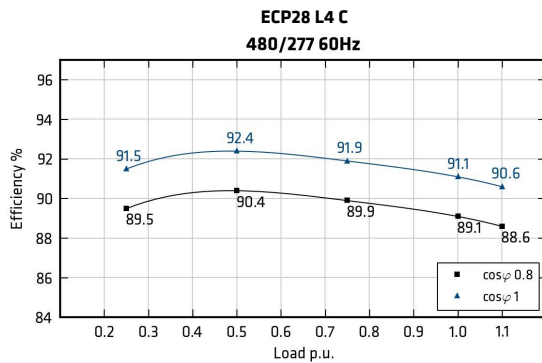
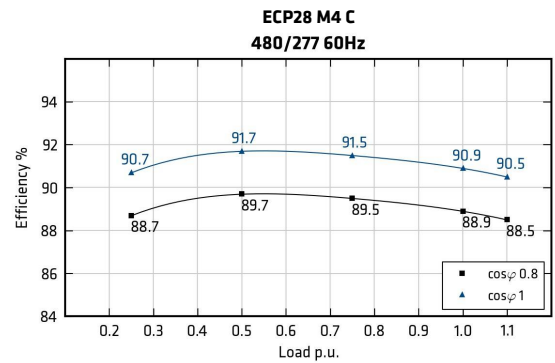
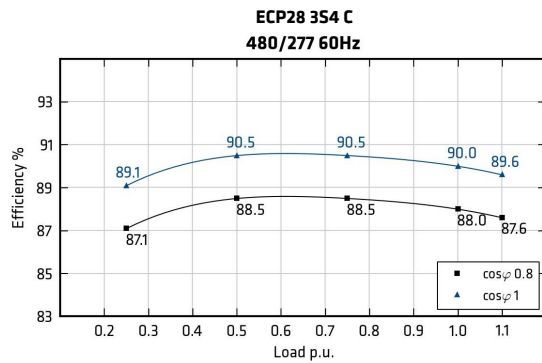
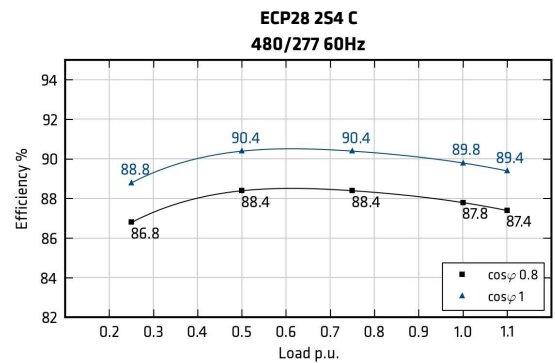
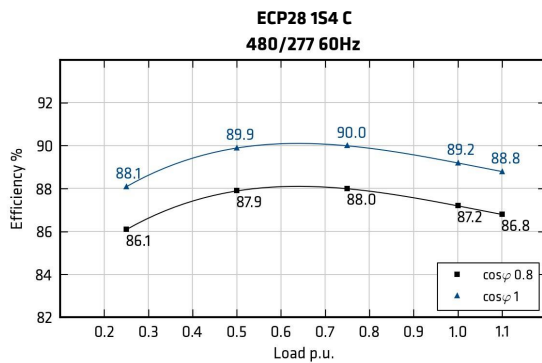
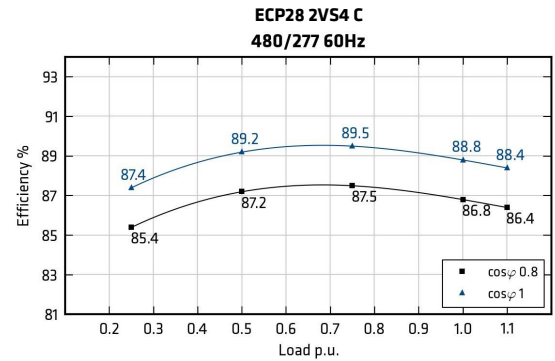
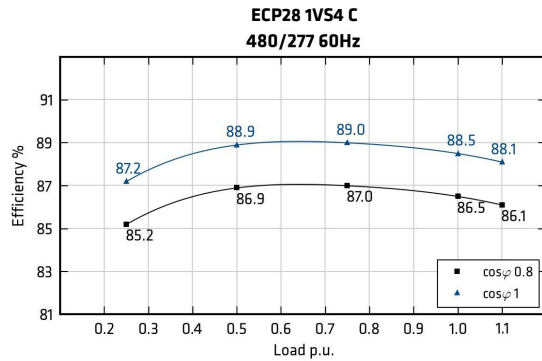

Transients voltage

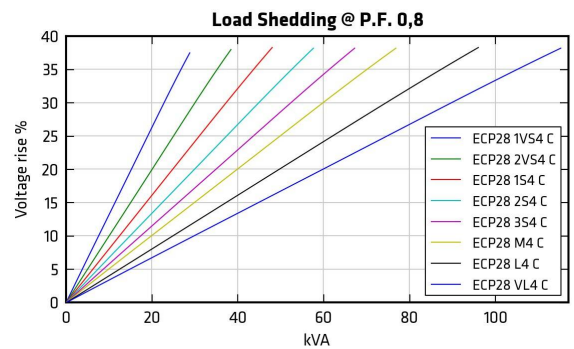
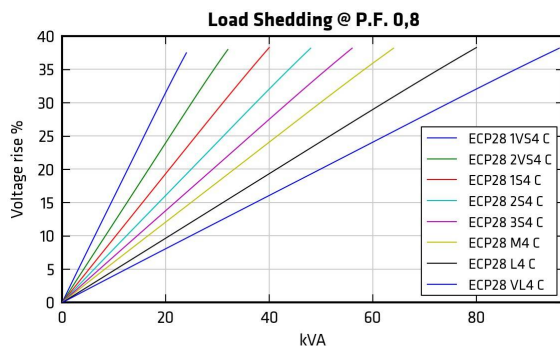
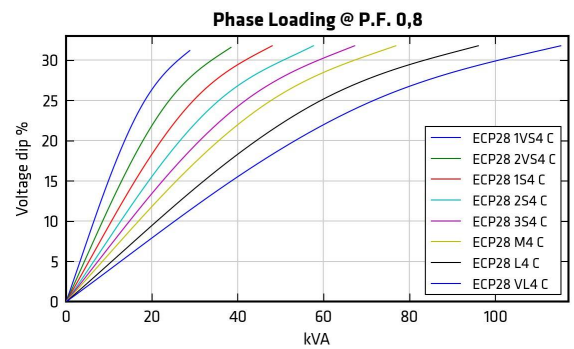
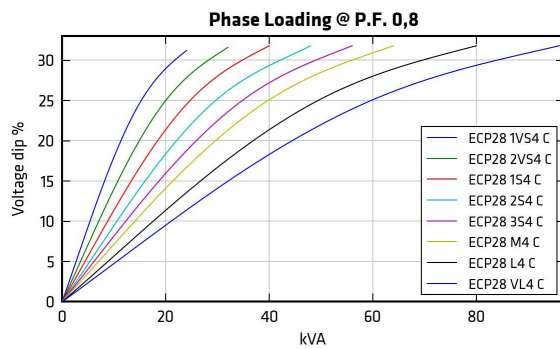
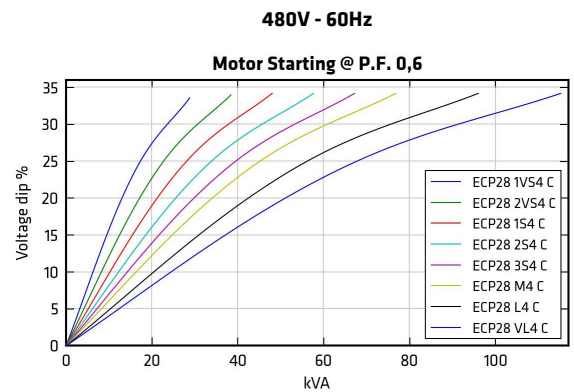
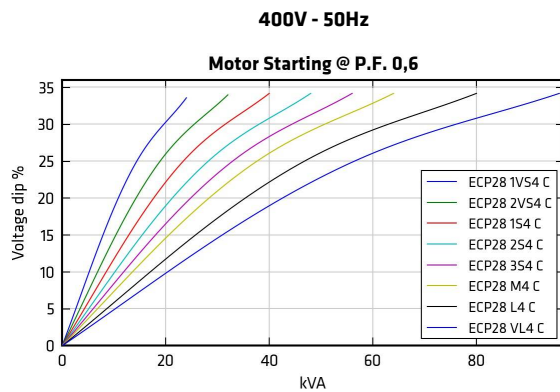

In order to scale transient curves as a function of a power factor or voltage if not indicated, please proceed as follows:

Power Factor coefficient corrector (PFCC), to be used on power factor 0.6 curves:

$$PFCC = \sin(\text{ARCCos}(PF_{\text{new}})) / 0.8$$

Example. The PFCC at power factor 0.3 is 1.192 [$PFCC = \sin(\text{ARCCos}(0.3)) / 0.8$]. This means that the voltage fall at a given power at pf 0.3 is equivalent to the one that can be read on the pf 0.6 curve if the load is considered 1.192 times bigger (19% higher value.).

In this example, a 100 kVA load insertion at pf 0.3 is equivalent in voltage fall to a 119kVA load insertion at pf 0.6.

Voltage coefficient corrector (VCC):

$$VCC = (400/V_{\text{new}})^2 \text{ if } 50 \text{ Hz}; VCC = (480/V_{\text{new}})^2 \text{ if } 60 \text{ Hz}$$

Example. VCC at 415V 60 Hz is 1.338 [$VCC = (480/415)^2$]. This means that the voltage fall at a given power at 415V is equivalent to the one that can be read on the power factor 0.6 curve if the load is considered 1.338 times bigger (33% higher value.).

In this example, a 100 kVA load insertion at 415V is equivalent in voltage fall to a 133kVA load insertion at 480V.

50Hz Short circuit decrement curves - No load excitation at rated speed

ECP28 1VS4 C

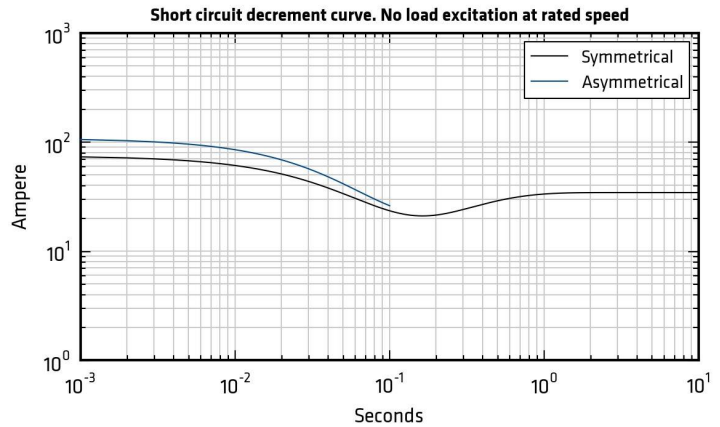

ECP28 2VS4 C

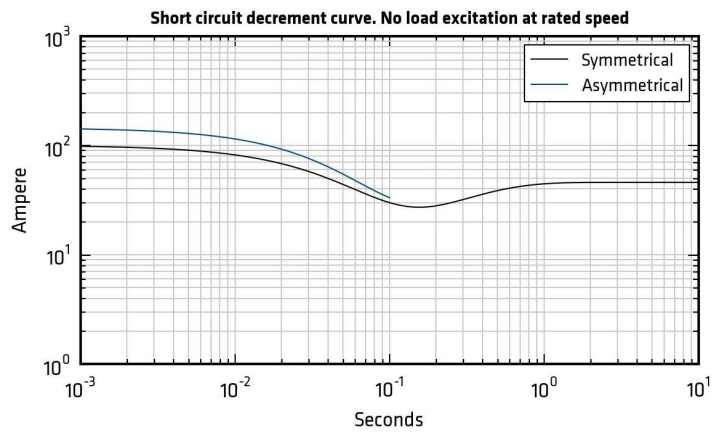

ECP28 1S4 C

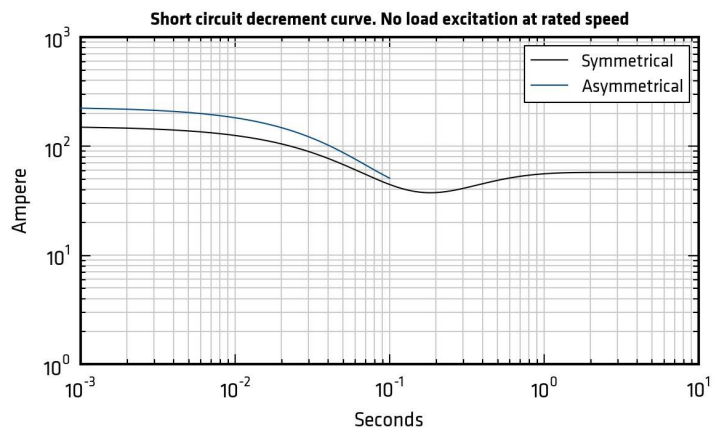

ECP28 2S4 C

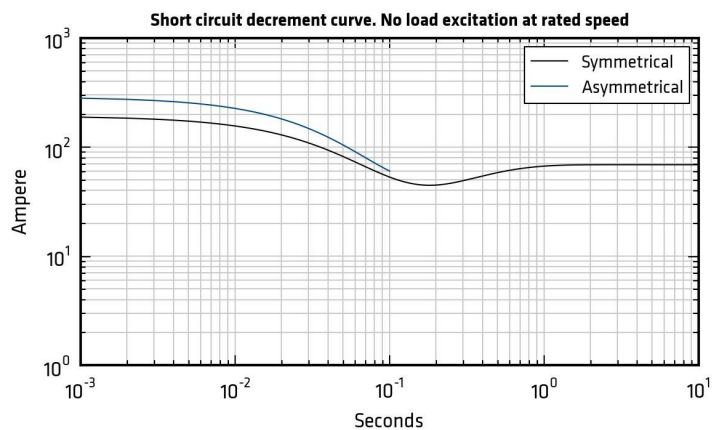

*Please refer to tables at page 6

50Hz Short circuit decrement curves - No load excitation at rated speed

ECP28 3S4 C

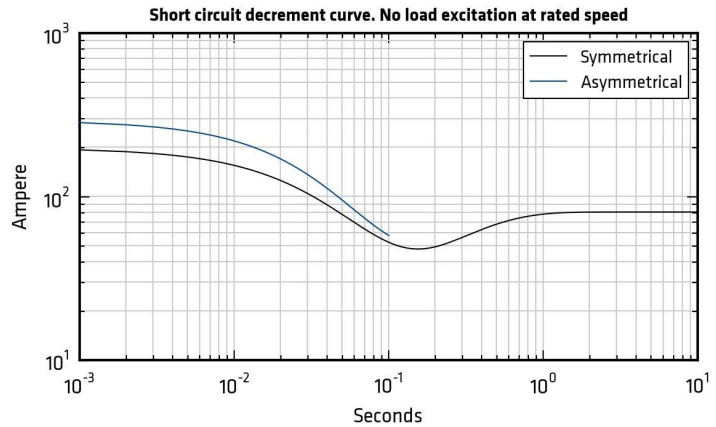

ECP28 M4 C

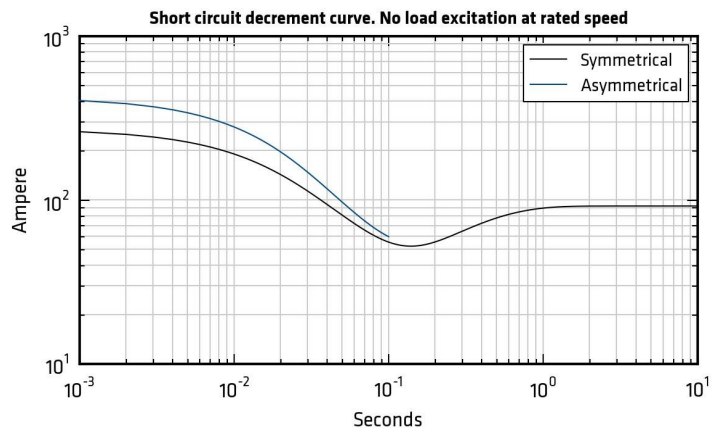

ECP28 L4 C

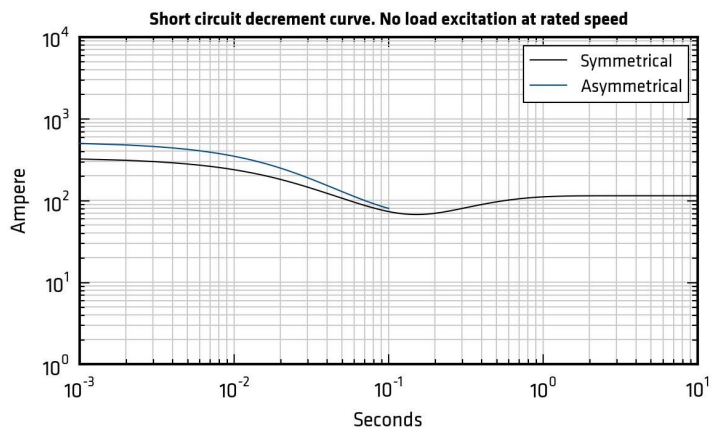

ECP28 VL4 C

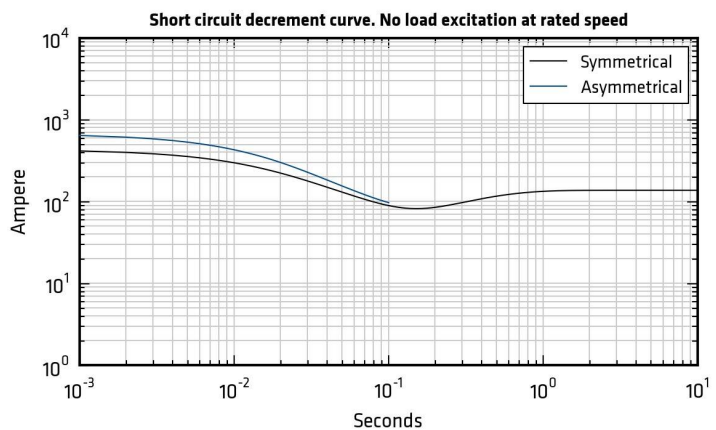

*Please refer to tables at page 6

60Hz Short circuit decrement curves - No load excitation at rated speed

ECP28 1VS4 C

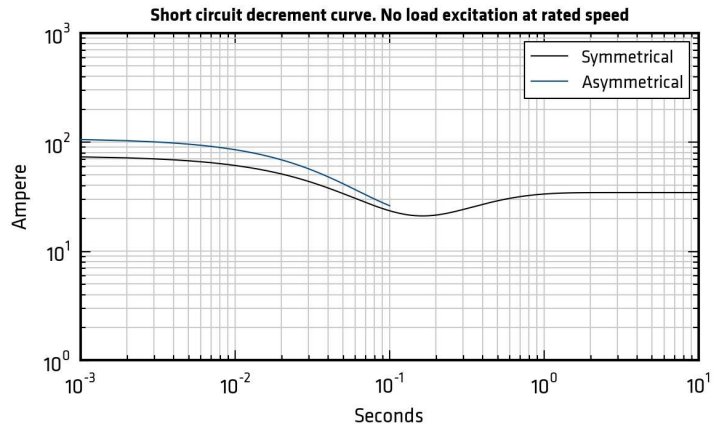

ECP28 2VS4 C

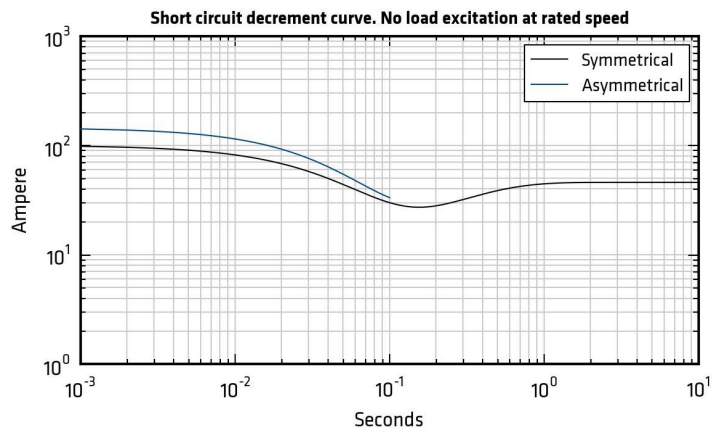

ECP28 1S4 C

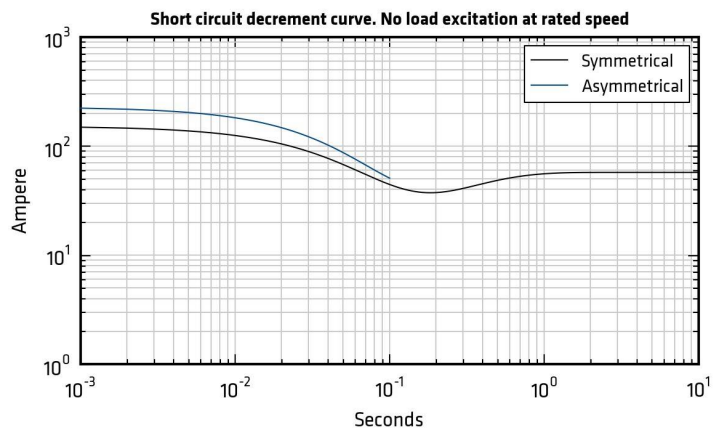

ECP28 2S4 C

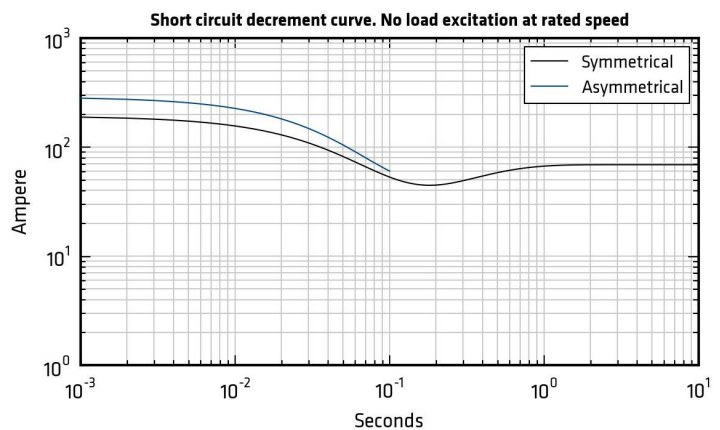

*Please refer to tables at page 6

60Hz Short circuit decrement curves - No load excitation at rated speed

ECP28 3S4 C

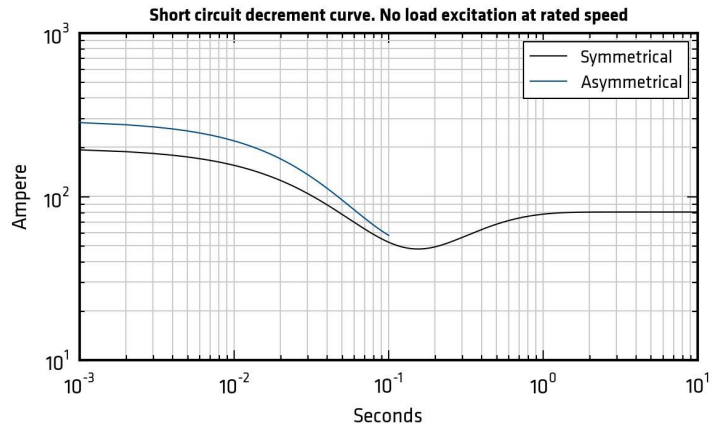

ECP28 M4 C

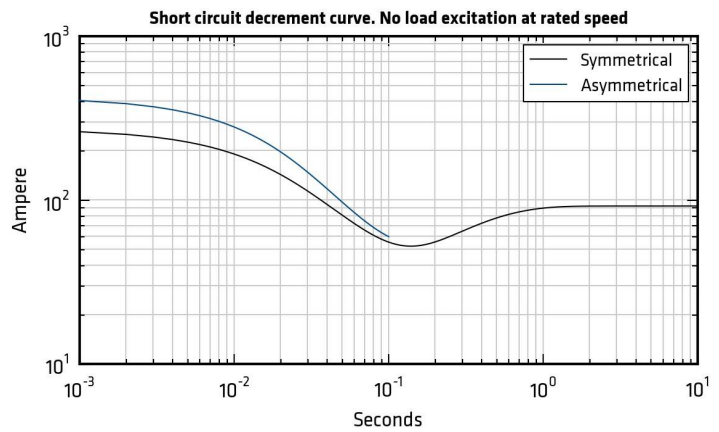

ECP28 L4 C

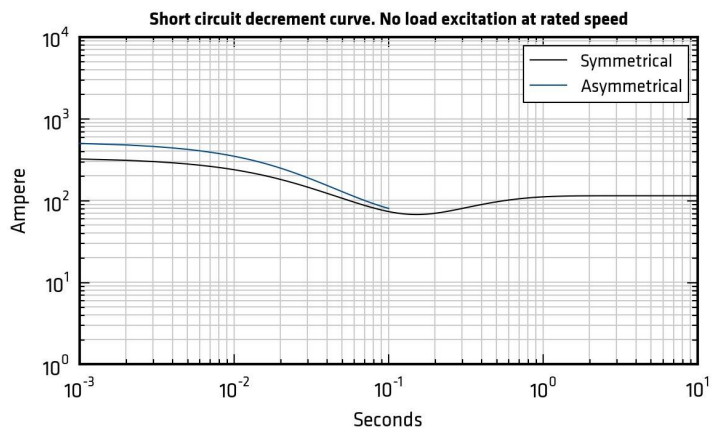

ECP28 VL4 C

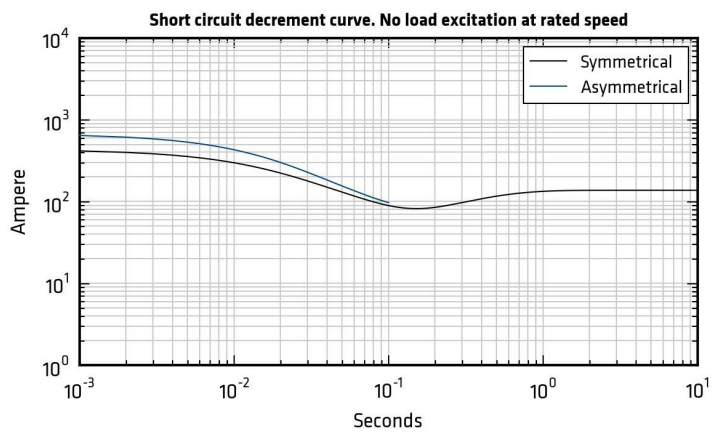

*Please refer to tables at page 6

Additional Characteristics

Data	ECP28 1V54 C		ECP28 2V54 C		ECP28 1S4 C		ECP28 2S4 C		ECP28 3S4 C		ECP28 M4 C		ECP28 L4 C		ECP28 VL4 C	
	50Hz	60Hz	50Hz	60Hz	50Hz	60Hz	50Hz	60Hz	50Hz	60Hz	50Hz	60Hz	50Hz	60Hz	50Hz	60Hz
Damper cage	Aluminium															
Stator Winding Resistance (20°C)	Ω		1,101	0,737	0,542	0,396	0,347	0,276	0,183	0,141						
Rotor Winding Resistance (20°C)	Ω		0,904	0,986	1,067	1,123	1,204	1,314	1,505	1,75						
Stator Exciter Resistance (20°C)	Ω		9,6	9,6	9,6	9,6	9,6	9,6	9,6	9,6						
Rotor Exciter Resistance (20°C)	Ω		0,384	0,384	0,384	0,384	0,384	0,384	0,384	0,384						
Auxiliary Winding Resistance (20°C)	Ω		6,056	5,27	4,837	4,459	1,624	1,479	1,444	1,434						
Weight of complete generator	kg		73,0	79,1	87,4	91,5	96,9	106,0	121,9	141,8						
Unbalanced magnetic pull	kN/mm		2,9	3,0	2,8	2,9	3,0	3,6	4,3	4,6						
Air flow	m ³ /min		6,6	8,0	6,6	8,0	6,6	8,0	6,6	8,0	6,6	8,0	6,6	8,0	6,6	8,0
Noise level at 1m/7m	dB(A)		68/57	71/61	68/57	71/61	68/57	71/61	68/57	71/61	68/57	71/61	68/57	71/61	68/57	71/61

PQ Diagram

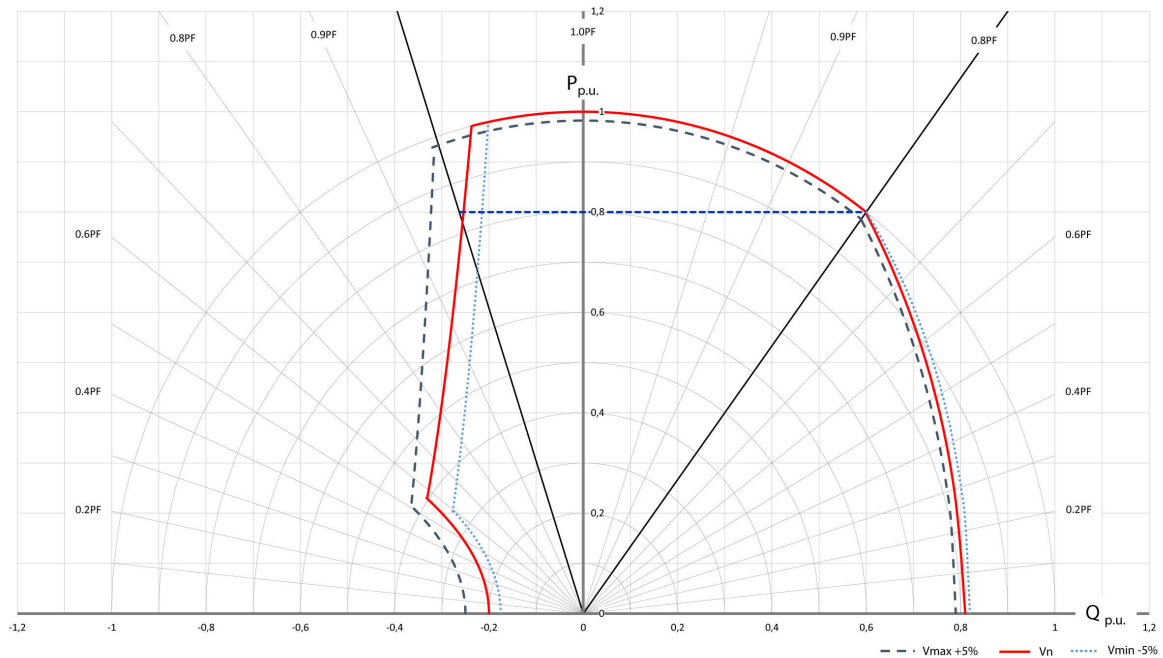

MOMENTS OF INERTIA - SINGLE BEARING

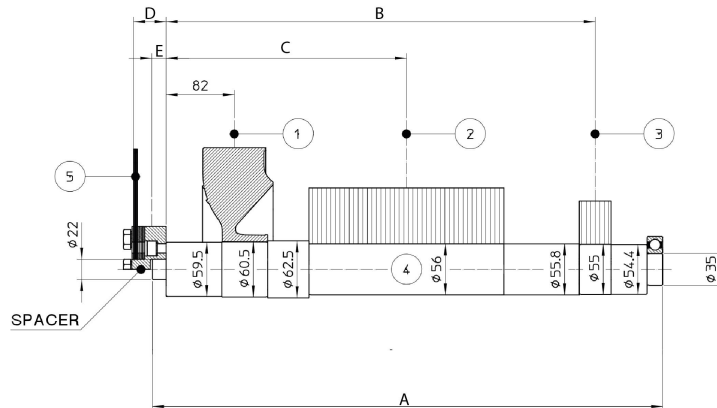

POS. COMPONENT	1 FAN		2 MAIN ROTOR		3 EXCITER ROTOR		4 SHAFT*		TOTAL		DIMENSION TYPE	A [mm]	B [mm]	C [mm]	SAEN°	5	SHAFTS COUPLING FLEXPLATE			
	WEIGHT [kg]	J [kgm²]	WEIGHT [kg]	J [kgm²]	WEIGHT [kg]	J [kgm²]	WEIGHT [kg]	J [kgm²]	WEIGHT [kg]	J [kgm²]							D	E	WEIGHT [kg]	J [kgm²]
ECP28 M2 C	0,7	0,0046	19,4	0,0712	4,4	0,0138	9,1	0,0037	33,6	0,0933	ECP28 M2 C	479,5	390,5	226	6 1/2	4	2	1,4	0,0068	
ECP28 1L2 C			23	0,0847			9,7	0,0038	37,8	0,1069	ECP28 1L2 C	514,5	425,5	241	7 1/2	4	2	1,7	0,0104	
ECP28 2L2 C			24,3	0,0894			9,7	0,0038	39,1	0,1116	ECP28 2L2 C	559,5	470,5	268,5	8	35,6	28,3	2,8	0,0158	
ECP28 VL2 C			30	0,1104			10,6	0,0042	45,7	0,133	ECP28 VL2 C	559,5	470,5	268,5	10	27,6	22,9	3,3	0,0303	
ECP28 1VS4 C	0,7	0,0046	10,1	0,0406	4,4	0,0138	7,9	0,0031	23,1	0,0621	ECP28 1VS4 C	419,5	330,5	201	11 1/2	14	11,2	3,6	0,0471	
ECP28 2VS4 C			12	0,0484			7,9	0,0031	25	0,0699	ECP28 2VS4 C	459,5	370,5	193,5						
ECP28 1S4 C			14	0,0561			8,7	0,0034	27,8	0,0779	ECP28 1S4 C			226						
ECP28 2S4 C			15,2	0,0613			8,7	0,0034	29	0,0831	ECP28 2S4 C			221						
ECP28 3S4 C			17,2	0,069			8,7	0,0034	31	0,0908	ECP28 3S4 C			213,5						
ECP28 M4 C			19,8	0,0794			9,1	0,0035	34	0,1013	ECP28 M4 C	479,5	390,5	223,5						
ECP28 L4 C			24,5	0,0981			9,7	0,0038	39,3	0,1203	ECP28 L4 C	514,5	425,5	241						
ECP28 VL4 C			30,5	0,1214			10,6	0,0042	46,2	0,144	ECP28 VL4 C	559,5	470,5	263,5						

80616_01_ECP28C_MD35

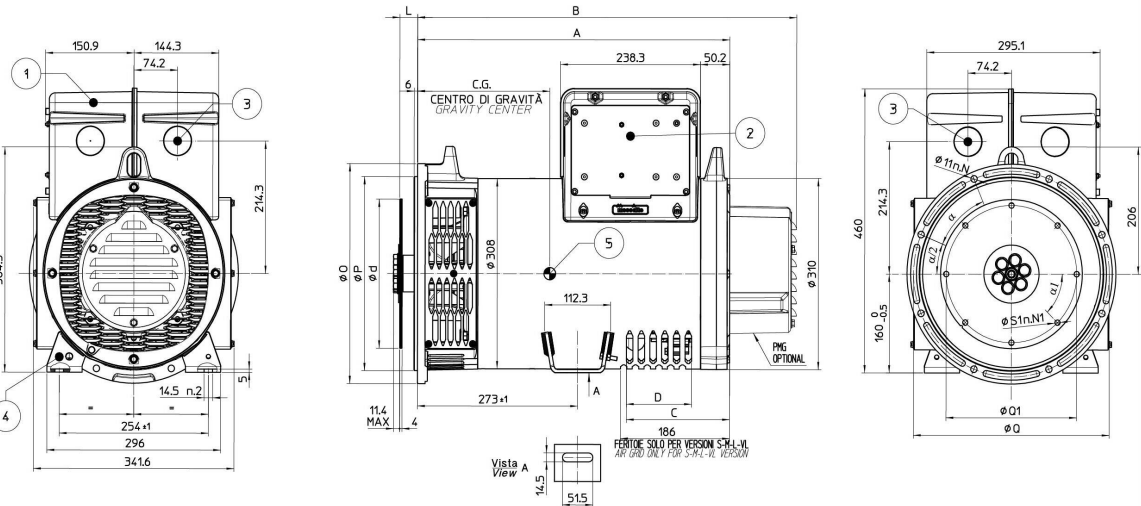

SERIE / SERIES	MODELLO / MODEL	A	B	C	D	C.G.
ECP28C/2 MD35	M	452	566	116	51	218,1
	1L	487	601	136	71	233,6
	2L	487	601	136	71	236,1
	VL	532	646	176	111	258,1

SAE N.	FLANGIA/FLANGE BRIDE/FLANSCH				
	O	P	Q	□	N
5	395	314,3	333,4	45°	8
4	403	362,0	381,0	30°	12
3	451	409,6	428,6	30°	12
2	490	447,7	466,7	30°	12

SAE N.	GIUNTI A DISCHI / DISC COUPLING DISQUE DE MONOPALIER / SCHEIBENKUPPLUNG					
	d	L	Q1	S1	□1	N1
6 1/2	215,90	30,2	200,00	9	60°	6
7 1/2	241,30	30,2	222,25	9	45°	8
8	263,52	62,0	244,47	11	60°	6
10	314,32	53,8	295,27	11	45°	8
11 1/2	352,42	39,6	333,37	11	45°	8

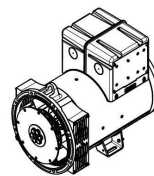

- 1) COPERCHIO REMOVIBILE PER ACCESSO AI TERMINALI PRINCIPALI
REMOVABLE COVER FOR ACCESS TO MAIN TERMINALS
- 2) PANNELLO REMOVIBILE PER ACCESSO AL REGOLATORE
REMOVABLE PANEL FOR ACCESS TO AVR
- 3) PRE-TAGLIO PER INGRESSO CAVI Ø48mm
PRE-CUT FOR CABLE ENTRY Ø48mm
- 4) VITE M6 PER MESSA A TERRA
SCREW M6 FOR GROUNDING
- 5) CENTRO DI GRAVITA' IN CONFIGURAZIONE SAE 3 FLYWHEEL 115
GRAVITY CENTER IN CONFIGURATION SAE 3 FLYWHEEL 115

80578_03_ECP28C_MD35

Mecc Alte SpA (HQ)

Via Roma
20 - 36051 Creazzo
Vicenza - ITALY
T: +39 0444 396111
E: info@meccalte.it
aftersales@meccalte.it

Mecc Alte Portable

Via Roma
20 - 36051 Creazzo
Vicenza - ITALY
T: +39 0444 396111
E: info@meccalte.it

Mecc Alte Power Products srl

Via Melaro
2 - 36075 Montecchio
Maggiore (VI) - ITALY
T: +39 0444 1831295
E: info@meccalte.it

Zanardi Alternatori srl

Via Dei Laghi
48/B - 36077 Altavilla
Vicenza - ITALY
T: +39 0444 370799
E: info@zanardialternatori.it

United Kingdom

Mecc Alte U.K. LTD
6 Lands' End Way
Oakham
Rutland LE15 6RF
T: +44 (0) 1572 771160
E: info@meccalte.co.uk

Spain

Mecc Alte España S.A.
C/ Rio Taibilla, 2
Polig. Ind. Los Valeros
03178 Benijofar (Alicante)
T: +34 (0) 96 6702152
E: info@meccalte.es

China

Mecc Alte Alternator Haimen LTD
755 Nanghai East Rd
Jiangsu HEDZ 226100 PRC
T: +86 (0) 513 82325758
E: info@meccalte.cn

India

Mecc Alte India PVT LTD
Plot NO: 1, Sanaswadi
Talegaon
Dhamdhare Road Taluka:
Shirur, District:
Pune - 412208
Maharashtra, India
T: +91 2137 619600
E: info@meccalte.in

U.S.A. and Canada

Mecc Alte Inc.
1229 Adams Drive
McHenry, IL, 60051
T: +1 815 344 0530
E: info@meccalte.us

Germany

Mecc Alte Generatoren GmbH
Bucher Hang 2
D-87448 Waltenhofen
T: +49 (0)831 540755 0
E: info@meccalte.de

Australia

Mecc Alte Alternators PTY LTD
10 Duncan Road, PO Box 1046
Dry Creek, 5094, South
Australia
T: +61 (0) 8 8349 8422
E: info@meccalte.com.au

France

Mecc Alte International S.A.
Z.E.La Gagnerie
16330 ST.Amant de Boixe
T: +33 (0) 545 397562
E: info@meccalte.fr

Far East

Mecc Alte (F.E.) PTE LTD
19 Kian Teck Drive
Singapore 628836
T: +65 62 657122
E: info@meccalte.com.sg



www.meccalte.com