



Totally Focused. Totally Independent.

Technical Specification

CTP3 4



**The world's largest
independent producer of
alternators 1 – 5,000kVA**

All electrical and mechanical data contained in this document is provided for reference only and represents typical values under optimal operating conditions. Actual performances may be subjected to cumulative tolerances or variances due to materials, construction or other specific operating and loading conditions, in accordance with IEC 60034.

Mecc Alte S.p.A. reserves the right to change specifications without notice. The information contained in this document does not constitute a guarantee of performance for any specific application. For specific technical information, please contact your local Mecc Alte office.

This document is the property of Mecc Alte S.p.A. – All rights reserved. Reproduction, distribution, or transmission of this publication, in whole or in part, is prohibited without prior written consent.

Regulations and Certifications

The alternators are designed, built and tested in accordance with **ISO 9001**, within a certified quality management system. The entire range meets the most common international specifications, including:

- ▶ CEI 2-3, IEC 34-1, EN 60034-1, VDE 0530
- ▶ BS 4999-5000, NF 51.111, NEMA MG 1-2011
- ▶ ISO 8528-3

In addition, they comply with specific regulations for particular markets, such as:

- ▶ UL 1446, UL 1004-4, UL 1004-B
- ▶ CAN/CSA-C22.2 No14-95 / No100-95

The ECP and ECO series comply with EEC directives **2006/42/EC (Machinery Directive)**, **2014/35/EC (Low Voltage Directive)**, **2014/30/EC (Electromagnetic Compatibility Directive)**, **2011/65/EC (RoHS 2)** and **2015/863 (RoHS 3)**.

Windings and performance

All alternators are equipped with **reduced pitch windings (2/3)**. This configuration allows:

- ▶ The elimination of triple harmonics in the voltage waveform
- ▶ Reduction of neutral currents in parallel operation

All models, except the **ECP3 series**, are equipped with an aluminum or copper **cushioning cage** to ensure greater stability during load transients.

- ▶ 12 reconnectable wires:
 - 50 Hz - from 380 V to 440 V and from 220/110 V to 240/120 V (with possible derating)
 - 60 Hz - from 380 V to 480 V and from 220/110 V to 240/120 V (with possible derating)
- ▶ 6 reconnectable wires:
 - 50 Hz - from 380 V to 440 V and from 220 V to 240 V (with possible derating)
 - 60 Hz - from 380 V to 480 V and from 220 V to 240 V (with possible derating)

Winding configurations	Standard		Special (dedicated)			
	12 reconnectable wires	6 reconnectable wires	380 V and 600 V 60 Hz	690V 50/60Hz	220-240V 1ph 50Hz	220-240V 1ph 60Hz
ECP3 to ECO38 & (NPE)	●	○	○	○	○	○
ECO40 to ECO46	○	●	○	○	○ *	○ *
ECO47	● 4 wires		○	○	-	-
THD (Total Harmonic Distortion)	Typically <3.5% at full load L-L	Typically <3.0% at full load L-L	Typically <3.5% at full load L-L	Typically <3.5% at full load L-L	Typically <4.5% at full load L-N	Typically <4.5% at full load L-N
Interference suppression	VDE 0875 G/N/K, EN61000-6-3, EN61000-6-2, others available on request					

* Only up to ECO40 series ● Standard ○ Optional

Insulating Materials and Electrical Performance

- ▶ **Insulation Class:** H on the entire range
- ▶ **Efficiency:** High efficiency as standard
- ▶ **Motor Start:** Inrush current >300% for 20 seconds
- ▶ **THD (Total Harmonic Distortion):**
 - <3.5% L-L typical (three-phase windings)
 - <4.5% L-N typical (single-phase windings)

Winding protection

Winding protection is crucial to ensure the longevity of the generator based on environmental conditions and electrical stress.

Protection Level	Standard	Standard+	Grey	Grey+	Total+	V-Type
Treated Components	Active parts	Exciter stator	Main stator + exciter	Stator + Exciter	Stator + Exciter + Rotor	Complete system
Type of Treatment	Impregnation resin only	Resin + Grey paint EG43	Grey paint EG43	Stator (EG43) + Exciter (Black severe ep.)	Black protection (stators) + EG43 (rotating parts)	Double VPI, Anti-Corona Wire, Double Layer Black
Series/Typical Application	ECP3, ECP4 (Standard Use)	ECP28, 30, 32	Marine Applications / NPE, ECO, HCP	Harsh industrial environments	Extreme/abusive conditions	Harsh Environments (Extended Warranty)

Detail of specific treatments

- ▶ **Grey paint EG43:** Standard protection against moisture and contaminants.
- ▶ **Black Protection:** Advanced physical barrier against chemicals and high humidity.
- ▶ **V-Type Treatment:** Includes vacuum impregnation (VPI), internal stator insulation, and corona-resistant materials for maximum reliability.

For more information visit: [Insulation_System_Guide](#)

Construction

The robust mechanical structure withstands up to 5G in any direction and 9G vertically, and its design allows easy access to connections and components during routine maintenance checks. The mechanical design used the most advanced FEM techniques. The materials used are: DD12 steel for the frame, C45 steel for the shaft and cast iron or die-cast aluminum for the end brackets: the fans are made of die-cast aluminum and nylon reinforced with fiberglass, UL compliant materials. The rotors are dynamically balanced according to ISO 1940-1 grades 6.3 (up to series 32) or 2.5 (series 34 onwards).

Terminals and terminal blocks

Easy access to the regulators is ensured by a pull-out drawer or drop-down panel to allow for safer adjustment. Large terminal blocks allow easy access of power cables, in the higher power ranges ECO43 and ECO46 terminals allow convenient choice of power cable or busbar connection with input and connection versatility. Current transformers are available as an option on the ECO 40, 43, 46 and 47 series with single or dual output.

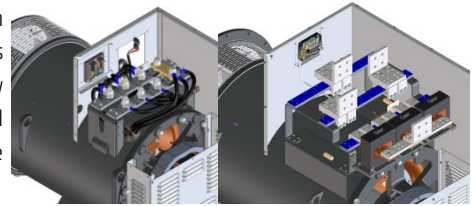

A new AVR panel has been installed on the Type-C family. The terminal blocks have been redesigned in a special "L" configuration, specifically to facilitate connections with customers; With this type of terminal block, a second terminal block can be positioned in order to obtain 12 terminals available. Current transformers are available as an option on the ECO38 series with single or dual output.

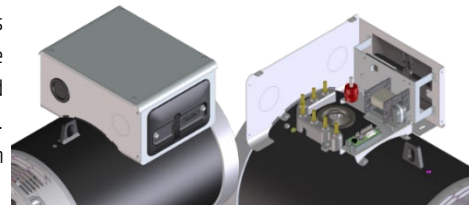

Protection for the environment

In addition to the protection on the windings themselves, alternators can have a higher degree of protection. The standard level is IP23 but the following solutions are also available: IP23 DP with ingress filters, IP23 with terminal box only in IP45, IP43 and IP45. Downgrades may apply. For more information visit: [Bulletin_IP](#)

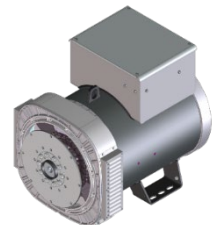

Optional PMG

The MeccAlte PMG is optionally available factory-fitted on ECP28, ECP30, ECP32, ECP34 and ECO38; Alternatively, only the preparation for future mounting is optional.



On the ECO 40, 43 and 46 series it is optionally available factory-fitted or retrofitted. On the ECO47 the PMG is standard.

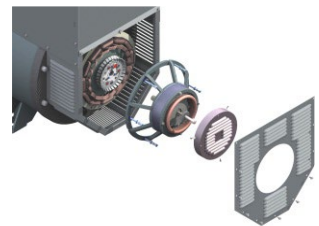

The entire AVR range is fully compatible with MAUX and PMG systems, minimizing spare parts management and inventory flexibility, as one AVR adapts to all applications. The PMG delivers the same amount of kVA as the MAUX.

Anti-condensation heater

Our entire range can be equipped with anti-condensation heaters of adequate power and sized to the alternator. The voltage for heaters must be specified when ordering. New cylindrical cartridge heaters are available on request and can be retrofitted.

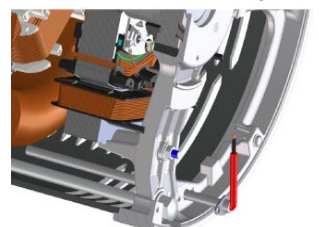

Accessories

Additional optional can be mounted on our alternator series, such as PTC or PT100 thermistors on both windings and bearings, anti-condensation heaters, high and low profile terminal blocks (on most series), parallel devices, current and voltage transformers, air filters, IP43 and IP45 protections and many more. For more information visit: [C-type-accessories](#)

Excitation and regulation systems

All ECP/ECO series are equipped with MAUX auxiliary winding to power the digital controller.

DxR

Both the DSR and DER1 are available for PC connection via the DxR2 USB interface and DxR TERMINAL software to query/download alarms and settings for analysis or for cloning other controllers. DER2 has a built-in USB connection and can be connected to your PC without any optional connection card. Through the DxR connection, other settings such as LAMS, synchronous external control based on digital RAM, and soft start can be achieved. Simple analog potentiometers are available for the most common adjustments.

MxK

The digital controllers of the MxK series (M2K, M2Ks, M3K, M3Ks, M3KSHD) are configurable via the MeccAlte App for PC or mobile devices, using the USB2MxK (USB) or MxKconnect (Wi-Fi) accessories. The M3KSHD model integrates a USB port for direct connection to the PC, without the need for optional cards. The M2Ks, M3Ks and M3KSHD models also support CAN Bus communication (SAE J-1939) for integration with MeccAlte GC controllers. Software-accessible features include LAMS, external voltage control ($\pm 10V$), soft start, and PID autotuning. The controller records up to 64 alarms in E2PROM memory and provides the current status via A ALARMS address. There are analog potentiometers for VOLT, STAB, AMP, and DROOP (the latter on M3K, M3Ks, and M3KSHD models only). The M3KSHD includes High Dynamic Response (HDR) for a quick rush of excitement. All MxK regulators are equipped with protections against over/under excitation, overcurrent, V/f, short circuit and power overvoltage.

Regulator	M2K	M2Ks	M3K	M3Ks	M3KsHD	DSR	DER1	DER2
ECP3 to ECO38 & (NPE)	●	○	○	○	○	○	○	○
ECO40 to ECO46	○	○	●	○	○	○	○	○
ECO47	○	○	○	○	●	○	○	○
Parallel operation	-	-	√	√	√	√	√	√
Network Parallel	-	-	√	√	√	√	√	√
Reference 3 phase (rms)	-	-	√	√	√	-	√	√
Accuracy	+/-0.5%	+/-0.5%	+/-0.5%	+/-0.5%	+/-0.5%	+/-1%	+/-0.5%	+/-0.5%
Remote voltage control	√	√	√	√	√	√	√	√
Alarm log	√	√	√	√	√	√	√	√
Analog and digital configurable	√	√	√	√	√	√	√	√
LAMS (Load Acceptance V/f)	√	√	√	√	√	√	√	√
APO (Active Protection Output)	-	-	-	-	√	√	√	√
Soft start	√	√	√	√	√	√	√	√
High Dynamic Response	-	-	-	-	√	-	-	√
USB connection without external cards	-	-	-	-	√	-	-	√

● Standard ○ Optional √ Available

Derating coefficients

Altitude (meters)	Ambient temperature (Celsius)							
	25	40	45	50	55	60	65	70
≤ 1000	1.07	1	0.96	0.93	0.91	0.89	0.85	0.82
$> 1000 \leq 1500$	1.01	0.96	0.92	0.89	0.87	0.84	0.81	0.77
$> 1500 \leq 2000$	0.96	0.91	0.87	0.84	0.83	0.79	0.77	0.73
$> 2000 \leq 3000$	0.90	0.85	0.81	0.78	0.76	0.73	0.71	0.68
$> 3000 \leq 4000$	0.84	0.78	0.75	0.73	0.70	0.68	0.66	0.62
$> 4000 \leq 5000$	0.78	0.72	0.69	0.67	0.65	0.62	0.59	0.56
$> 5000 \leq 6000$	0.70	0.65	0.63	0.61	0.58	0.55	0.53	0.50

Notes on short-circuit curves

The coefficients indicated must be used to correct the values of the three-phase short-circuit curves as a function of the nominal voltage.

The indicated coefficient must be used to correct the values of the three-phase short-circuit curves as a function of the type of short-circuit voltage.

50 Hz		60 Hz			3 Steps	2 L-L phases	1 L-N phase
Voltage	Factor	Voltage	Factor				
380	0.93x	415	0.85x	Instant	1x	0.87x	1.30x
400	1x	440	0.90x	Minimum	1x	1.80x	3.20x
415	1.04x	460	0.95x	Supported	1x	1.50x	2.50x
440	1.10x	480	1x	Maximum duration	20 s	10 s	4 s

All curves are shown for star connection in series or parallel at 400V 50 Hz or 480V 60 Hz. If the unit is reconnected from series to star parallel, the additional coefficient is 2x. From the star series to the delta series, it is 1.72x. From star in series to parallel triangle, it is 3.44x.

A smaller generator can be selected for a given engine starting service, as it has lower subtransient reactance values for nonlinear loads. The entire range from 6.5 to 3400 kVA is capable of delivering a sustained short-circuit current of >300% for up to 20 seconds.

MeccAlte Tools

This section provides direct access to professional tools developed to support alternator selection, sizing and configuration. These tools ensure solutions that are aligned with the electrical and mechanical requirements of each project.

Key features

With a data-driven approach, you can optimize performance and reduce scaling risks:

- ▶ **Targeted Selection:** Identify the ideal alternator based on load profiles and operating conditions.
- ▶ **Power Calculations:** performs the sizing of the engine and alternator respecting the electrical constraints.
- ▶ **Parameter Verification:** Controls engine starting capability and handling of unbalanced and distorted loads.
- ▶ **PMG Configuration:** Configure permanent magnet alternators for AC/DC outputs or battery chargers.

For more information visit: [MeccAlte Tools](#)

General characteristics

Pole number	4	Insulation class	H
Phase number	3	Protection class	IP23
Number of wires	6	NDE Bearing type	6305-2RS
Execution	Brushless	DE Bearing type	6308-2RS
Regulator type	AMP. TRASFORMER	Maximum Overspeed	2250
Winding pitch	2/3	Altitude	0-1000
Code voltage reference	T0405S3	Balancing	ISO1940-1

Ratings 50Hz

kVA / kW @ Temp. Rise / Ambient °C - 0.8 PF																					
	STANDBY-163/27				STANDBY-150/40				H-125/40				F-105/40				B-80/40				
Series	380V	400V	415V	440V	380V	400V	415V	440V	380V	400V	415V	440V	380V	400V	415V	440V	380V	400V	415V	440V	
Parallel Star YY	190V	200V	208V	220V	190V	200V	208V	220V	190V	200V	208V	220V	190V	200V	208V	220V	190V	200V	208V	220V	
Series Delta Δ	220V	230V	240V	254V	220V	230V	240V	254V	220V	230V	240V	254V	220V	230V	240V	254V	220V	230V	240V	254V	
Parallel Delta ΔΔ	110V	115V	120V	127V	110V	115V	120V	127V	110V	115V	120V	127V	110V	115V	120V	127V	110V	115V	120V	127V	
CTP3 154	kVA	7	7	7	-	6,8	6,8	6,8	-	6,5	6,5	6,5	-	6,3	6,3	6,3	-	5,3	5,3	5,3	-
	kW	5,6	5,6	5,6	-	5,4	5,4	5,4	-	5,2	5,2	5,2	-	5	5	5	-	4,2	4,2	4,2	-
CTP3 254	kVA	8,6	8,6	8,6	-	8,4	8,4	8,4	-	8	8	8	-	7,5	7,5	7,5	-	6,4	6,4	6,4	-
	kW	6,9	6,9	6,9	-	6,7	6,7	6,7	-	6,4	6,4	6,4	-	6	6	6	-	5,1	5,1	5,1	-
CTP3 1L4	kVA	10,8	10,8	10,8	-	10,5	10,5	10,5	-	10	10	10	-	9	9	9	-	8,8	8,8	8,8	-
	kW	8,6	8,6	8,6	-	8,4	8,4	8,4	-	8	8	8	-	7,2	7,2	7,2	-	7	7	7	-
CTP3 2L4	kVA	14	14	14	-	13,7	13,7	13,7	-	13	13	13	-	12	12	12	-	10,4	10,4	10,4	-
	kW	11,2	11,2	11,2	-	11	11	11	-	10,4	10,4	10,4	-	9,6	9,6	9,6	-	8,3	8,3	8,3	-

Ratings 60Hz

kVA / kW @ Temp. Rise / Ambient °C - 0.8 PF																					
	STANDBY-163/27				STANDBY-150/40				H-125/40				F-105/40				B-80/40				
Series	415V	440V	460V	480V	415V	440V	460V	480V	415V	440V	460V	480V	415V	440V	460V	480V	415V	440V	460V	480V	
Parallel Star YY	208V	220V	230V	240V	208V	220V	230V	240V	208V	220V	230V	240V	208V	220V	230V	240V	208V	220V	230V	240V	
Series Delta Δ	240V	254V	265V	277V	240V	254V	265V	277V	240V	254V	265V	277V	240V	254V	265V	277V	240V	254V	265V	277V	
Parallel Delta ΔΔ	120V	127V	133V	138V	120V	127V	133V	138V	120V	127V	133V	138V	120V	127V	133V	138V	120V	127V	133V	138V	
CTP3 154	kVA	-	8,4	8,4	8,4	-	8,2	8,2	8,2	-	7,8	7,8	7,8	-	7	7	7	-	6,3	6,3	6,3
	kW	-	6,7	6,7	6,7	-	6,6	6,6	6,6	-	6,2	6,2	6,2	-	5,6	5,6	5,6	-	5	5	5
CTP3 254	kVA	-	10,3	10,3	10,3	-	10,1	10,1	10,1	-	9,6	9,6	9,6	-	8,6	8,5	8,5	-	7,7	7,7	7,7
	kW	-	8,2	8,2	8,2	-	8,1	8,1	8,1	-	7,7	7,7	7,7	-	6,9	6,8	6,8	-	6,2	6,2	6,2
CTP3 1L4	kVA	-	12,9	12,9	12,9	-	12,6	12,6	12,6	-	12	12	12	-	11	11	11	-	9,6	9,6	9,6
	kW	-	10,3	10,3	10,3	-	10,1	10,1	10,1	-	9,6	9,6	9,6	-	8,8	8,8	8,8	-	7,7	7,7	7,7
CTP3 2L4	kVA	-	16,7	16,7	16,7	-	16,4	16,4	16,4	-	15,6	15,6	15,6	-	15	15	15	-	12,5	12,5	12,5
	kW	-	13,4	13,4	13,4	-	13,1	13,1	13,1	-	12,5	12,5	12,5	-	12	12	12	-	10	10	10

Reactance & Time constants- Class H / 400V

Unsaturated (ref. EN60034-4)			CTP3 154	CTP3 254	CTP3 1L4	CTP3 2L4
X_d	Direct-axis synchronous reactance	%	188	206	191	141
X'_d	Direct-axis transient reactance	%	18,5	18,5	11,7	14,4
X''_d	Direct-axis subtransient reactance	%	15,6	13,3	13,5	10
X_q	Quadrature-axis synchronous reactance	%	59,5	61	62	71
X'_q	Quadrature-axis transient reactance	%	59,5	61	62	71
X''_q	Quadrature-axis subtransient reactance	%	75,6	72,2	70,9	52,4
X₂	Negative-sequence reactance	%	15,5	15,8	17,4	16,8
X₀	Zero sequence reactance	%	6,4	5,5	6,2	5,2
Saturated						
X_d	Direct-axis synchronous reactance	%	159,8	175,1	162,4	119,8
X'_d	Direct-axis transient reactance	%	15,7	15,7	9,94	12,2
X''_d	Direct-axis subtransient reactance	%	13,3	11,3	11,5	8,5
X_q	Quadrature-axis synchronous reactance	%	50,6	51,8	52,7	60,4
X'_q	Quadrature-axis transient reactance	%	50,6	51,8	52,7	60,4
X''_q	Quadrature-axis subtransient reactance	%	64,3	61,4	60,3	44,5
X₂	Negative-sequence reactance	%	13,2	13,4	14,8	14,3
X₀	Zero sequence reactance	%	6,4	5,5	6,2	5,2
K_{cc}	Short circuit ratio		0,63	0,57	0,62	0,83
T'_d	Transient time constant	sec	0,026	0,017	0,036	0,044
T''_d	Subtransient time constant	sec	0,025	0,011	0,013	0,009
T'_{do}	Open circuit time constant	sec	0,71	0,73	0,79	0,84
T_a	Armature time constant	sec	0,011	0,012	0,046	0,011

Additional information - Class H / 400V

I_o	Excitation current at no load	A	0,36	0,36	0,34	0,35
I_c	Excitation current at full load	A	1,1	1,1	1,5	1,2
Overload						
Overload per 20 sec. PRP or 10 sec. COP			300			
Heat dissipation		W	1149	1265	1368	1743
Telephone Harmonic Factor - THF		%	<2	<2	<2	<2
Waveform Distors.(THD) full load LL/LN		%	2,8 / 2,6	2,8 / 2,4	2,3 / 2	2,8 / 2,7
Waveform Distors.(THD) no load LL/LN		%	2,93 / 2,5	2,7 / 2,5	2,6 / 2,6	2,2 / 2

Reactance & Time constants- Class H / 480V

Unsaturated (ref. EN60034-4)			CTP3 154	CTP3 254	CTP3 1L4	CTP3 2L4
X_d	Direct-axis synchronous reactance	%	188	206	191	141
X'_d	Direct-axis transient reactance	%	18,5	18,5	11,7	14,4
X''_d	Direct-axis subtransient reactance	%	15,6	13,3	13,5	10
X_q	Quadrature-axis synchronous reactance	%	59,5	61	62	71
X'_q	Quadrature-axis transient reactance	%	59,5	61	62	71
X''_q	Quadrature-axis subtransient reactance	%	75,6	72,2	70,9	52,4
X₂	Negative-sequence reactance	%	15,5	15,8	17,4	16,8
X₀	Zero sequence reactance	%	6,4	5,5	6,2	5,2
Saturated						
X_d	Direct-axis synchronous reactance	%	159,8	175,1	162,4	119,8
X'_d	Direct-axis transient reactance	%	15,7	15,7	9,94	12,2
X''_d	Direct-axis subtransient reactance	%	13,3	11,3	11,5	8,5
X_q	Quadrature-axis synchronous reactance	%	50,6	51,8	52,7	60,4
X'_q	Quadrature-axis transient reactance	%	50,6	51,8	52,7	60,4
X''_q	Quadrature-axis subtransient reactance	%	64,3	61,4	60,3	44,5
X₂	Negative-sequence reactance	%	13,2	13,4	14,8	14,3
X₀	Zero sequence reactance	%	6,4	5,5	6,2	5,2
K_{cc}	Short circuit ratio		0,63	0,57	0,62	0,83
T'_d	Transient time constant	sec	0,026	0,017	0,036	0,044
T''_d	Subtransient time constant	sec	0,025	0,011	0,013	0,009
T'_{do}	Open circuit time constant	sec	0,71	0,73	0,79	0,84
T_a	Armature time constant	sec	0,011	0,012	0,046	0,011

Additional information - Class H / 480V

I_o	Excitation current at no load	A	0,36	0,36	0,3	0,32
I_c	Excitation current at full load	A	1,1	1,1	1,4	1,2
Overload						
Overload per 20 sec. PRP or 10 sec. COP			%			
			300			
Heat dissipation		W	1278	1355	1498	1865
Telephone Interference Factor - TIF			<45	<45	<45	<45
Waveform Distors.(THD) full load LL/LN		%	2,8 / 2,6	2,8 / 2,4	2,3 / 2	2,8 / 2,7
Waveform Distors.(THD) no load LL/LN		%	2,93 / 2,5	2,7 / 2,5	2,6 / 2,6	2,2 / 2

Efficiencies @ 50Hz

Models		380V 50Hz					400V 50Hz					415V 50Hz					440V 50Hz				
		0.25	0.5	0.75	1	1.1	0.25	0.5	0.75	1	1.1	0.25	0.5	0.75	1	1.1	0.25	0.5	0.75	1	1.1
CTP3 1S4	%	75,1	78,4	83,0	81,6	81,1	75,0	78,5	83,2	81,9	81,3	75,0	78,3	82,9	81,6	81,0	-	-	-	-	-
CTP3 2S4	%	75,4	79,8	83,8	83,8	83,4	75,5	80,0	84,0	83,5	83,2	75,2	79,6	83,6	83,6	83,3	-	-	-	-	-
CTP3 1L4	%	81,0	83,9	85,8	85,1	84,8	81,1	84,0	86,0	85,4	85,0	80,8	83,8	85,7	85,0	84,6	-	-	-	-	-
CTP3 2L4	%	81,8	84,8	86,4	86,9	85,4	82,0	85,0	86,5	87,0	85,9	81,6	84,7	86,3	86,8	85,2	-	-	-	-	-

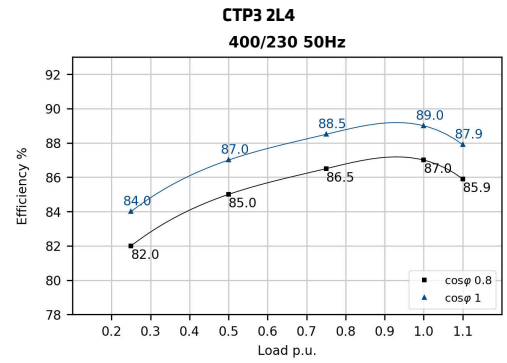
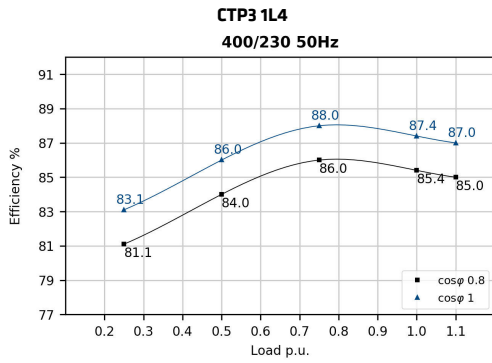
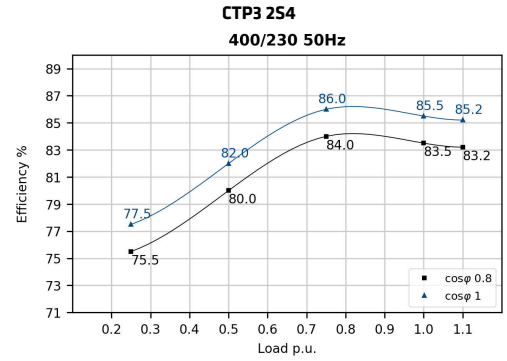
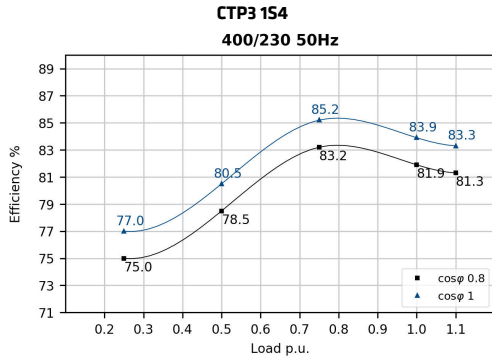

Efficiencies @ 60Hz

Models		415V 60Hz					440V 60Hz					460V 60Hz					480V 60Hz				
		0.25	0.5	0.75	1	1.1	0.25	0.5	0.75	1	1.1	0.25	0.5	0.75	1	1.1	0.25	0.5	0.75	1	1.1
CTP3 1S4	%	-	-	-	-	-	76,4	80,2	83,7	83,2	83,0	76,5	80,3	83,8	83,2	82,9	76,2	80,0	83,5	83,0	82,5
CTP3 2S4	%	-	-	-	-	-	76,9	81,6	85,7	85,2	85,0	76,9	81,6	85,8	85,3	84,8	76,8	81,5	85,5	85,0	84,3
CTP3 1L4	%	-	-	-	-	-	81,6	85,7	87,6	86,6	86,4	81,7	85,9	87,7	86,7	86,4	81,4	85,5	87,5	86,5	86,0
CTP3 2L4	%	-	-	-	-	-	82,7	86,6	88,1	87,1	86,8	82,9	86,7	88,2	87,2	86,6	82,5	86,5	88,0	87,0	86,5

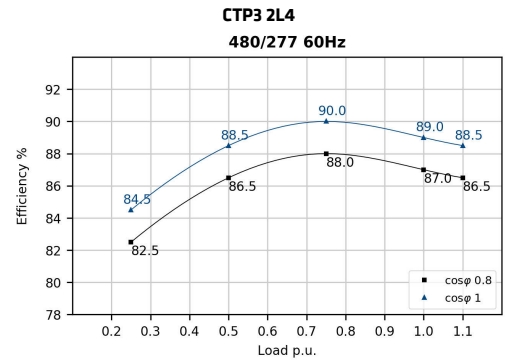
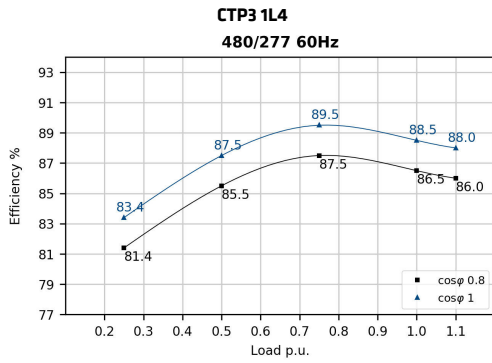
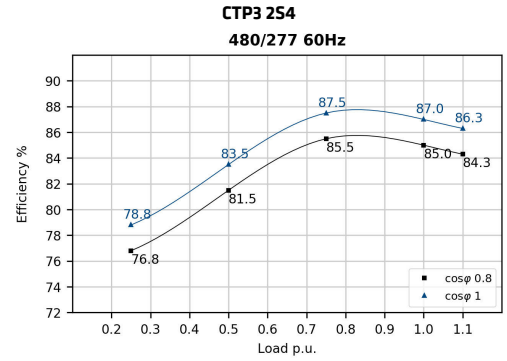
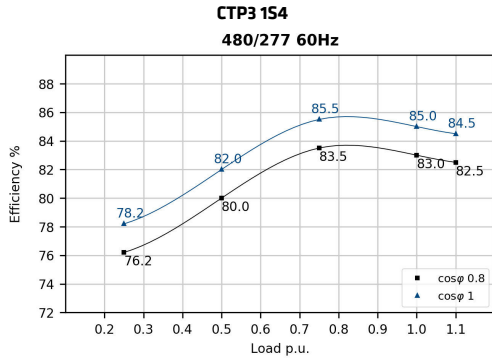

Transients voltage

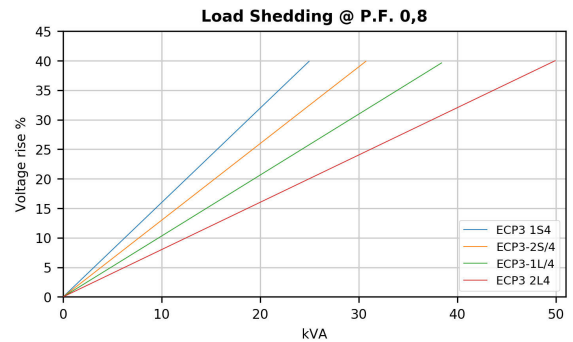
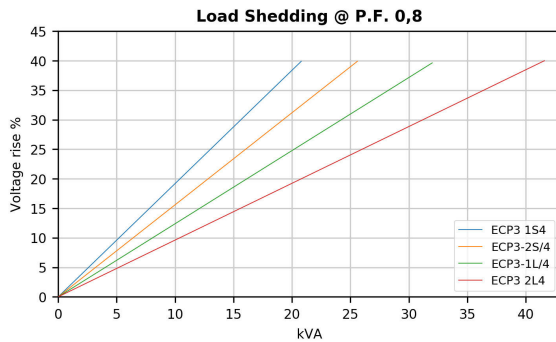
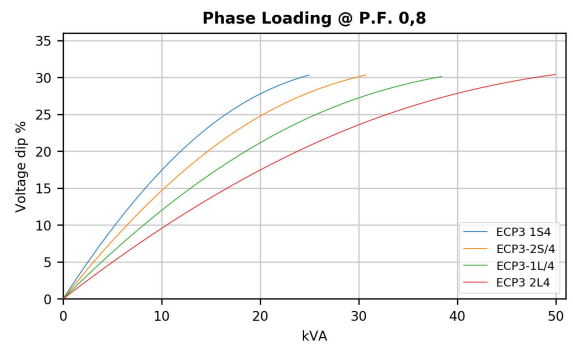
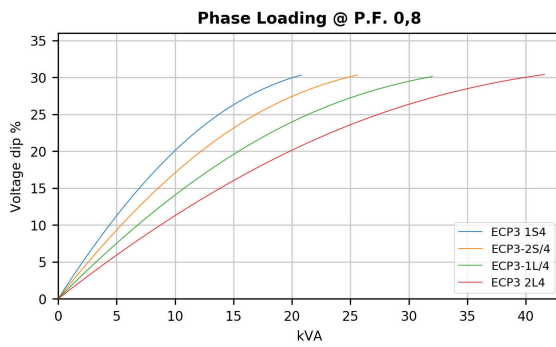
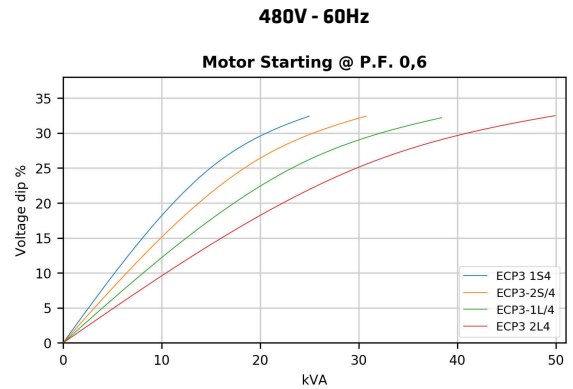
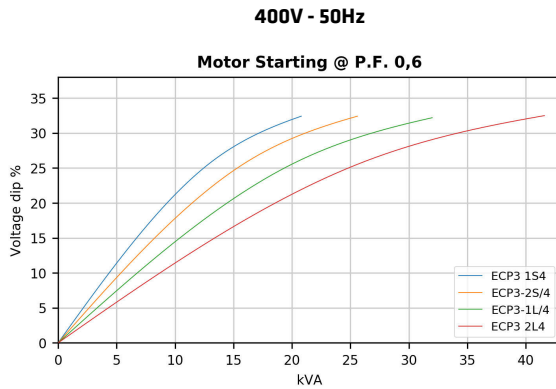

In order to scale transient curves as a function of a power factor or voltage if not indicated, please proceed as follows:

Power Factor coefficient corrector (PFCC), to be used on power factor 0.6 curves:

$$PFCC = \sin(\text{ARCCos}(PF_{\text{new}})) / 0.8$$

Example. The PFCC at power factor 0.3 is 1.192 [$PFCC = \sin(\text{ARCCos}(0.3)) / 0.8$]. This means that the voltage fall at a given power at pf 0.3 is equivalent to the one that can be read on the pf 0.6 curve if the load is considered 1.192 times bigger (19% higher value.).

In this example, a 100 kVA load insertion at pf 0.3 is equivalent in voltage fall to a 119kVA load insertion at pf 0.6.

Voltage coefficient corrector (VCC):

$$VCC = (400/V_{\text{new}})^2 \text{ if } 50 \text{ Hz}; VCC = (480/V_{\text{new}})^2 \text{ if } 60 \text{ Hz}$$

Example. VCC at 415V 60 Hz is 1.338 [$VCC = (480/415)^2$]. This means that the voltage fall at a given power at 415V is equivalent to the one that can be read on the power factor 0.6 curve if the load is considered 1.338 times bigger (33% higher value.).

In this example, a 100 kVA load insertion at 415V is equivalent in voltage fall to a 133kVA load insertion at 480V.

50Hz Short circuit decrement curves - No load excitation at rated speed

CTP3 1S4

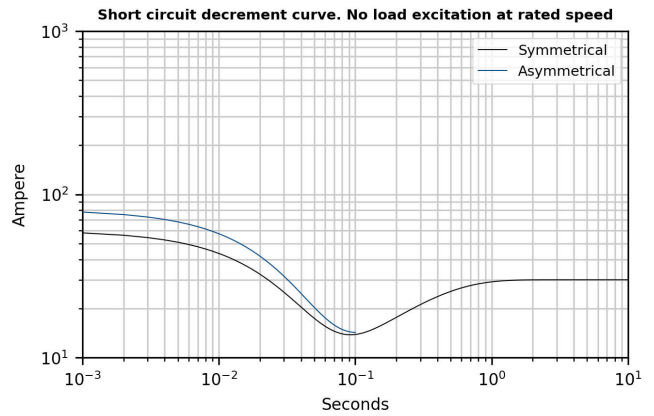

CTP3 2S4

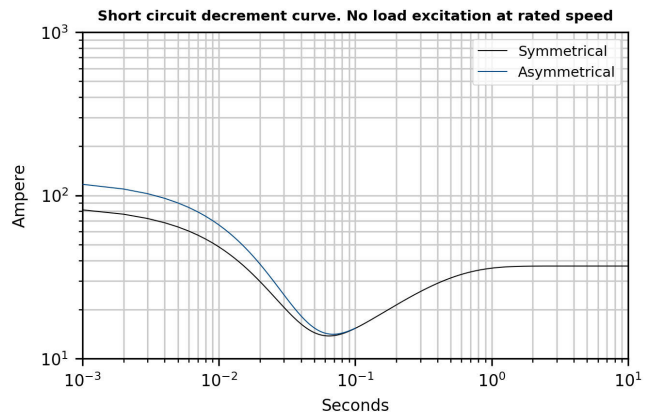

CTP3 1L4

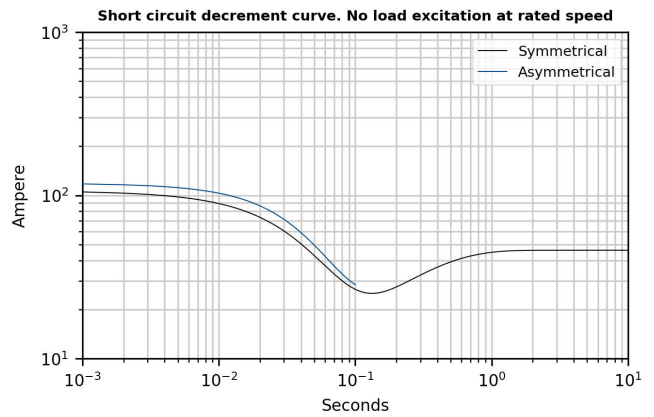

CTP3 2L4

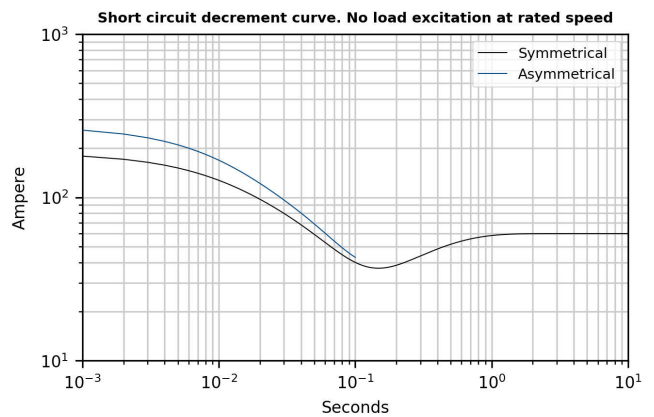

*Please refer to tables at page 6

60Hz Short circuit decrement curves - No load excitation at rated speed

CTP3 1S4

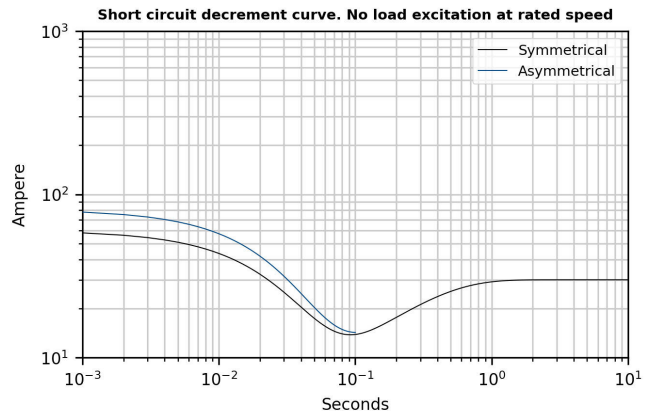

CTP3 2S4

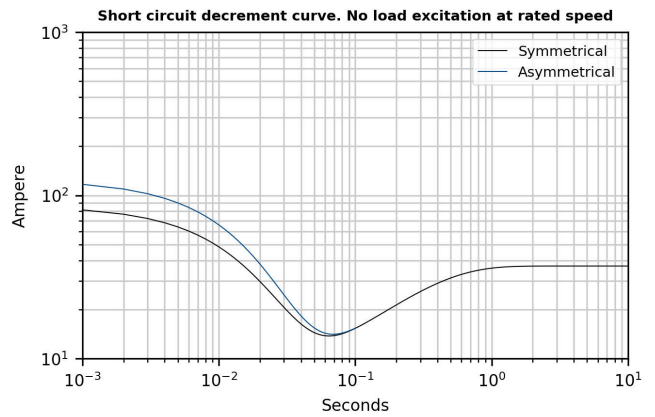

CTP3 1L4

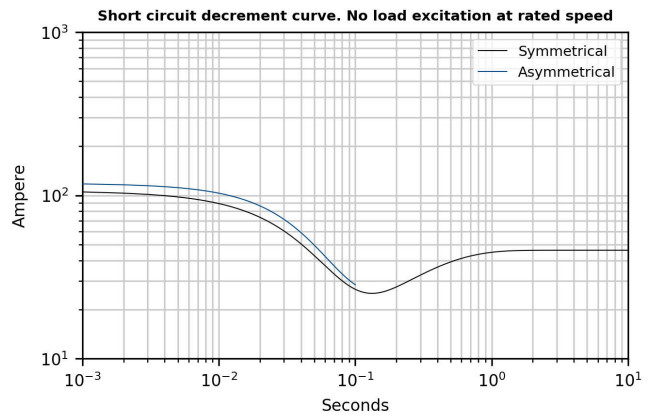

CTP3 2L4

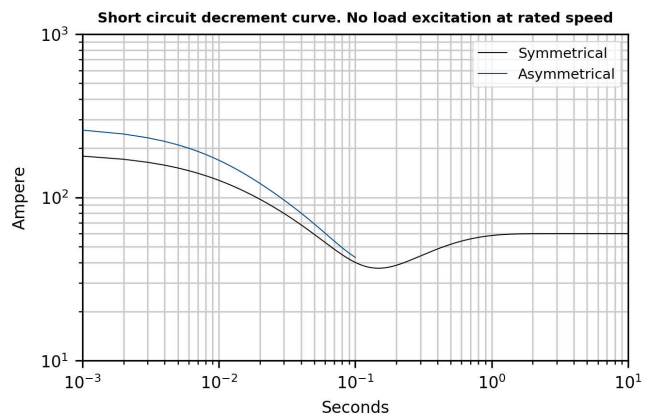

*Please refer to tables at page 6

Additional Characteristics

Data	CTP3 1S4		CTP3 2S4		CTP3 1L4		CTP3 2L4		
	50Hz	60Hz	50Hz	60Hz	50Hz	60Hz	50Hz	60Hz	
Damper cage	None								
Single stator coil resistance (20°C)	Ω	1,656		1,328		0,941		0,575	
Rotor Winding Resistance (20°C)	Ω	6,514		7,723		8,785		10,08	
Stator Exciter Resistance (20°C)	Ω	15,71		15,71		15,71		15,71	
Rotor Exciter Resistance (20°C)	Ω	1,453		1,453		1,453		1,453	
Auxiliary Winding Resistance (20°C)	Ω	-		-		-		-	
Weight of complete generator	kg	61,0		69,0		74,0		87,0	
Unbalanced magnetic pull	kN/mm	2,5		2,8		2,9		3,0	
Air flow	m ³ /min	3,5	3,9	3,5	4,1	3,3	4,0	3,0	3,5
Noise level at 1m/7m	dB(A)	72/58	78/60	72/58	78/60	72/58	78/60	72/58	78/60

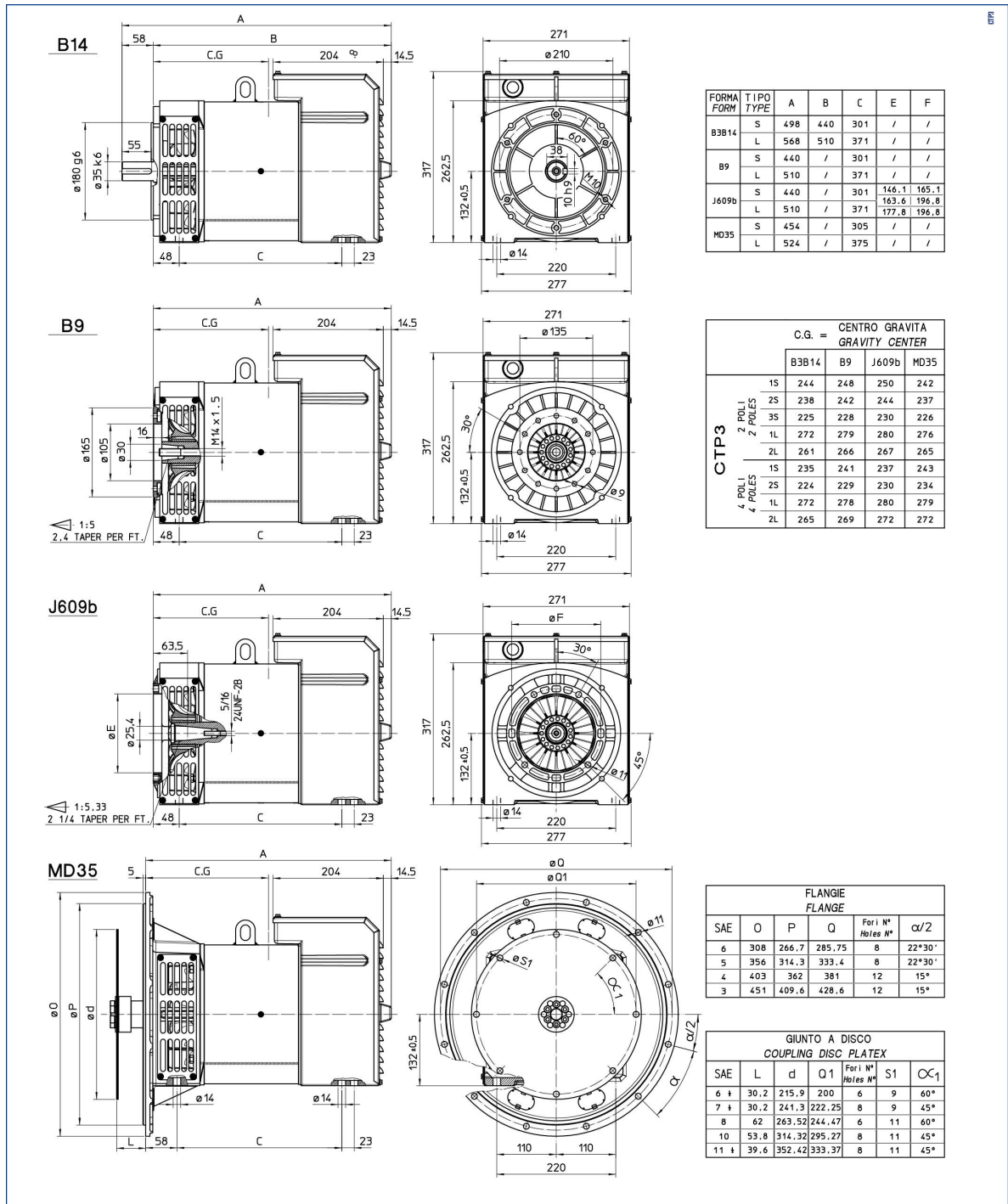

Mecc Alte SpA (HQ)

Via Roma
20 - 36051 Creazzo
Vicenza - ITALY
T: +39 0444 396111
E: info@meccalte.it
aftersales@meccalte.it

Mecc Alte Portable

Via Roma
20 - 36051 Creazzo
Vicenza - ITALY
T: +39 0444 396111
E: info@meccalte.it

Mecc Alte Power Products srl

Via Melaro
2 - 36075 Montecchio
Maggiore (VI) - ITALY
T: +39 0444 1831295
E: info@meccalte.it

Zanardi Alternatori srl

Via Dei Laghi
48/B - 36077 Altavilla
Vicenza - ITALY
T: +39 0444 370799
E: info@zanardialternatori.it

United Kingdom

Mecc Alte U.K. LTD
6 Lands' End Way
Oakham
Rutland LE15 6RF
T: +44 (0) 1572 771160
E: info@meccalte.co.uk

Spain

Mecc Alte España S.A.
C/ Rio Taibilla, 2
Polig. Ind. Los Valeros
03178 Benijofar (Alicante)
T: +34 (0) 96 6702152
E: info@meccalte.es

China

Mecc Alte Alternator Haimen LTD
755 Nanghai East Rd
Jiangsu HEDZ 226100 PRC
T: +86 (0) 513 82325758
E: info@meccalte.cn

India

Mecc Alte India PVT LTD
Plot NO: 1, Sanaswadi
Talegaon
Dhamdhare Road Taluka:
Shirur, District:
Pune - 412208
Maharashtra, India
T: +91 2137 619600
E: info@meccalte.in

U.S.A. and Canada

Mecc Alte Inc.
1229 Adams Drive
McHenry, IL, 60051
T: +1 815 344 0530
E: info@meccalte.us

Germany

Mecc Alte Generatoren GmbH
Bucher Hang 2
D-87448 Waltenhofen
T: +49 (0)831 540755 0
E: info@meccalte.de

Australia

Mecc Alte Alternators PTY LTD
10 Duncan Road, PO Box 1046
Dry Creek, 5094, South
Australia
T: +61 (0) 8 8349 8422
E: info@meccalte.com.au

France

Mecc Alte International S.A.
Z.E.La Gagnerie
16330 ST.Amant de Boixe
T: +33 (0) 545 397562
E: info@meccalte.fr

Far East

Mecc Alte (F.E.) PTE LTD
19 Kian Teck Drive
Singapore 628836
T: +65 62 657122
E: info@meccalte.com.sg



www.meccalte.com