



Totally Focused. Totally Independent.

Technical Specification

EC038 4 C



**The world's largest
independent producer of
alternators 1 – 5,000kVA**

All electrical / mechanical data are to be considered as a reference and they can be modified without any notice.

This document is a propriety of Mecc Alte S.p.A.. All rights reserved.

Standards

Alternators are designed and produced within an ISO 9001 environment. The entire series is manufactured according to, and complies with, the most common specifications such as CEI 2-3, IEC 34-1, EN 60034-1, VDE 0530, BS 4999-5000, NF 51.111, NEMA MG 1-2011, ISO 8528-3. They also comply with other specific standards such as UL1446, UL 1004/4 and /B and CAN/CSA-C22.2 No14-95-No100-95.

Windings and Performances

All windings are 2/3rds pitch to eliminate triplen harmonics within the voltage waveform and to avoid excessive neutral currents in certain parallel operating conditions. A fully interconnected aluminium or copper damper cage is supplied on the rotor of all models (excluding the ECP3 series).

- ▶ 12 wire reconnectable:
50Hz – 380V to 440V and 220/110V to 240/120V (de-rates may apply at certain voltages)
60Hz – 380V to 480V and 220/110V to 240/120V (de-rates may apply at certain voltages)
- ▶ 6 wire reconnectable:
50Hz – 380V to 440V and 220V to 240V (de-rates may apply at certain voltages)
60Hz – 380V to 480V and 220V to 240V (de-rates may apply at certain voltages)

Winding Configurations	Standard		Special (dedicated)			
	12 wire Reconnectable	6 wire Reconnectable	380V and 600V 60Hz	690V 50/60Hz	220-240V 1ph 50Hz	220-240V 1ph 60Hz
ECP3 to ECO38	Std	Option	Option	Option	Option	Option
ECO40 to ECO46	Std	Option	Option	Option	Option (to ECO40)	
ECO47	Std 4 wires		Option	Option		
Insulation materials	Class H	Class H	Class H	Class H	Class H	Class H
High efficiency	Std	Std	Std	Std	Std	Std
High motor starting	>300%	>300%	>300%	>300%	>300%	>300%
THD (Total Harmonic Distortion)	Typically <3.5% full load L-L	Typically <3.0% full load L-L	Typically <3.5% full load L-L	Typically <3.5% full load L-L	Typically <4.5% full load L-N	Typically <4.5% full load L-N
Interference suppression	VDE 0875 G/N/K, EN61000-6-3, EN61000-6-2, others available on request					

Winding Protection

There are various degrees of protection for the windings following the standard impregnation process, as can be seen here. The TOTAL+ butadienic black flexible coating is recommended for arduous applications.

Winding Protection:	STANDARD	STANDARD+	GREY	GREY+	TOTAL+
ECP3	Std	Option	Option	Option	Option
ECP28 and ECP32	-	Std	Option	Option	Option
NPE, ECP34 to ECO47	-	-	Std	Option	Option

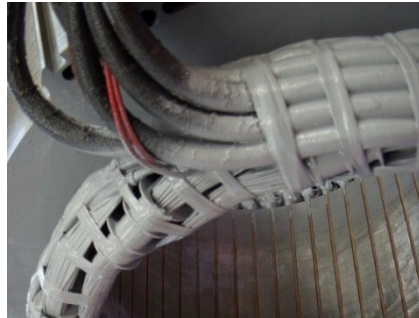

Grey treatment (marinization) on the left, TOTAL+ treatment shown on the right. The EG43 grey varnish, is an high temperature insulating enamel that forms a tough and flexible film, with excellent moisture and chemical protection. It is water and oil proof, and also protects windings from abrasion. It is applied spraying an over coating layer over the impregnated winding, or dipping the stator in a varnish barrel for superior treatments.

The TOTAL+ is a Mecc Alte protection system. It is the ultimate winding treatment that offers truly superior performances when the environment is really harsh, or the application very demanding. The TOTAL+ is also extremely resistant to the particle abrasion as it adsorbs the impacts.

Design

The robust mechanical structure withstands up to 5G in any direction and 9G vertically and its design permits easy access to the connections and components during routine maintenance check-ups. The mechanical design has used the most advanced FEM analysis. The materials used are: DD12 steel for the frame, C45 steel for the shaft and cast iron or aluminum pressure die cast for the end-brackets: fans are either aluminum die casted or nylon fiber glass loaded, UL compliant materials. Rotors are dynamically balanced according grades 6.3 (up to series 32) or 2.5 (from series 34 onwards) of ISO 1940-1.

Terminals and Terminal Box

Easy access to regulators is assured through a pull out drawer or a drop down panel to allow safer adjustment. Large terminal boxes allow easy access of power cables, in the ECO43 and ECO46 higher power ranges the terminal allow the convenient choice of power cable or busbar connection with versatility of entry and connection. Current transformers are available as an option on series ECO 40, 43, 46 and 47 with single or dual output.

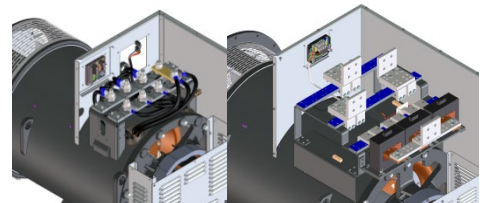

On C type family has been installed a new AVR panel. Terminal boards have been redesigned into a special L configuration, specifically to ease customer wiring; with this kind of terminal board it is possible to place a second terminal board in order to get 12 available terminals. Current transformers are available as an option on series ECO38 with single or dual output.

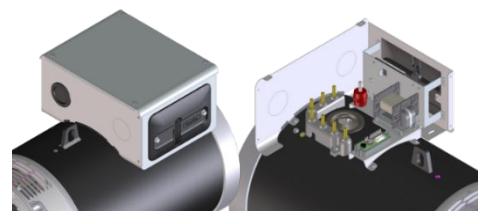

Ingress Protection

In addition to the protection on the windings themselves, alternators can increase the protection on the inlet side. Standard level is IP23 but the following solutions are also available: IP23 DP with inlet filters, IP23 with only terminal box in IP45, IP43 and IP45. Derates may be applied.

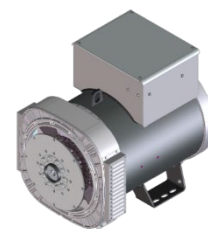

Info: https://www.meccalte.com/downloads/MA0605_Bulletin_IP.pdf

Excitation and Regulation Systems

All ECP/ECO series have MAUX auxiliary winding to power the digital regulator. Both DSR and the DER1 are available to connect to PC through the DxR2 USB interface and DxR TERMINAL software to interrogate/download alarms & settings for analysis or for cloning other regulators. DER2 has got an integrated USB connection and can be connected to the PC without any optional connection boards. More settings such as LAMS, digital RAM based synchronous external control and soft start are obtainable through the DxR connection. Simple analogue potentiometers are available for the more usual adjustments.

Excitation Systems	DSR	DER1	DER2
ECP3 to ECO38	Std	Option	Option
ECO40 to ECO46	-	Std	Option
ECO47	-	-	Std
Parallel Operation	√	√	√
Mains Parallel	√	√	√
3 Phase Sensing (rms)	-	√	√
Accuracy	+/-1%	+/-0.5%	+/-0.5%
Remote Voltage Control	√	√	√
Alarm Log	√	√	√
Analogue and Digital Configurable	√	√	√
LAMS (Load Acceptance V/f)	√	√	√
APO (Active Protection Output)	√	√	√
Soft Start	√	√	√
High dynamic response	-	-	√
USB connection without external boards	-	-	√

For a given motor start duty a smaller generator may be selected – as it has lower subtransient reactance values for non-linear loads. The whole range from 6.5 to 3400kVA is capable of >300% sustained short circuit current for up to 20 seconds.

Optional PMG

The Mecc Alte PMG is available on ECP28, ECP30, ECP32, ECP34 and ECO38 as factory-fitted option; alternatively, only the predisposition for the retrofit, for subsequent assembly, is available on option.

On ECO 40, 43 and 46 series it is available as a factory-fitted or retro-fitted options.

For ECO47 PMG is standard.

The complete AVR range is fully compatible with both MAUX and PMG systems, this minimises spare part management and flexibility of stock as one AVR suits all applications. The PMG is delivering the same amount of kVA available with the MAUX.

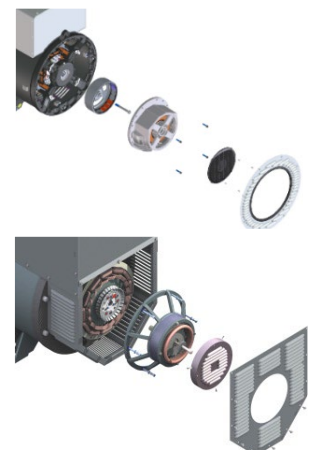

Dew Heater

Our entire range can be equipped with anti-condensation resistors of adequate power and sized for the alternator. Voltage for heaters must be specified when ordering. New cylindrical cartridge style heaters are available on request and it can be retrofitted.

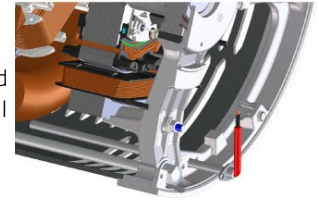

Accessories

Additional optionals can be fit on our alternator series, such as PTC thermistors or PT100 both on windings and bearings, dew heaters, high and low profile of terminal boxes (on most series), parallel devices, current and voltage transformers, air filters, IP43 and IP45 protections and many others.

For more info visit: <https://www.meccalte.com/en/products/alternators/accessories/c-type-accessories>

Deration coefficients

Altitude (meters)	Ambient temperature (Celsius)							
	25	40	45	50	55	60	65	70
≤ 1000	1.07	1	0.96	0.93	0.91	0.89	0.85	0.82
$> 1000 \leq 1500$	1.01	0.96	0.92	0.89	0.87	0.84	0.81	0.77
$> 1500 \leq 2000$	0.96	0.91	0.87	0.84	0.83	0.79	0.77	0.73
$> 2000 \leq 3000$	0.90	0.85	0.81	0.78	0.76	0.73	0.71	0.68
$> 3000 \leq 4000$	0.84	0.78	0.75	0.73	0.70	0.68	0.66	0.62
$> 4000 \leq 5000$	0.78	0.72	0.69	0.67	0.65	0.62	0.59	0.56
$> 5000 \leq 6000$	0.70	0.65	0.63	0.61	0.58	0.55	0.53	0.50

Notes on short circuit curves

The indicated coefficients have to be used to correct the three phase short circuit curves values as a function of the rated voltage.

The indicated coefficient have to be used to correct the three phase short circuit curves values as a function of the type of short circuit voltage.

50 Hz		60 Hz			3 phase	2 phase L-L	1 phase L-N
Voltage	Factor	Voltage	Factor				
380	0.93X	415	0.85X	<i>Istantaneous</i>	1X	0.87X	1.30X
400	1X	440	0.90X	<i>Minimum</i>	1X	1.80X	3.20X
415	1.04X	460	0.95X	<i>Sustained</i>	1X	1.50X	2.50X
440	1.10X	480	1X	<i>Max Duration</i>	20 sec.	10 sec.	4 sec.

All the curves are shown for series or parallel star connection at 400V 50 Hz or 480V 60 Hz. If the unit is reconnected from series to parallel star, the additional coefficient is 2X. From series star to series delta, it is 1.72X. From series star to parallel delta, it is 3.44X.

General characteristics

Pole number	4	Insulation class	H
Phase number	3	Protection class	IP23
Number of wires	12	NDE Bearing type	6314.2RS
Execution	Brushless	DE Bearing type	6318.2RS
Regulator type	DSR	Maximum Overspeed	2250
Winding pitch	2/3	Altitude	0-1000
Code voltage reference	T0405S3	Balancing	ISO1940-1

Ratings 50Hz

kVA / kW @ Temp. Rise / Ambient °C - 0.8 PF

	STANDBY-163/27				STANDBY-150/40				H-125/40				F-105/40				B-80/40			
Series	380V	400V	415V	440V	380V	400V	415V	440V	380V	400V	415V	440V	380V	400V	415V	440V	380V	400V	415V	440V
Parallel Star YY	190V	200V	208V	220V	190V	200V	208V	220V	190V	200V	208V	220V	190V	200V	208V	220V	190V	200V	208V	220V
Series Delta Δ	220V	230V	240V	254V	220V	230V	240V	254V	220V	230V	240V	254V	220V	230V	240V	254V	220V	230V	240V	254V
Parallel Delta ΔΔ	110V	115V	120V	127V	110V	115V	120V	127V	110V	115V	120V	127V	110V	115V	120V	127V	110V	115V	120V	127V
ECO38 154 C	kVA 196	196	196	180	188	188	188	173	180	180	180	165	170	170	170	155	144	144	144	132
	kW 157	157	157	144	150	150	150	138	144	144	144	132	136	136	136	124	115	115	115	106
ECO38 254 C	kVA 220	220	220	209	211	211	211	200	200	200	200	190	185	185	185	175	160	160	160	152
	kW 176	176	176	167	169	169	169	160	160	160	160	152	148	148	148	140	128	128	128	122
ECO38 1M4 C	kVA 250	250	250	234	237	237	237	221	225	225	225	210	207	207	207	190	180	180	180	168
	kW 200	200	200	187	190	190	190	177	180	180	180	168	166	166	166	152	144	144	144	134
ECO38 2M4 C	kVA 275	275	275	253	264	264	264	243	250	250	250	230	230	230	230	215	200	200	200	184
	kW 220	220	220	202	211	211	211	194	200	200	200	184	184	184	184	172	160	160	160	147
ECO38 1L4 C	kVA 330	330	330	319	315	315	315	305	300	300	300	290	275	275	275	265	240	240	240	232
	kW 264	264	264	255	252	252	252	244	240	240	240	232	220	220	220	212	192	192	192	186
ECO38 2L4 C	kVA 370	370	370	360	360	360	360	350	350	350	350	340	320	320	320	310	280	280	280	272
	kW 296	296	296	288	288	288	288	280	280	280	280	272	256	256	256	248	224	224	224	218
ECO38 VL4 C	kVA 380	400	400	370	370	380	380	360	360	370	370	350	329	338	338	319	288	296	296	280
	kW 304	320	320	296	296	304	304	288	288	296	296	280	263	270	270	255	230	237	237	224

Ratings 60Hz

kVA / kW @ Temp. Rise / Ambient °C - 0.8 PF

	STANDBY-163/27				STANDBY-150/40				H-125/40				F-105/40				B-80/40			
Series	415V	440V	460V	480V	415V	440V	460V	480V	415V	440V	460V	480V	415V	440V	460V	480V	415V	440V	460V	480V
Parallel Star YY	208V	220V	230V	240V	208V	220V	230V	240V	208V	220V	230V	240V	208V	220V	230V	240V	208V	220V	230V	240V
Series Delta Δ	240V	254V	265V	277V	240V	254V	265V	277V	240V	254V	265V	277V	240V	254V	265V	277V	240V	254V	265V	277V
Parallel Delta ΔΔ	120V	127V	133V	138V	120V	127V	133V	138V	120V	127V	133V	138V	120V	127V	133V	138V	120V	127V	133V	138V
ECO38 154 C	kVA 225	236	236	236	220	230	230	230	210	220	220	220	195	205	205	205	168	176	176	176
	kW 180	189	189	189	176	184	184	184	168	176	176	176	156	164	164	164	134	141	141	141
ECO38 254 C	kVA 253	264	264	264	242	253	253	253	230	240	240	240	210	220	220	220	184	192	192	192
	kW 202	211	211	211	194	202	202	202	184	192	192	192	168	176	176	176	147	154	154	154
ECO38 1M4 C	kVA 289	300	300	300	274	284	284	284	260	270	270	270	240	250	250	250	208	216	216	216
	kW 231	240	240	240	219	227	227	227	208	216	216	216	192	200	200	200	166	173	173	173
ECO38 2M4 C	kVA 319	330	330	330	305	316	316	316	290	300	300	300	270	280	280	280	232	240	240	240
	kW 255	264	264	264	244	253	253	253	232	240	240	240	216	224	224	224	186	192	192	192
ECO38 1L4 C	kVA 358	374	396	396	341	357	378	378	325	340	360	360	300	310	330	330	260	272	288	288
	kW 286	299	317	317	273	286	302	302	260	272	288	288	240	248	264	264	208	218	230	230
ECO38 2L4 C	kVA 402	444	444	444	391	438	438	438	380	420	420	420	350	385	385	385	304	336	336	336
	kW 322	355	355	355	313	350	350	350	304	336	336	336	280	308	308	308	243	269	269	269
ECO38 VL4 C	kVA 413	455	455	465	401	442	442	453	390	430	430	440	359	394	394	403	312	344	344	352
	kW 330	364	364	372	321	354	354	362	312	344	344	352	287	315	315	322	250	275	275	282

Reactance & Time constants- Class H / 400V

Unsaturated (ref. EN60034-4)			ECO38 1S4 C	ECO38 2S4 C	ECO38 1M4 C	ECO38 2M4 C	ECO38 1L4 C	ECO38 2L4 C	ECO38 VL4 C
X_d	Direct-axis synchronous reactance	%	203,9	207	198,7	214,2	215,3	222,5	226,3
X'_d	Direct-axis transient reactance	%	10	11,4	12,7	14,5	15,8	17,8	19,2
X''_d	Direct-axis subtransient reactance	%	5,69	6,11	6,72	7,45	8,38	9,73	10,8
X_q	Quadrature-axis synchronous reactance	%	100,3	113,8	109,7	121,1	124,2	130,4	135,6
X'_q	Quadrature-axis transient reactance	%	100,3	113,8	109,7	121,1	124,2	130,4	135,6
X''_q	Quadrature-axis subtransient reactance	%	20,4	22,2	23	22,8	21,5	20,8	20,1
X₂	Negative-sequence reactance	%	13,2	14,8	15,9	16,6	16,7	16,2	15,6
X₀	Zero sequence reactance	%	2,79	2,59	2,69	2,48	2,38	2,28	2,18
Saturated									
X_d	Direct-axis synchronous reactance	%	169,2	171,8	164,9	177,8	178,7	184,7	187,8
X'_d	Direct-axis transient reactance	%	8,33	9,45	10,5	12	13,1	14,8	15,9
X''_d	Direct-axis subtransient reactance	%	4,72	5,07	5,58	6,19	6,96	8,08	8,96
X_q	Quadrature-axis synchronous reactance	%	83,2	94,5	91	100,5	103,1	108,2	112,5
X'_q	Quadrature-axis transient reactance	%	83,2	94,5	91	100,5	103,1	108,2	112,5
X''_q	Quadrature-axis subtransient reactance	%	16,9	18,5	19,1	18,9	17,9	17,3	16,7
X₂	Negative-sequence reactance	%	11	12,3	13,2	13,7	13,8	13,5	12,9
X₀	Zero sequence reactance	%	2,79	2,59	2,69	2,48	2,38	2,28	2,18
K_{cc}	Short circuit ratio		0,44	0,46	0,45	0,44	0,43	0,42	0,53
T'_d	Transient time constant	sec	0,073	0,078	0,083	0,085	0,091	0,099	0,102
T''_d	Subtransient time constant	sec	0,011	0,012	0,013	0,013	0,012	0,013	0,012
T'_{do}	Open circuit time constant	sec	0,7	0,9	1,1	1,3	1,4	1,5	1,6
T_a	Armature time constant	sec	0,015	0,016	0,018	0,017	0,016	0,013	0,015

Additional information - Class H / 400V

I_o	Excitation current at no load	A	0,8	0,7	0,67	0,71	0,78	0,72	0,6
I_c	Excitation current at full load	A	3,2	3,0	3,0	2,8	3,9	3,9	3,1
Overload									
Overload per 20 sec. PRP or 10 sec. COP						%			
Heat dissipation						W			
Telephone Harmonic Factor - THF						%			
Waveform Distors.(THD) full load LL/LN						%			
Waveform Distors.(THD) no load LL/LN						%			

Reactance & Time constants- Class H / 480V

Unsaturated (ref. EN60034-4)			ECO38 1S4 C	ECO38 2S4 C	ECO38 1M4 C	ECO38 2M4 C	ECO38 1L4 C	ECO38 2L4 C	ECO38 VL4 C
X_d	Direct-axis synchronous reactance	%	207,7	207	198,7	214,2	215,3	222,5	224,3
X'_d	Direct-axis transient reactance	%	10,2	11,4	12,7	14,5	15,8	17,8	19
X''_d	Direct-axis subtransient reactance	%	5,8	6,11	6,72	7,45	8,38	9,73	10,7
X_q	Quadrature-axis synchronous reactance	%	102,1	113,8	109,7	121,1	124,2	130,4	134,4
X'_q	Quadrature-axis transient reactance	%	102,1	113,8	109,7	121,1	124,2	130,4	134,4
X''_q	Quadrature-axis subtransient reactance	%	20,8	22,2	23	22,8	21,5	20,8	19,9
X₂	Negative-sequence reactance	%	13,5	14,8	15,9	16,6	16,7	16,2	15,5
X₀	Zero sequence reactance	%	2,85	2,59	2,69	2,48	2,38	2,28	2,16
Saturated									
X_d	Direct-axis synchronous reactance	%	172,4	171,8	164,9	177,8	178,7	184,7	186,2
X'_d	Direct-axis transient reactance	%	8,49	9,45	10,5	12	13,1	14,8	15,8
X''_d	Direct-axis subtransient reactance	%	4,81	5,07	5,58	6,19	6,96	8,08	8,88
X_q	Quadrature-axis synchronous reactance	%	84,8	94,5	91	100,5	103,1	108,2	111,6
X'_q	Quadrature-axis transient reactance	%	84,8	94,5	91	100,5	103,1	108,2	111,6
X''_q	Quadrature-axis subtransient reactance	%	17,2	18,5	19,1	18,9	17,9	17,3	16,5
X₂	Negative-sequence reactance	%	11,2	12,3	13,2	13,7	13,8	13,5	12,9
X₀	Zero sequence reactance	%	2,85	2,59	2,69	2,48	2,38	2,28	2,16
K_{cc}	Short circuit ratio		0,44	0,46	0,45	0,44	0,43	0,42	0,54
T'_d	Transient time constant	sec	0,073	0,078	0,083	0,085	0,091	0,099	0,102
T''_d	Subtransient time constant	sec	0,011	0,012	0,013	0,013	0,012	0,013	0,012
T'_{do}	Open circuit time constant	sec	0,7	0,9	1,1	1,3	1,4	1,5	1,6
T_a	Armature time constant	sec	0,015	0,016	0,018	0,017	0,016	0,013	0,015

Additional information - Class H / 480V

I_o	Excitation current at no load	A	0,8	0,65	0,65	0,7	0,7	0,7	0,6
I_c	Excitation current at full load	A	3,2	2,9	2,9	2,8	3,8	3,9	3,1
Overload									
Overload per 20 sec. PRP or 10 sec. COP						%			
						300			
Heat dissipation		W	12437	12691	13299	13968	16118	20310	20881
Telephone Interference Factor - TIF			<40	<40	<40	<40	<40	<40	<40
Waveform Distors.(THD) full load LL/LN		%	3,1 / 3	3 / 2,9	2,8 / 2,9	2,9 / 3,1	3 / 2,9	3,1 / 2,9	3,2 / 3
Waveform Distors.(THD) no load LL/LN		%	2,8 / 2,7	2,7 / 2,6	2,6 / 2,8	2 / 2,1	2,6 / 2,8	2,7 / 2,7	2,8 / 2,6

Efficiencies @ 50Hz

Models		380V 50Hz					400V 50Hz					415V 50Hz					440V 50Hz				
		0.25	0.5	0.75	1	1.1	0.25	0.5	0.75	1	1.1	0.25	0.5	0.75	1	1.1	0.25	0.5	0.75	1	1.1
ECO38 1S4 C	%	89,1	91,2	92,3	92,3	92,1	88,9	91,3	92,6	92,4	92,1	88,7	91,3	92,5	92,1	91,8	88,5	91,1	92,2	91,9	91,5
ECO38 2S4 C	%	90,1	91,6	92,6	92,6	92,4	89,9	91,7	92,9	92,7	92,4	89,7	91,7	92,8	92,4	92,1	89,5	91,5	92,5	92,2	91,8
ECO38 1M4 C	%	89,6	91,9	93,0	92,9	92,7	89,4	92,0	93,3	93,0	92,7	89,2	92,0	93,2	92,7	92,4	89,0	91,8	92,9	92,5	92,1
ECO38 2M4 C	%	90,1	92,3	93,4	93,3	93,1	89,9	92,4	93,7	93,4	93,1	89,7	92,4	93,6	93,1	92,8	89,5	92,2	93,3	92,9	92,5
ECO38 1L4 C	%	90,2	92,7	93,8	93,5	93,3	89,9	92,7	94,0	93,7	93,4	89,7	92,7	93,9	93,4	93,1	89,5	92,5	93,6	93,2	92,8
ECO38 2L4 C	%	90,1	92,5	93,4	93,4	93,2	89,9	92,6	93,7	93,5	93,2	89,7	92,6	93,6	93,2	92,9	89,5	92,4	93,3	93,0	92,6
ECO38 VL4 C	%	90,3	92,4	93,5	93,5	93,3	90,1	92,5	93,8	93,6	93,3	89,9	92,5	93,7	93,3	93,0	89,7	92,3	93,4	93,1	92,8

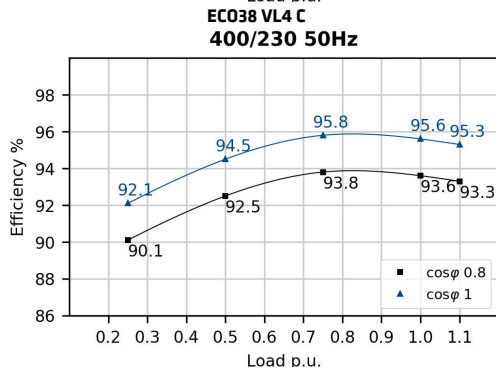
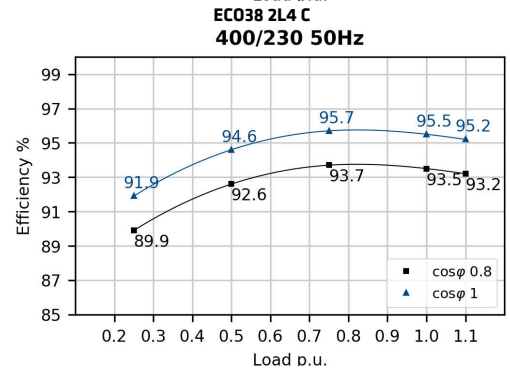
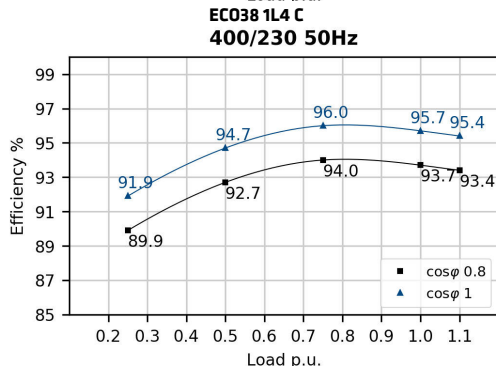
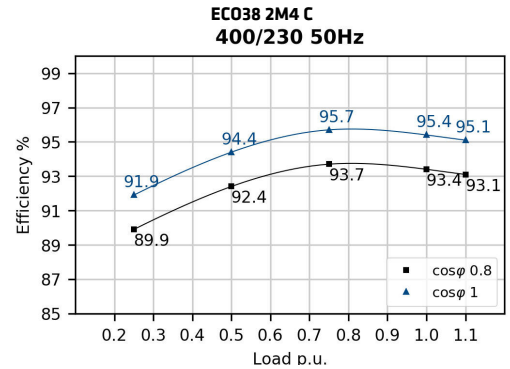
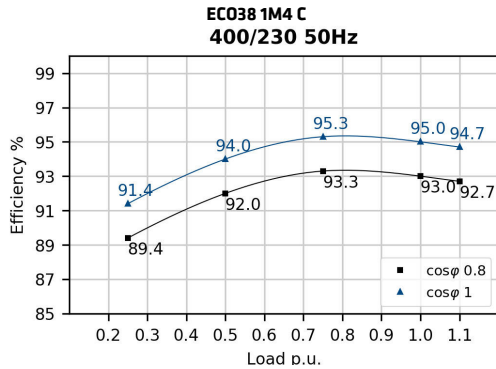
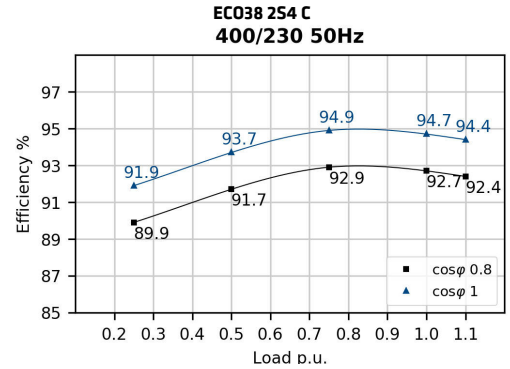
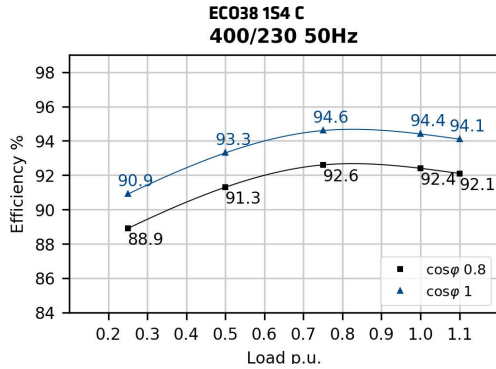

Efficiencies @ 60Hz

Models		415V 60Hz					440V 60Hz					460V 60Hz					480V 60Hz				
		0.25	0.5	0.75	1	1.1	0.25	0.5	0.75	1	1.1	0.25	0.5	0.75	1	1.1	0.25	0.5	0.75	1	1.1
ECO38 1S4 C	%	90,1	92,0	93,0	92,7	92,4	90,1	92,1	93,2	93,2	93,0	90,1	92,2	93,4	93,3	93,2	89,9	92,3	93,6	93,4	93,2
ECO38 2S4 C	%	90,6	92,5	93,4	93,1	92,8	90,6	92,6	93,6	93,6	93,4	90,6	92,7	93,8	93,7	93,6	90,4	92,8	94,0	93,8	93,6
ECO38 1M4 C	%	90,6	93,1	93,9	93,5	93,2	90,6	93,2	94,1	94,0	93,8	90,6	93,3	94,3	94,1	94,0	90,4	93,4	94,5	94,2	94,0
ECO38 2M4 C	%	90,6	93,4	94,3	93,8	93,5	90,6	93,5	94,5	94,3	94,1	90,6	93,6	94,7	94,4	94,2	90,4	93,7	94,9	94,5	94,1
ECO38 1L4 C	%	90,6	93,6	94,5	94,0	93,7	90,6	93,7	94,7	94,5	94,3	90,6	93,8	94,9	94,6	94,4	90,4	93,9	95,1	94,7	94,3
ECO38 2L4 C	%	90,6	93,0	93,9	93,6	93,3	90,6	93,1	94,1	94,1	93,9	90,6	93,2	94,3	94,2	94,0	90,4	93,3	94,5	94,3	93,9
ECO38 VL4 C	%	90,8	92,9	94,0	93,7	93,4	90,8	93,0	94,2	94,2	94,0	90,8	93,1	94,4	94,3	94,1	90,6	93,2	94,6	94,4	94,2

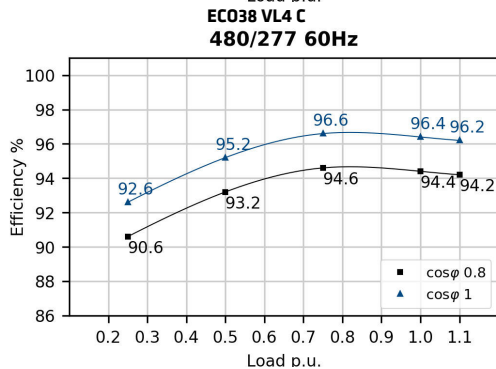
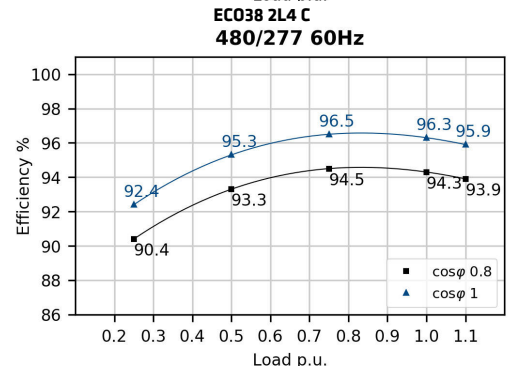
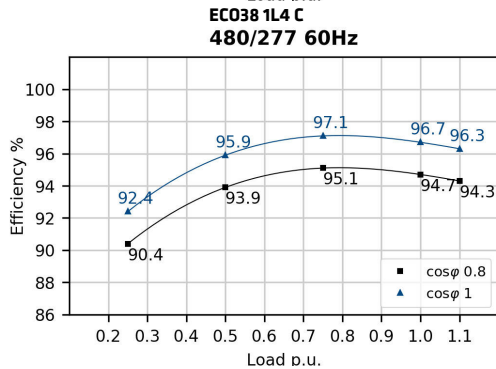
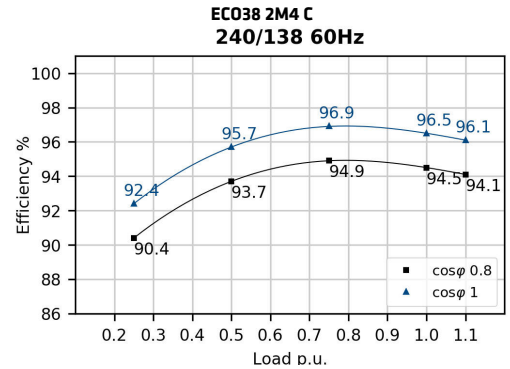
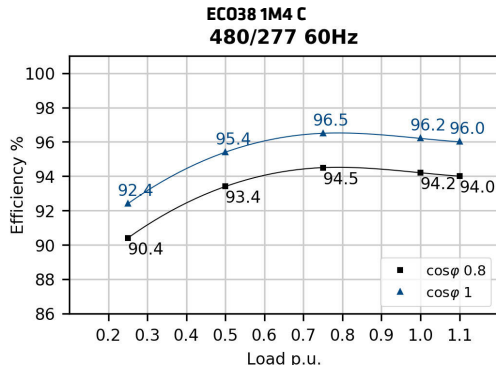
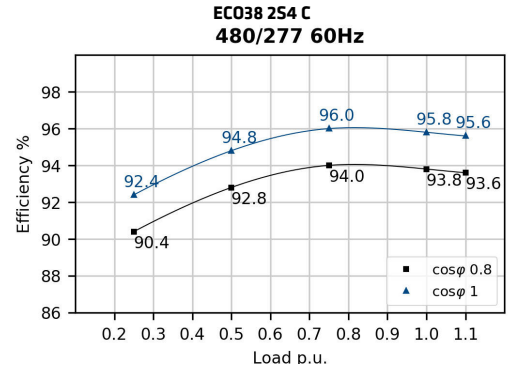
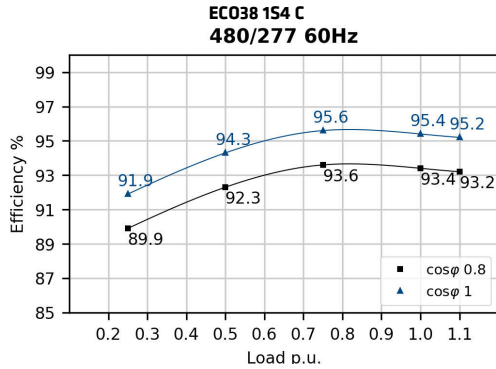

Transients voltage

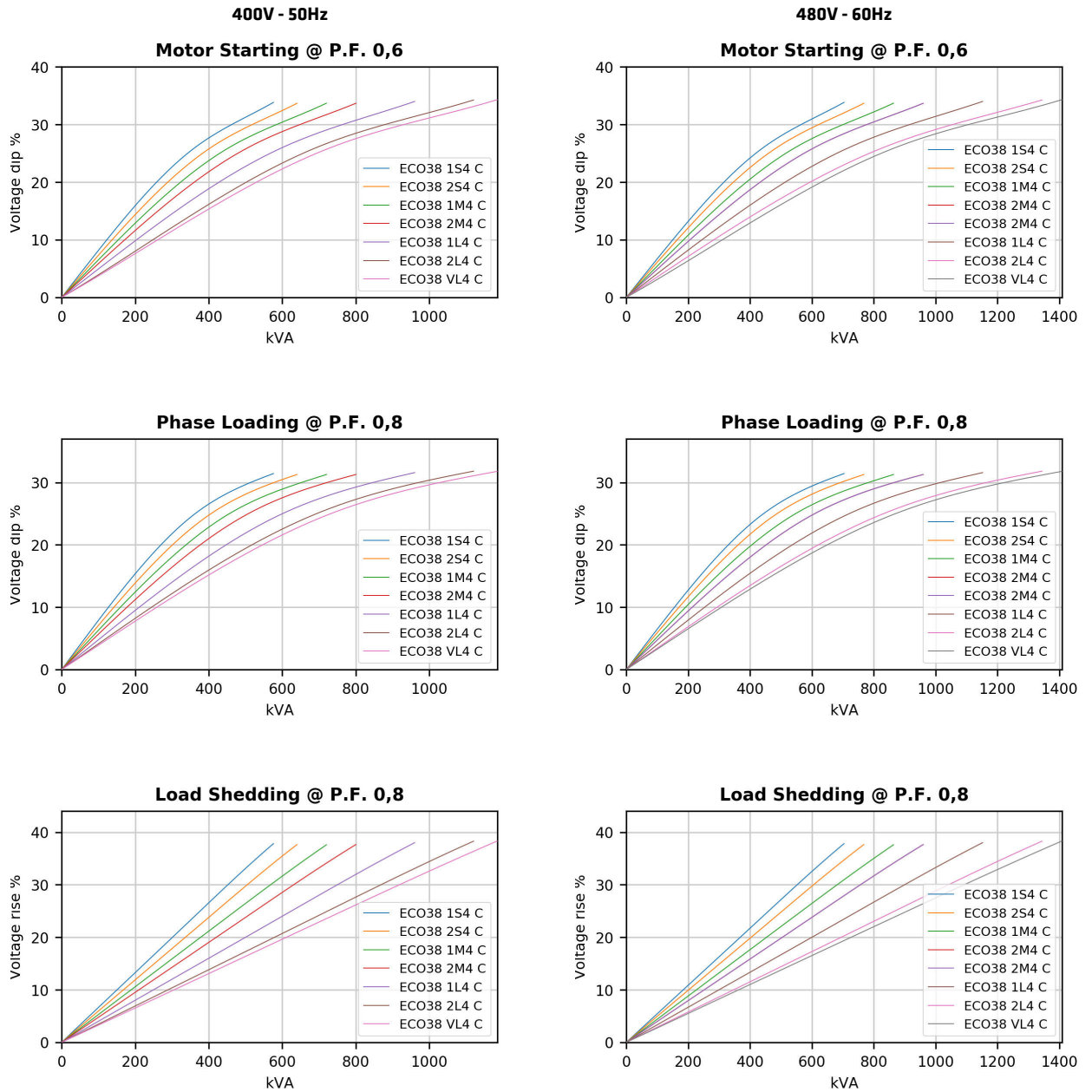

In order to scale transient curves as a function of a power factor or voltage if not indicated, please proceed as follows:

Power Factor coefficient corrector (PFCC), to be used on power factor 0.6 curves:

$$PFCC = \sin(\text{ARCCos}(PF_{\text{new}})) / 0.8$$

Example. The PFCC at power factor 0.3 is 1.192 [$PFCC = \sin(\text{ARCCos}(0.3)) / 0.8$]. This means that the voltage fall at a given power at pf 0.3 is equivalent to the one that can be read on the pf 0.6 curve if the load is considered 1.192 times bigger (19% higher value.).

In this example, a 100 kVA load insertion at pf 0.3 is equivalent in voltage fall to a 119kVA load insertion at pf 0.6.

Voltage coefficient corrector (VCC):

$$VCC = (400/V_{\text{new}})^2 \text{ if } 50 \text{ Hz}; VCC = (480/V_{\text{new}})^2 \text{ if } 60 \text{ Hz}$$

Example. VCC at 415V 60 Hz is 1.338 [$VCC = (480/415)^2$]. This means that the voltage fall at a given power at 415V is equivalent to the one that can be read on the power factor 0.6 curve if the load is considered 1.338 times bigger (33% higher value.).

In this example, a 100 kVA load insertion at 415V is equivalent in voltage fall to a 133kVA load insertion at 480V.

50Hz Short circuit decrement curves - No load excitation at rated speed

ECO38 1S4 C

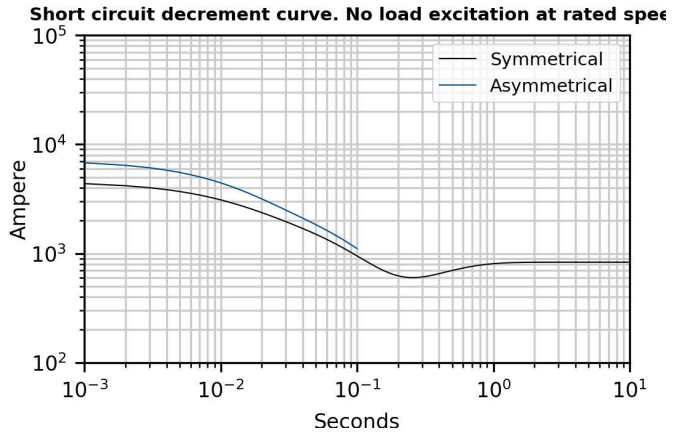

ECO38 2S4 C

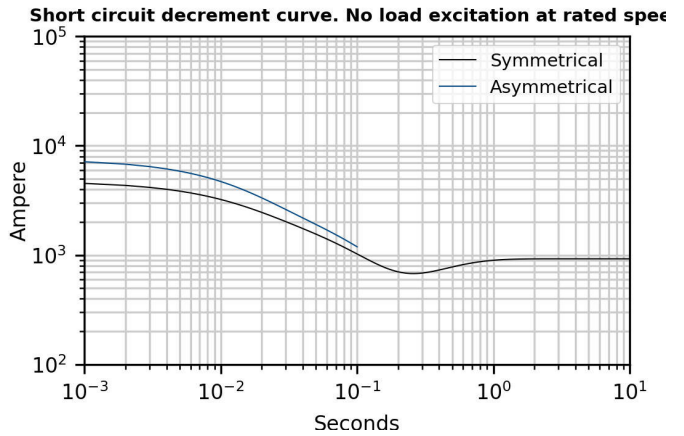

ECO38 1M4 C

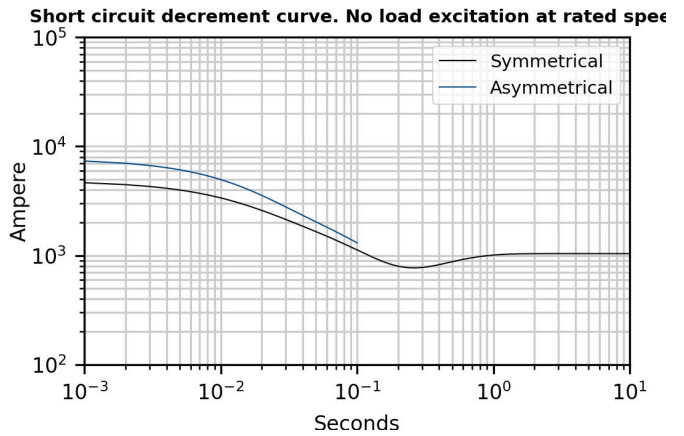

ECO38 2M4 C

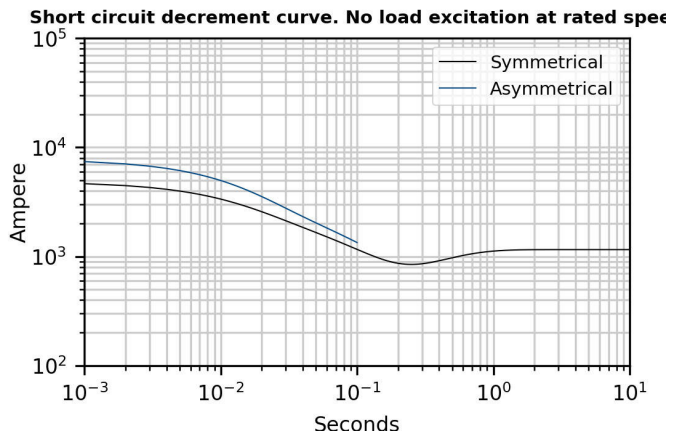

*Please refer to tables at page 6

50Hz Short circuit decrement curves - No load excitation at rated speed

ECO38 1L4 C

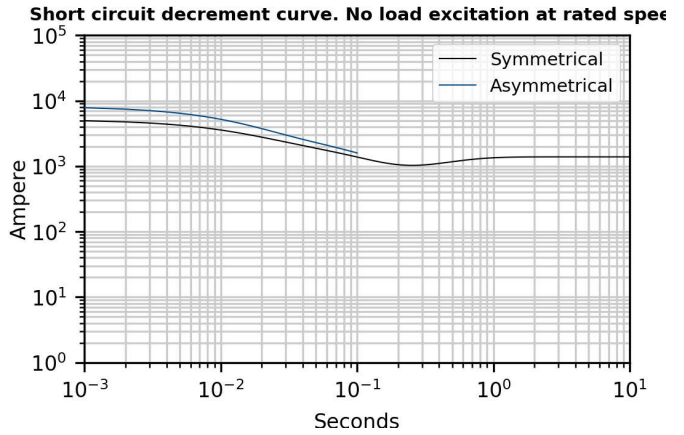

ECO38 2L4 C

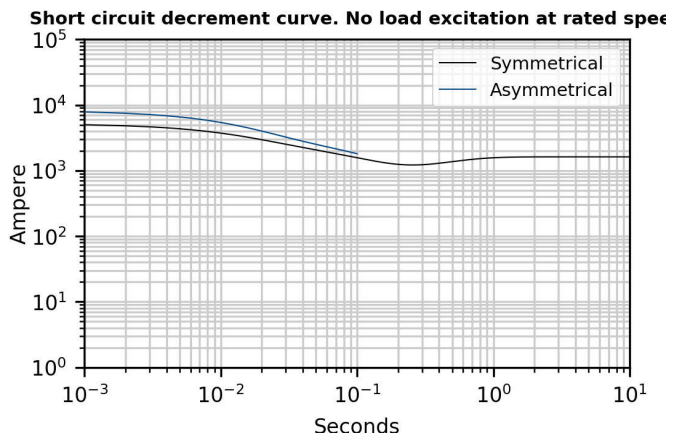

ECO38 VL4 C

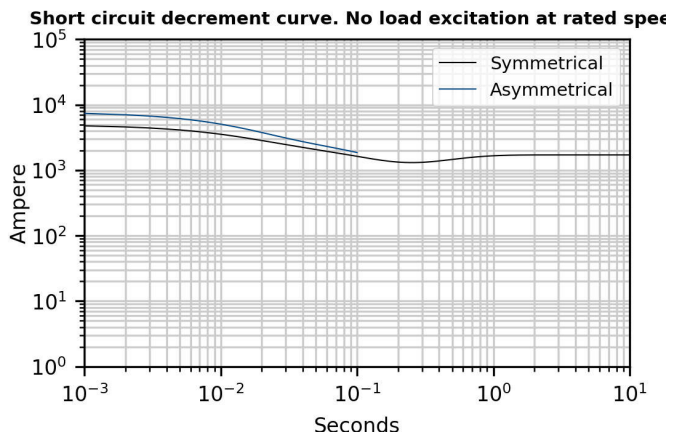

*Please refer to tables at page 6

60Hz Short circuit decrement curves - No load excitation at rated speed

ECO38 1S4 C

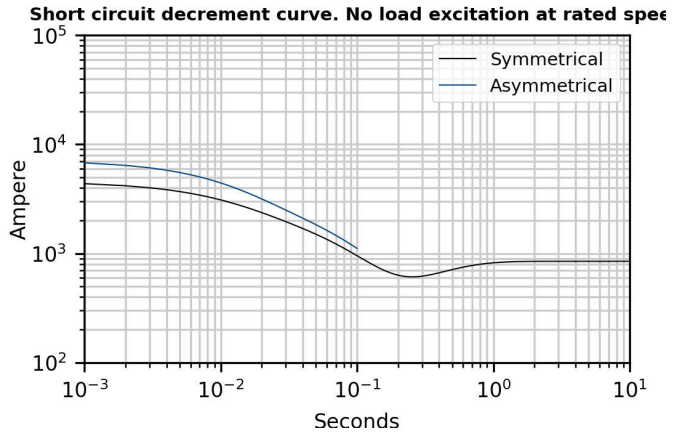

ECO38 2S4 C

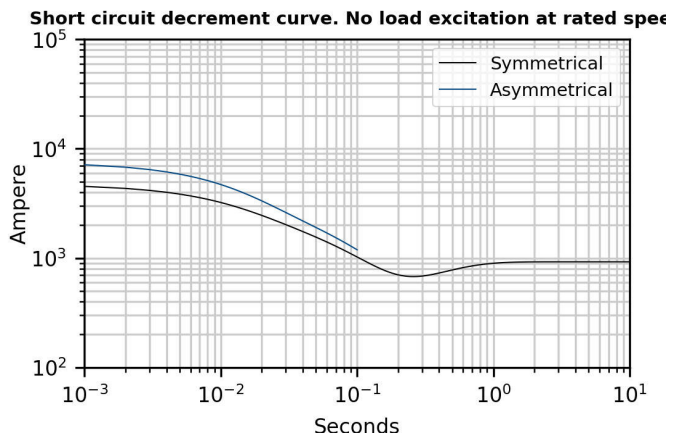

ECO38 1M4 C

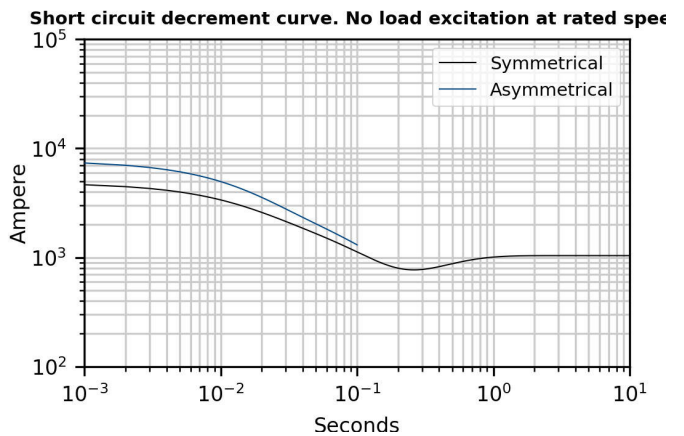

ECO38 2M4 C

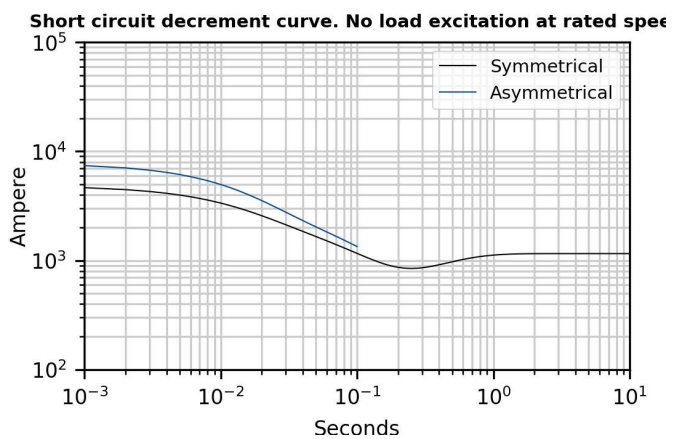

*Please refer to tables at page 6

60Hz Short circuit decrement curves - No load excitation at rated speed

ECO38 1L4 C

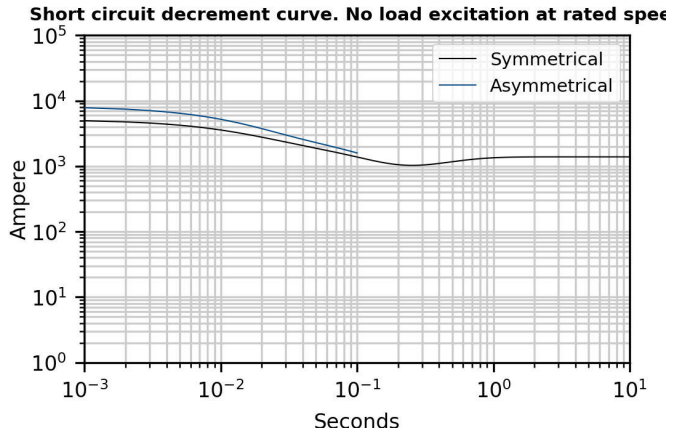

ECO38 2L4 C

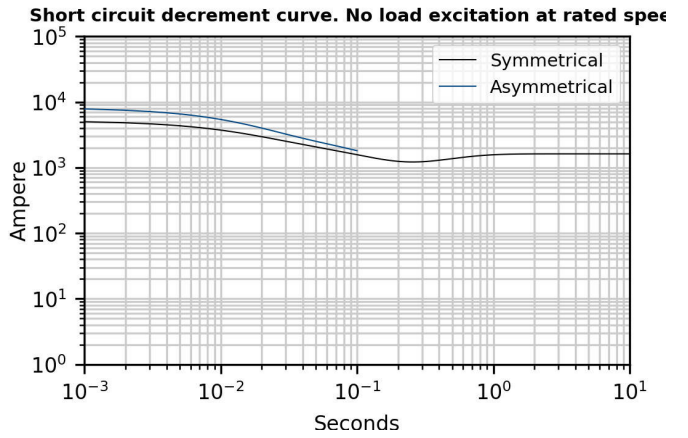

ECO38 VL4 C

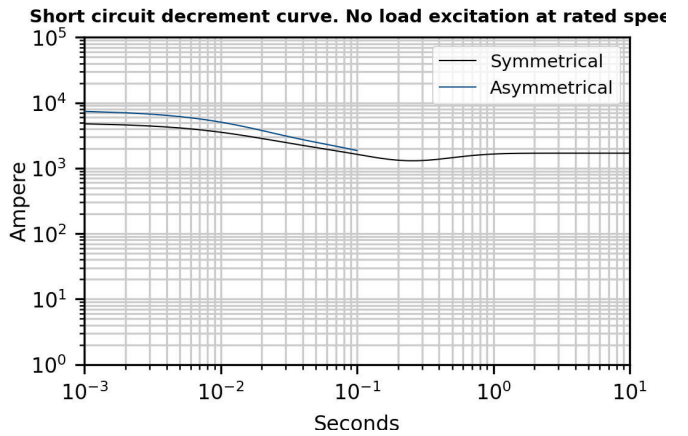

*Please refer to tables at page 6

Additional Characteristics

Data	ECO38 1S4 C		ECO38 2S4 C		ECO38 1M4 C		ECO38 2M4 C		ECO38 1L4 C		ECO38 2L4 C		ECO38 VL4 C		
	50Hz	60Hz	50Hz	60Hz	50Hz	60Hz	50Hz	60Hz	50Hz	60Hz	50Hz	60Hz	50Hz	60Hz	
Damper cage	Copper														
Stator Winding Resistance (20°C)	Ω	0,013		0,0105		0,008		0,0065		0,006		0,004		0,004	
Rotor Winding Resistance (20°C)	Ω	3,905		4,133		4,449		4,887		5,604		6,78		7,383	
Stator Exciter Resistance (20°C)	Ω	13,47		13,47		13,47		15,28		13,47		13,47		13,47	
Rotor Exciter Resistance (20°C)	Ω	0,719		0,719		0,719		0,719		0,719		0,719		0,719	
Auxiliary Winding Resistance (20°C)	Ω	0,854		0,845		0,778		0,796		0,751		0,7		0,7	
Weight of complete generator	kg	525,0		550,0		600,0		653,0		771,0		895,0		957,0	
Unbalanced magnetic pull	kN/mm	4,4		5,2		5,7		5,1		5,9		6,2		6,5	
Air flow	m ³ /min	32,0	39,0	32,0	39,0	32,0	39,0	32,0	39,0	32,0	39,0	32,0	39,0	32,0	39,0
Noise level at 1m/7m	dB(A)	82/69	86/73	82/69	86/73	82/69	86/73	82/69	86/73	82/69	86/73	82/69	86/73	82/69	86/73

PQ Diagram

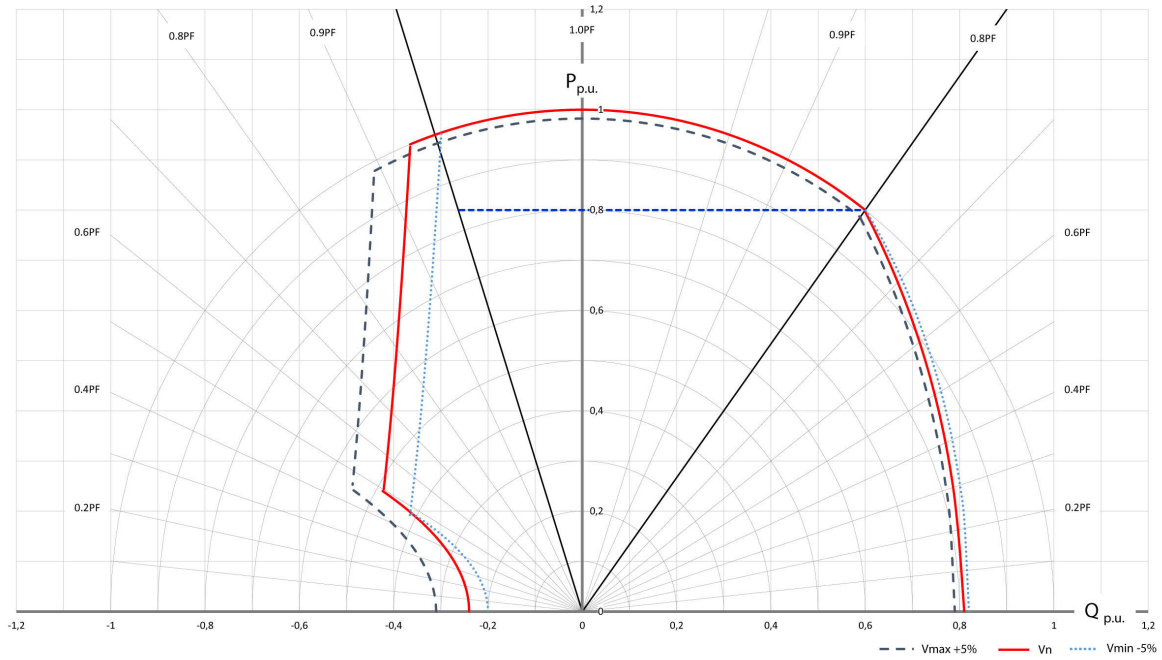

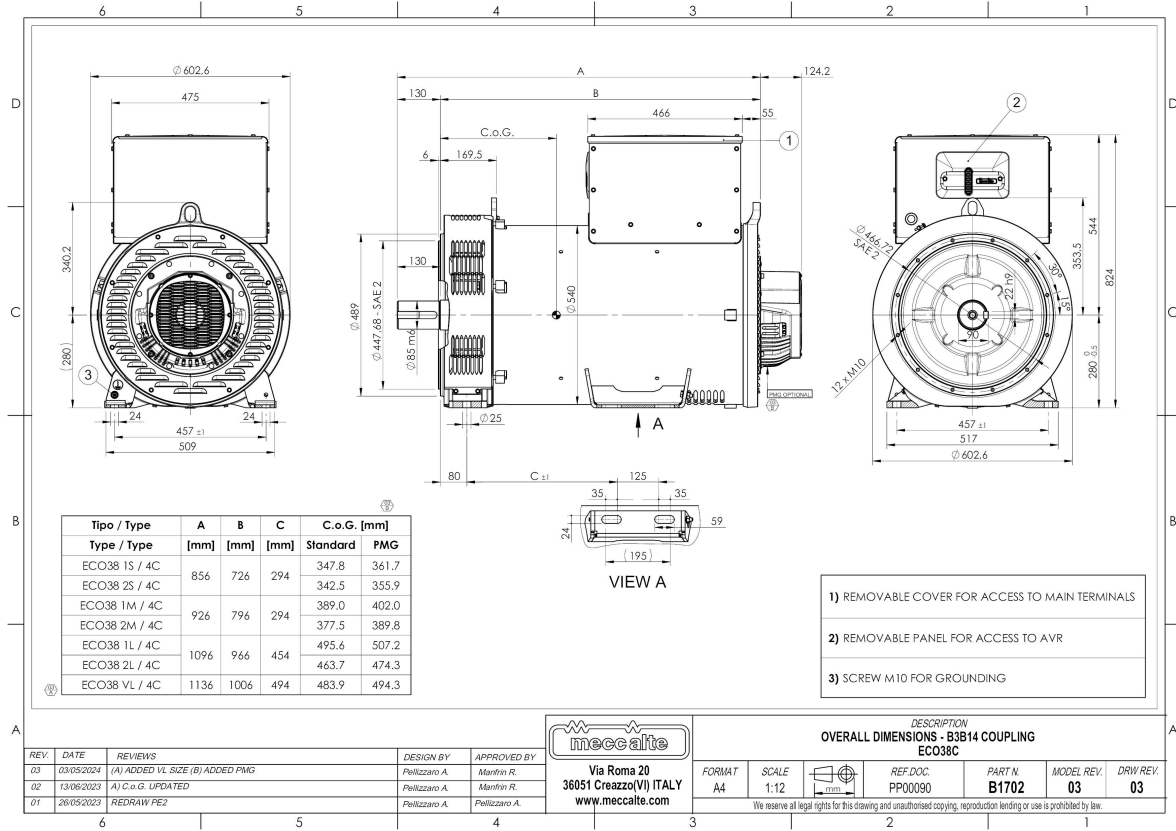
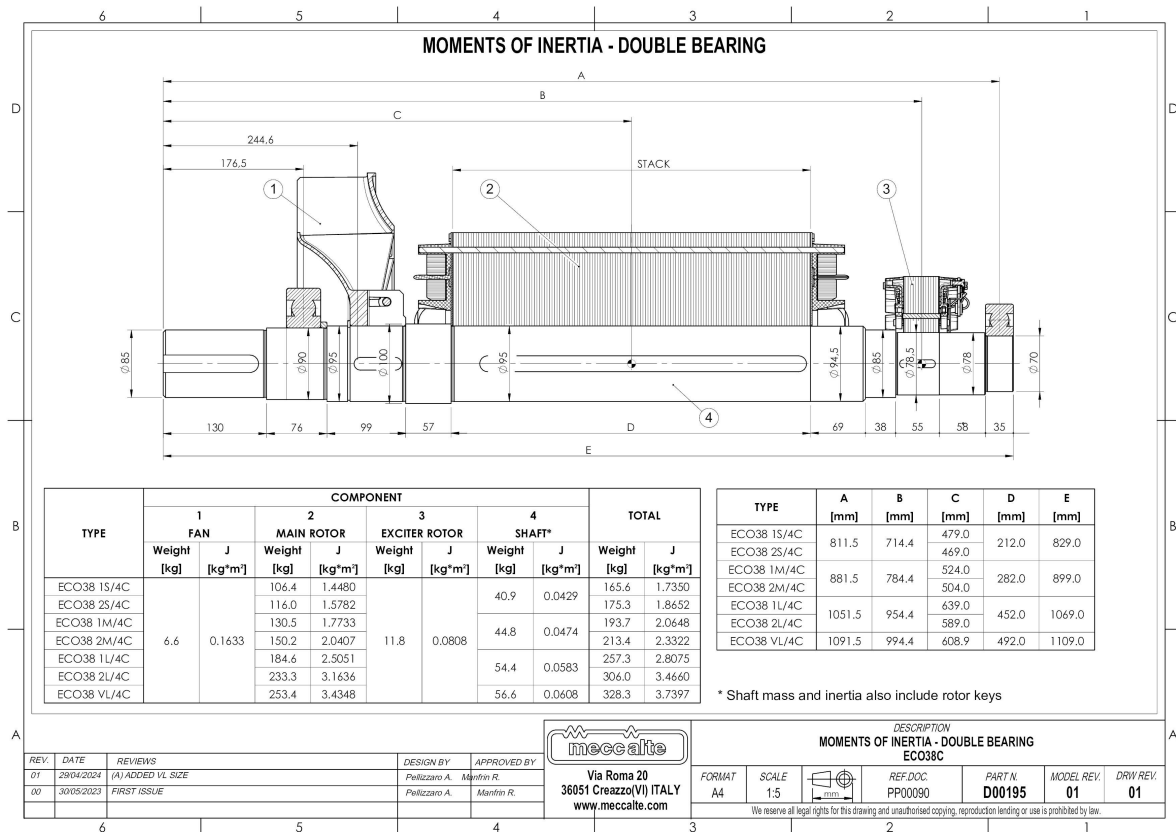

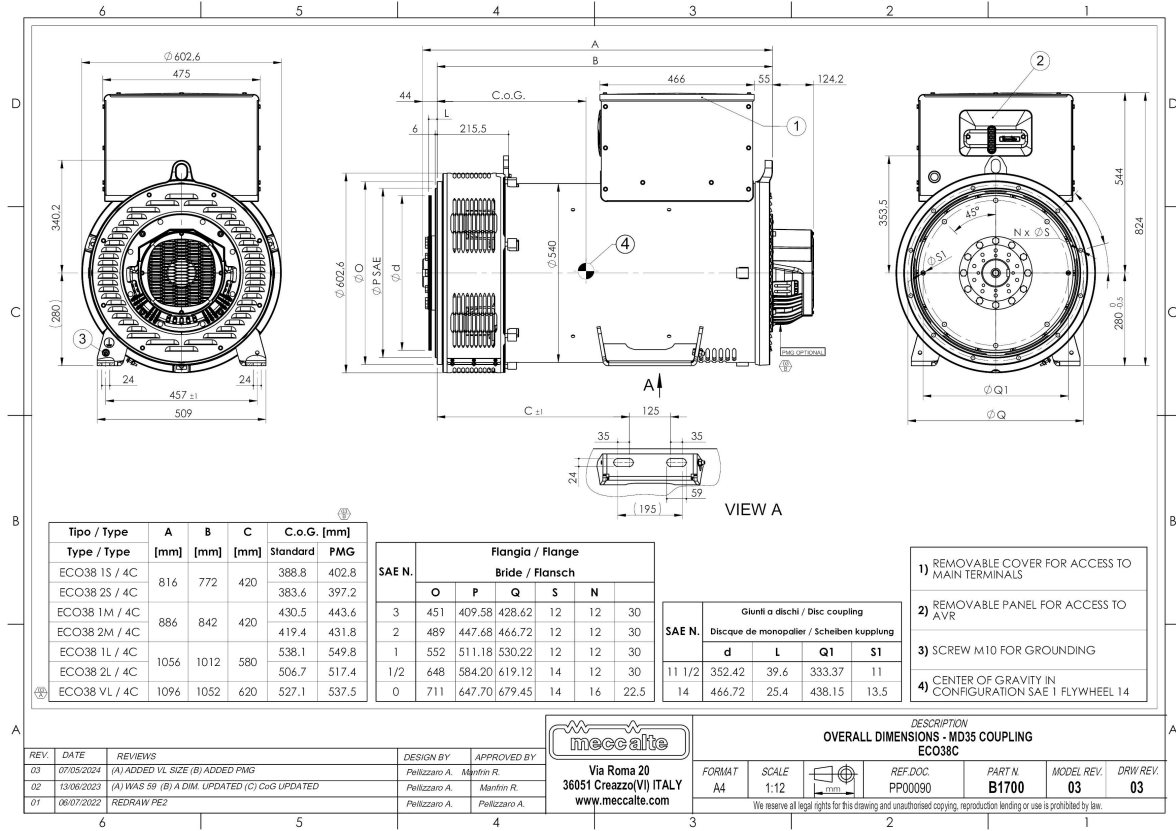
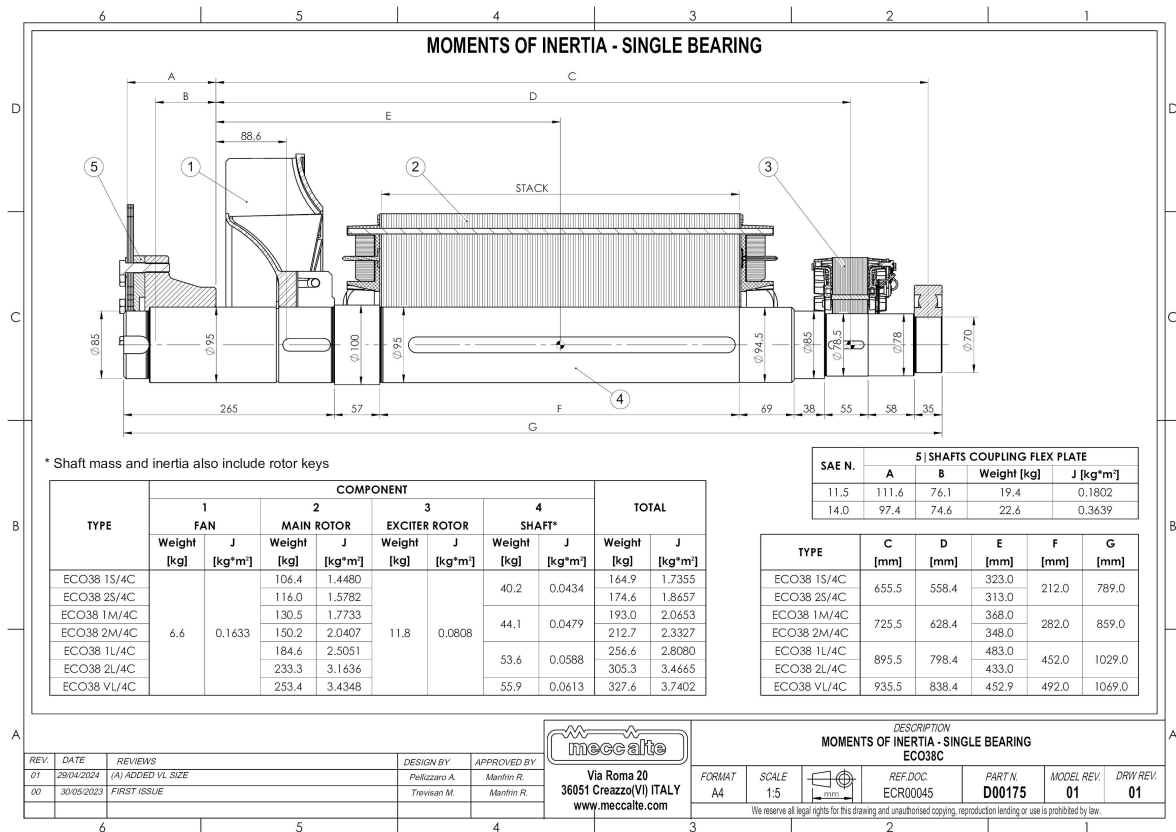

Mecc Alte SpA (HQ)

Via Roma
20 - 36051 Creazzo
Vicenza - ITALY
T: +39 0444 396111
E: info@meccalte.it
aftersales@meccalte.it

Mecc Alte Portable

Via Roma
20 - 36051 Creazzo
Vicenza - ITALY
T: +39 0444 396111
E: info@meccalte.it

Mecc Alte Power Products srl

Via Melaro
2 - 36075 Montecchio
Maggiore (VI) - ITALY
T: +39 0444 1831295
E: info@meccalte.it

Zanardi Alternatori srl

Via Dei Laghi
48/B - 36077 Altavilla
Vicenza - ITALY
T: +39 0444 370799
E: info@zanardialternatori.it

United Kingdom

Mecc Alte U.K. LTD
6 Lands' End Way
Oakham
Rutland LE15 6RF
T: +44 (0) 1572 771160
E: info@meccalte.co.uk

Spain

Mecc Alte España S.A.
C/ Rio Taibilla, 2
Polig. Ind. Los Valeros
03178 Benijofar (Alicante)
T: +34 (0) 96 6702152
E: info@meccalte.es

China

Mecc Alte Alternator Haimen LTD
755 Nanghai East Rd
Jiangsu HEDZ 226100 PRC
T: +86 (0) 513 82325758
E: info@meccalte.cn

India

Mecc Alte India PVT LTD
Plot NO: 1, Sanaswadi
Talegaon
Dhamdhare Road Taluka:
Shirur, District:
Pune - 412208
Maharashtra, India
T: +91 2137 619600
E: info@meccalte.in

U.S.A. and Canada

Mecc Alte Inc.
1229 Adams Drive
McHenry, IL, 60051
T: +1 815 344 0530
E: info@meccalte.us

Germany

Mecc Alte Generatoren GmbH
Bucher Hang 2
D-87448 Waltenhofen
T: +49 (0)831 540755 0
E: info@meccalte.de

Australia

Mecc Alte Alternators PTY LTD
10 Duncan Road, PO Box 1046
Dry Creek, 5094, South
Australia
T: +61 (0) 8 8349 8422
E: info@meccalte.com.au

France

Mecc Alte International S.A.
Z.E.La Gagnerie
16330 ST.Amant de Boixe
T: +33 (0) 545 397562
E: info@meccalte.fr

Far East

Mecc Alte (F.E.) PTE LTD
19 Kian Teck Drive
Singapore 628836
T: +65 62 657122
E: info@meccalte.com.sg



www.meccalte.com