

S16W

MECCALTE spa - Via Roma, 20 - 36051 CREAZZO (VI) ITALY
Tel. +39 0444/396111 - Fax +39 0444/396166 - e-mail: info@meccalte.it
website: www.meccalte.com

2 POLE
1 PHASE
IP23

CHARACTERISTICS

50 Hz

Type	115/230V 50Hz 3000 RPM									
	kVA	η	η	η	T.H.D.	Air volume	Noise		Weight	J
		2/4 1 p.f.	3/4 1 p.f.	4/4 1 p.f.			7m dBA	1m dBA		
CL. H	%	%	%	%	m ³ /min			Kg	Kgm ²	
S16W - 75	2,5	71	74,2	74	< 6	2,5	56	72	14,3	0,0057
S16W - 90	3,5	72	75,2	75	< 6	2,5	56	72	16,1	0,0068
S16W - 105	4,1	73,1	76,1	76	< 6	2,4	56	72	17,7	0,0074
S16W - 130	5	74,1	77,2	77	< 6	2,4	56	72	21	0,0084
S16W - 150	5,7	75	78,1	78	< 6	2,3	56	72	23,7	0,0098

60 Hz

Type	120/240V 60Hz 3600 RPM									
	kVA	η	η	η	T.H.D.	Air volume	Noise		Weight	J
		2/4 1 p.f.	3/4 1 p.f.	4/4 1 p.f.			7m dBA	1m dBA		
CL. H	%	%	%	%	m ³ /min			Kg	Kgm ²	
S16W - 75	3	71,5	74,7	74,6	< 6	3,3	60	77	14,3	0,0057
S16W - 90	4,2	72,7	75,8	75,6	< 6	3,3	60	77	16,1	0,0068
S16W - 105	5	73,8	76,8	76,6	< 6	3,2	60	77	17,7	0,0074
S16W - 130	6	74,6	77,7	77,6	< 6	3,2	60	77	21	0,0084
S16W - 150	6,8	75,7	78,8	78,6	< 6	3,1	60	77	23,7	0,0098

OVERALL DIMENSIONS



dimensions in mm.

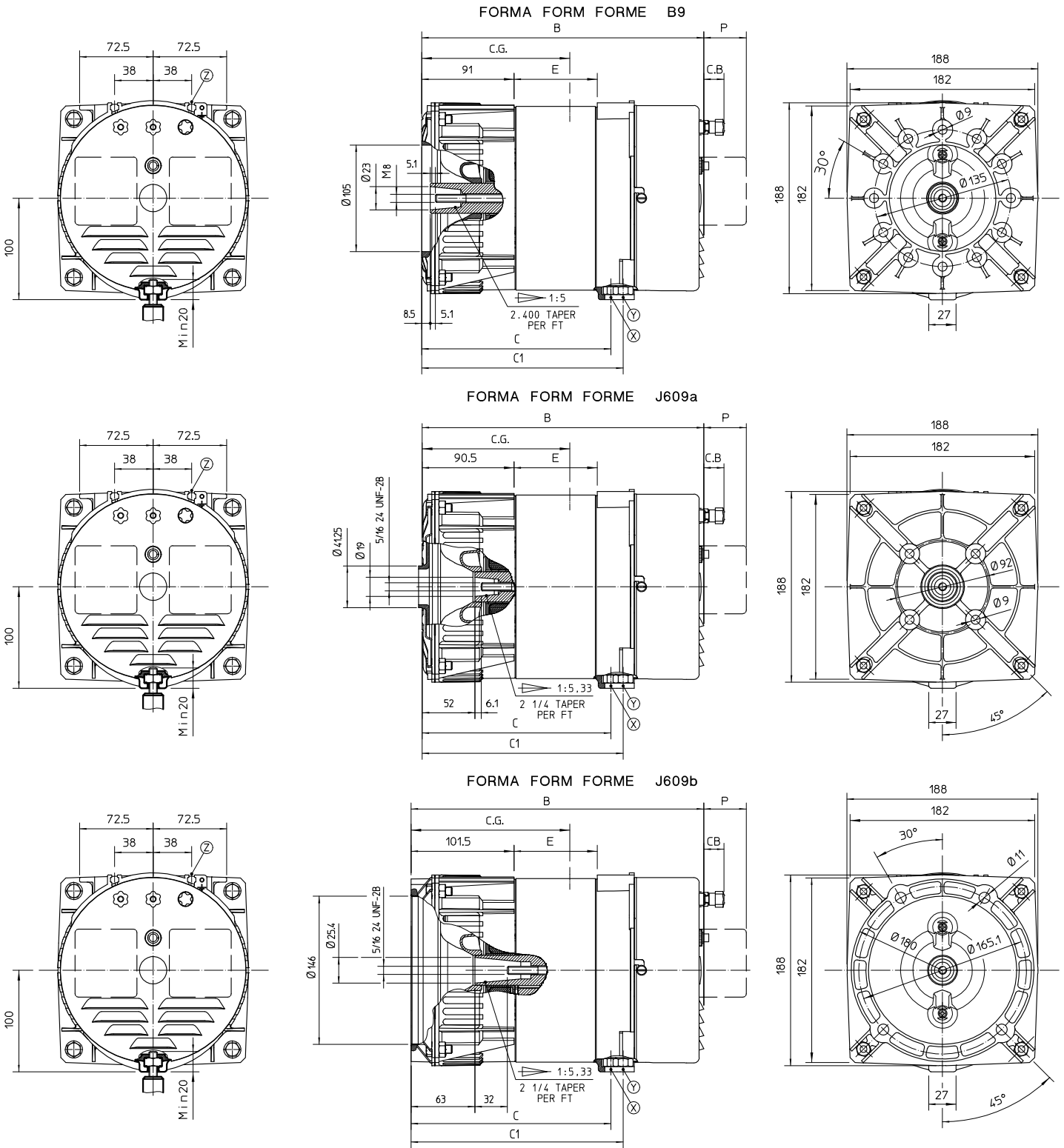

FORM	TYPE	B	C	C1	D	E	B	CG
							WITH SHORTER END COVER WITHOUT SOCKETS	
B9	S16W-75	279	186	198	147,5	82	249	140
	S16W-90	294	201	213	162,5	97	264	146
	S16W-105	309	216	228	177,5	112	279	150
	S16W-130	334	241	253	202,5	137	304	162
J609a	S16W-150	354	261	273	222,5	157	324	177
	S16W-75	278,5	185,5	197,5	147,5	82	248,5	139
	S16W-90	293,5	200,5	212,5	162,5	97	263,5	145
	S16W-105	308,5	216	228	177,5	112	278,5	149
J609b	S16W-75	289,5	197	209	147,5	82	259,5	147
	S16W-90	304,5	212	224	162,5	97	274,5	153
	S16W-105	319,5	227	239	177,5	112	289,5	157
	S16W-130	344,5	252	264	202,5	137	314,5	169
	S16W-150	364,5	272	284	222,5	157	334,5	184

SOCKETS TYPE	P	WITH BATTERY CHARGING OPTIONAL	X
AMERICAN	0		
FRENCH	6	20	Y DADO-NUT-ECROU-MUTTER-TUERCA UNI 5588-M10 25Nm
SCHUKO	9		
CEE	46,5		

OVERALL DIMENSIONS B3B14 KIT



dimensions in mm.

SHAFT DIAMETER 22,2mm

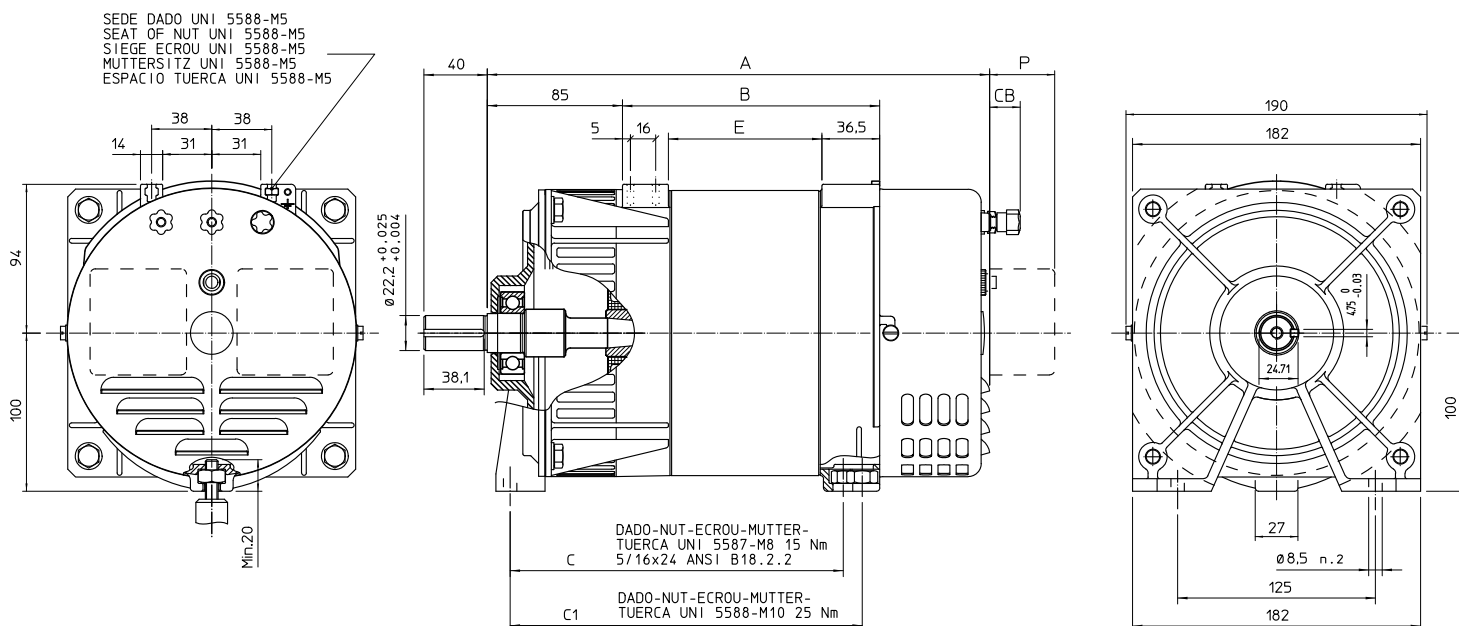

SHAFT DIAMETER 24mm

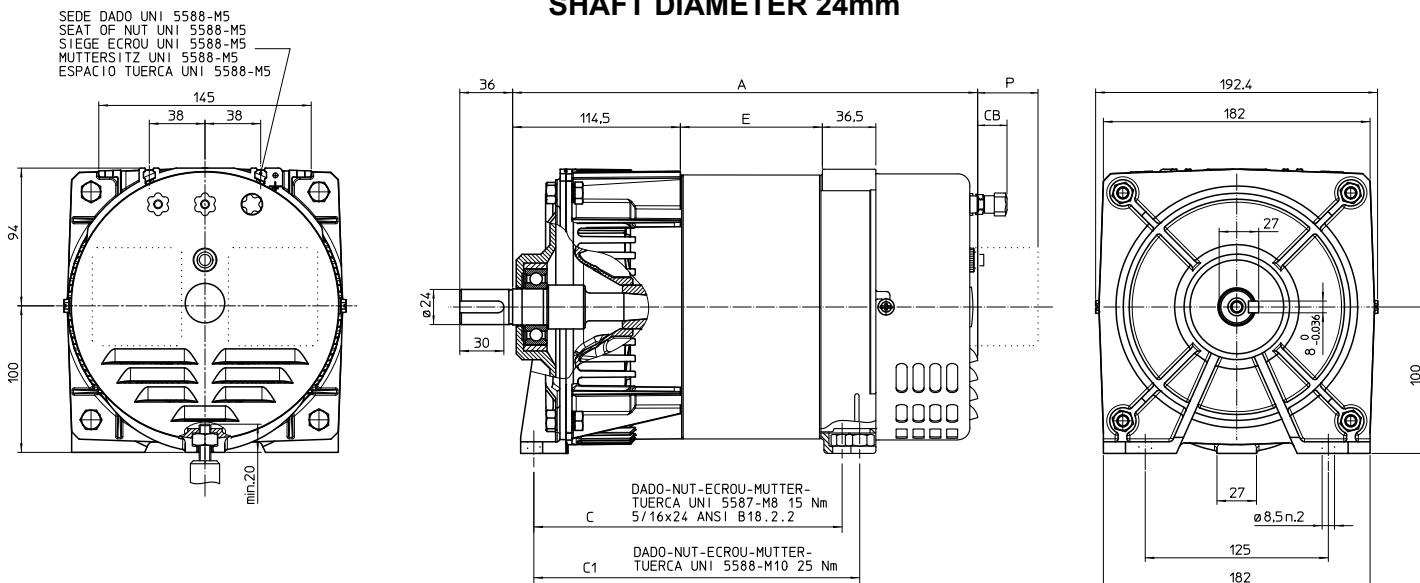

TYPE	A	B	C	C1	E	A WITH SHORTER END COVER WITHOUT SOCKETS
S16W-75	302	147	195	207	82	272
S16W-90	317	162	210	222	97	287
S16W-105	332	177	225	237	112	302
S16W-130	357	202	250	262	137	327
S16W-150	377	222	270	282	157	347

SOCKETS TYPE	P
AMERICAN	0
FRENCH	6
SCHUKO	9
CEE	46,5

WITH BATTERY CHARGING OPTIONAL
CB
20