

**AL3-A**

Zanardi alternatori s.r.l. Via Dei Laghi 48/B 36077 Altavilla Vicentina Vicenza- Italy
 tel.+39 0444 370799 fax.+39 0444370330 e-mail: info@zanardialternatori.it
 web site: www.zanardialternatori.it

**2-4 POLE
 BRUSHLESS
 LOW-VOLTAGE**

24 VDC 3Ph. CHARACTERISTICS

Tipo type typ	R.P.M.	Voltage (Volt)	Current (Amp.)	Power (kW)	Duty Cycle	P.F.	Efficiency		fattore di utilizzo / Duty cycle	regulation	Ripple* (%)
							3/4	4/4			
AL3-A 1S/4V24	1800	24	250	6	S1	1	82	81,4	S1	AVR	<3
AL3-A 2S/4V24	1800	24	333	8	S1	1	84,1	83,1	S1	AVR	<3
AL3-A 1L/4V24	1800	24	500	12	S1	1	84,8	83,9	S1	AVR	<3
AL3-A 1S/2V24	3600	24	250	6	S1	1	79,8	78,1	S1	AVR	<3
AL3-A 2S/2V24	3600	24	375	9	S1	1	81,2	80,5	S1	AVR	<3
AL3-A 3S/2V24	3600	24	500	12	S1	1	82,2	81,3	S1	AVR	<3

48 VDC 3Ph. CHARACTERISTICS

Tipo Type typ	R.P.M.	Voltage (Volt)	Current (Amp.)	Power (kW)	Duty Cycle	P.F.	Efficiency		fattore di utilizzo / Duty cycle	regulation	Ripple* (%)
							3/4	4/4			
AL3-A 1S/4V48	1800	48	125	6	S1	1	81,8	81,2	S1	AVR	<3
AL3-A 2S/4V48	1800	48	166	8	S1	1	83,9	82,8	S1	AVR	<3
AL3-A 1L/4V48	1800	48	250	12	S1	1	84,7	83,8	S1	AVR	<3
AL3-A 1S/2V48	3600	48	125	6	S1	1	79,5	78,6	S1	AVR	<3
AL3-A 2S/2V48	3600	48	187	9	S1	1	80,8	79,5	S1	AVR	<3
AL3-A 3S/2V48	3600	48	250	12	S1	1	82	81,2	S1	AVR	<3

Ambient 40°C

Tipo Type Typ	Weight (Kg)	J (Kgm²)	Air volume (m³/min)		Noise dB (A)			
					50Hz		60Hz	
			50Hz	60Hz	1mt.	7mt.	1mt.	7mt.
AL3-A 1S/4	67	0,0526	3,5	2,6	72	58	78	60
AL3-A 2S/4	72	0,0596						
AL3-A 1L/4	90	0,0727	3,3	4				
AL3-A 1S/2	63	0,0398	6,3	7,8	85	70	89	73
AL3-A 2S/2	71	0,0459	6,2					
AL3-A 3S/2	88	0,0518	6					
AL3-A 2L/2	98	0,0577	5,8					



ELECTRIC DIAGRAM

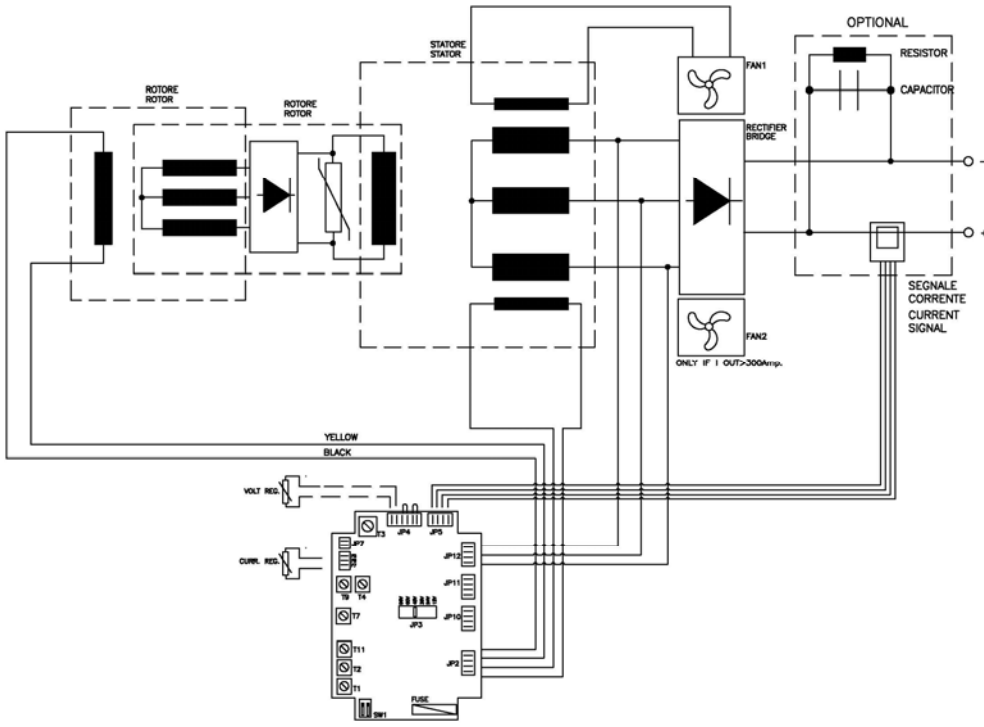

TYPICAL ELECTRICAL DATA

AL3

*= value with three phase winding and capacitor filter. (battery connected)

ELECTRICAL DATA

Type: brushless

Regulation: capacitor

Excitation: diodes in rotor

Cooling: by fan

Voltage accuracy: +/- 8%

Insulation class: H

Protection degree: IP 23

Temperature rise class: H

AL3-A

*= value with three phase winding and capacitor filter. (battery connected)

ELECTRICAL DATA

Type: brushless

Regulation: electronic RT-DC regulator

Voltage accuracy: +/- 2% (depend model alternator)

Cooling: winding: fan / rectifier: electric fan

Adjustable: from 20 to 32 vdc (24 vdc version); from 45 to 58 vdc (48 vdc version)

Under speed protection include

Exciter current protection include

0-10vdc output linear with output current (with sensor current option)

Insulation class: H

Temperature rise class: H

Protection degree: IP 21

IMPREGNATION		HEATERS	THERMAL PROTECTION			MECHANICAL PROTECTION	
STANDARD RESIN	EG 43 RESIN		PTC	BIMET. DEVICE	PT100	IP 23	IP 45
<input type="checkbox"/>	<input checked="" type="checkbox"/>	<input type="checkbox"/>	<input type="checkbox"/>	<input type="checkbox"/>	<input type="checkbox"/>	<input checked="" type="checkbox"/>	<input type="checkbox"/>

IMPREGNATION		HEATERS	THERMAL PROTECTION			FILTER	CURR. SENSOR	6 PHASE 2 POLE ONLY
STANDARD RESIN	EG 43 RESIN		PTC	BIMET. DEVICE	PT100			
<input checked="" type="checkbox"/>	<input type="checkbox"/>	<input type="checkbox"/>	<input type="checkbox"/>	<input checked="" type="checkbox"/>	<input type="checkbox"/>	<input type="checkbox"/>	<input type="checkbox"/>	<input type="checkbox"/>

● = STANDARD □ = OPTIONAL

OVERALL DIMENSIONS

B3-B14

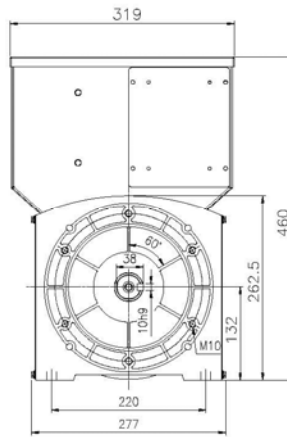
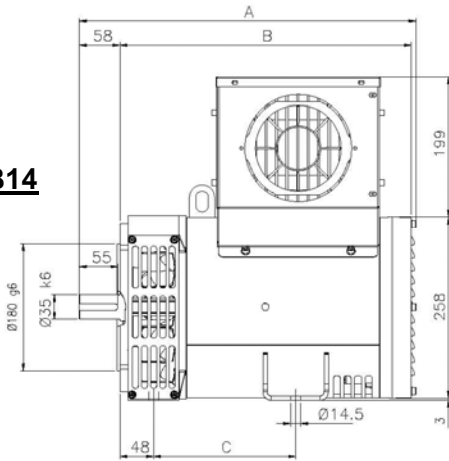

B9

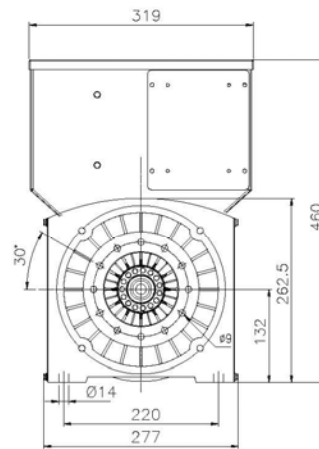
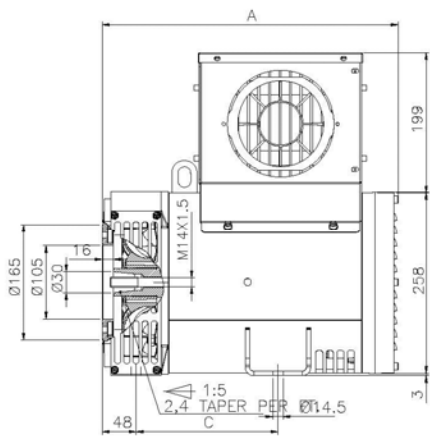

J609 b

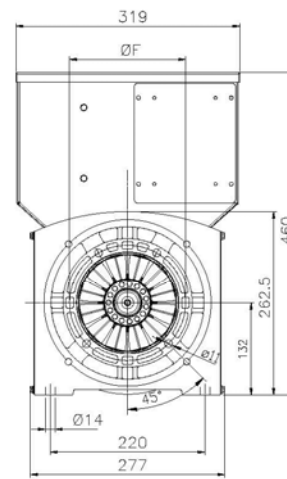
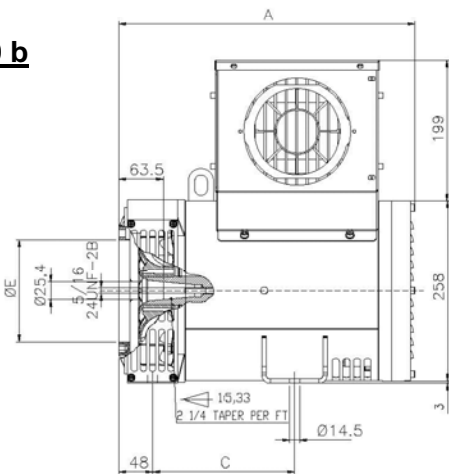

MD 35

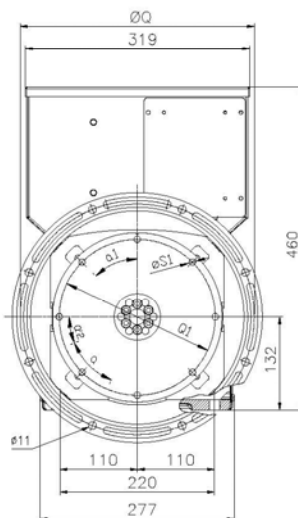
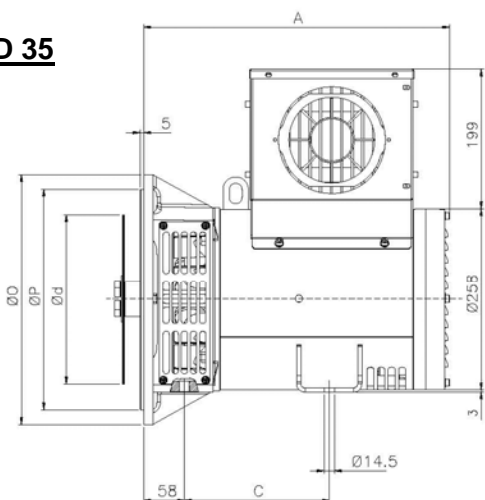

FORMA FORM	TIPO TYPE	A	B	C	E	F
B3B14	S	480	415	202	/	/
	L	552	487	272	/	/
B9	S	421	/	202	/	/
	L	493	/	272	/	/
J609b	S	421	/	202	146,1	165,1
	L	493	/	272	163,6	196,8
MD35	S	435	/	206	/	/
	L	507	/	276	/	/

FLANGIA FLANGE					
SAE	□	P	Q	Fori N° Holes N°	?/2
6	308	266,7	285,75	8	22°30'
5	356	314,3	333,4	8	22°30'
4	403	362	381	12	15°
3	451	409,6	428,6	12	15°

GIUNTO A DISCO COUPLING DISC PLATEX						
SAE	L	d	Q1	Fori N° Holes N°	S1	∠1
6 ½	30,2	215,9	200	6	9	60°
7 ½	30,2	241,3	222,25	8	9	45°
8	6,2	263,52	244,47	6	11	60°
10	53,8	314,32	295,27	8	11	45°
11 ½	39,6	352,42	333,37	8	11	45°

SPARE PARTS LIST

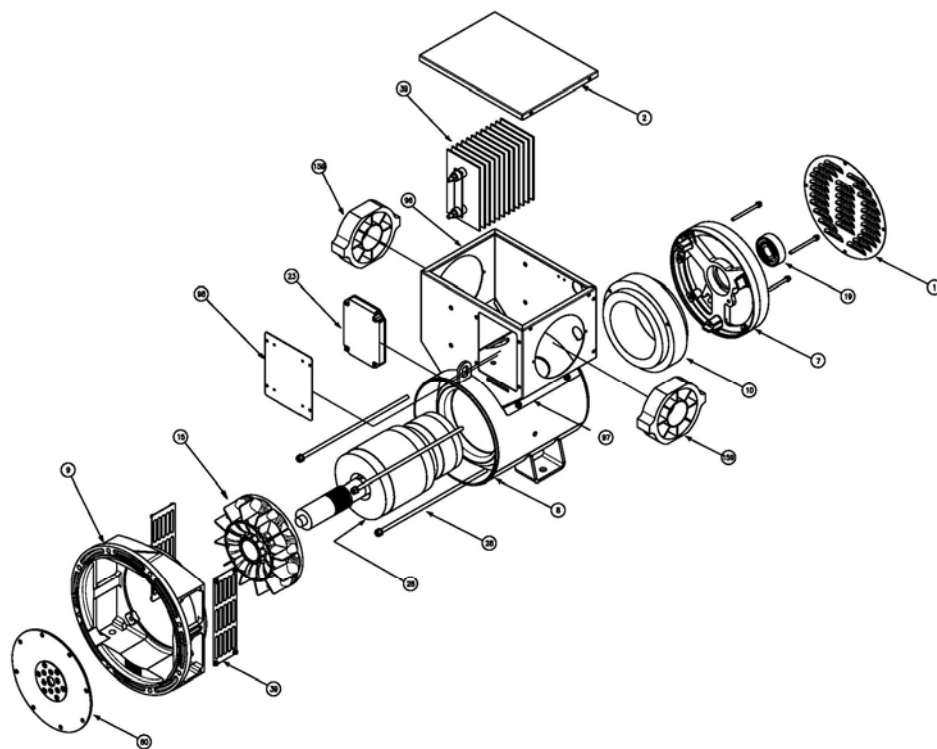

N°	DENOMINAZIONE	NAME	DESIGNATIONS	NAMEN	DENOMINACION	CODE
1	Chiusura posteriore	Rear seal	Tole de fermeture	Deckel	Cierre posterior	9LMGRPRPOST3A
2	Cuffia	Casing	couvercle	Klemmenkastendeckel	Tapa	9LMCUFSUPMR3A
7	Coperchio posteriore	Rear cover	Flasque arrière	Hinteres Gehäuse	Tapa posterior	8ALCOPOST3ATR
8	Carcassa con statore	Frame with stator	Carcasse avec stator	Gehäuse mit stator	Carcaza con estator	ON DEMAND
9	Coprechio anteriore B3-B14	B3-B14 Drive end bracket	Flasque avant	Vorderes Gehäuse	Tapa anterior B3-B14	8ALFLANPW3B14
	Coprechio anteriore B9	B9 Drive end bracket	Flasque avant	Vorderes Gehäuse	Tapa anterior B9	8ALFLANEPW330
	Coprechio anteriore J609 b	J609 b Drive end bracket	Flasque avant	Vorderes Gehäuse	Tapa anterior J609 b	8ALFLANEPW3BS
	Coprechio anteriore MD35	MD 35 Drive end bracket	Flasque avant	Vorderes Gehäuse	Tapa anterior MD 35	ON DEMAND
10	Statore eccitatrice	Exciter stator	Stator excitatrice	Erregerstator	Estator excitatriz	8STECCECO3PW3
14	Induttore rotante	Rotor	Roue polaire	Rotor	Inducido rotante	ON DEMAND
15	Venola B9	B9 fan	Ventilateur B9	Lüfterrad B9	Ventilador	9PLVNECP3F40B
	Ventola MD 35	MD35 fan	Ventilateur MD35	Lüfterrad MD35	Ventilador MD 35	9PLVNECP3F49M
17	Cuscinetto anteriore	Front bearing	Roulment avant	Vorderes Lager	Cojinete anterior	9MNCS013082RS
19	Cuscinetto posteriore	Rear bearing	Roulment arriere	Hinteres Lager	Cojinete posterior	9MNCS01305C3*
23	Regolatore elettronico	Electronic regulator	Régulateur électronique	Elektronischer regler	Regulador electrónico	8ELRGAVR1217A
28	Tirante coperchi	Cover stay bolt	Tige de flasque	Stehbolzen	Tirante de la tapa	ON DEMAND
39	Retina di protezione	Protection screen	Grille de protection	Abluftgitter	Rejilla protección B9	9LMRTPRECO3B1
60	Dischi	Disc plates	Disques	Kupplungsscheiben	Discos	ON DEMAND
96	Pannello ant.	Front panel	Panneau avant	Vorderes Blech	Panel anterior	9LMPAN2ALAN3A
97	Pannello post.	Rear panel	Panneau arriere	Hinteres Blech	Panel posterior	9LMPAN1ALAN3A
98	Pannello porta regolatore	Regulator carrying panel	Panneau support regulateur	Regler Blech	Panel portaregulador	9LMPANCOMPS3A
159	Eletto-ventola	Electric-fan	Electric-ventilateur	Elektro-Lüfterrad	Electro-ventilador	9ELVN17215038

Nella richiesta di parti di ricambio specificare il tipo e il codice dell'alternatore / When requesting spare parts always indicate the alternator's type and code / Pour toute demande de pieces detachées, prière de mentionner le type et le code de l'alternateur / Beiersatzteilbestellung bitte immer die teibenennung den typ und den code des wechselstromgenerators angeben / En cada pedido de pizas de recambio especificar siempre el tipo y el codigo del alternador.